

Numerical modelling of groundwater basins

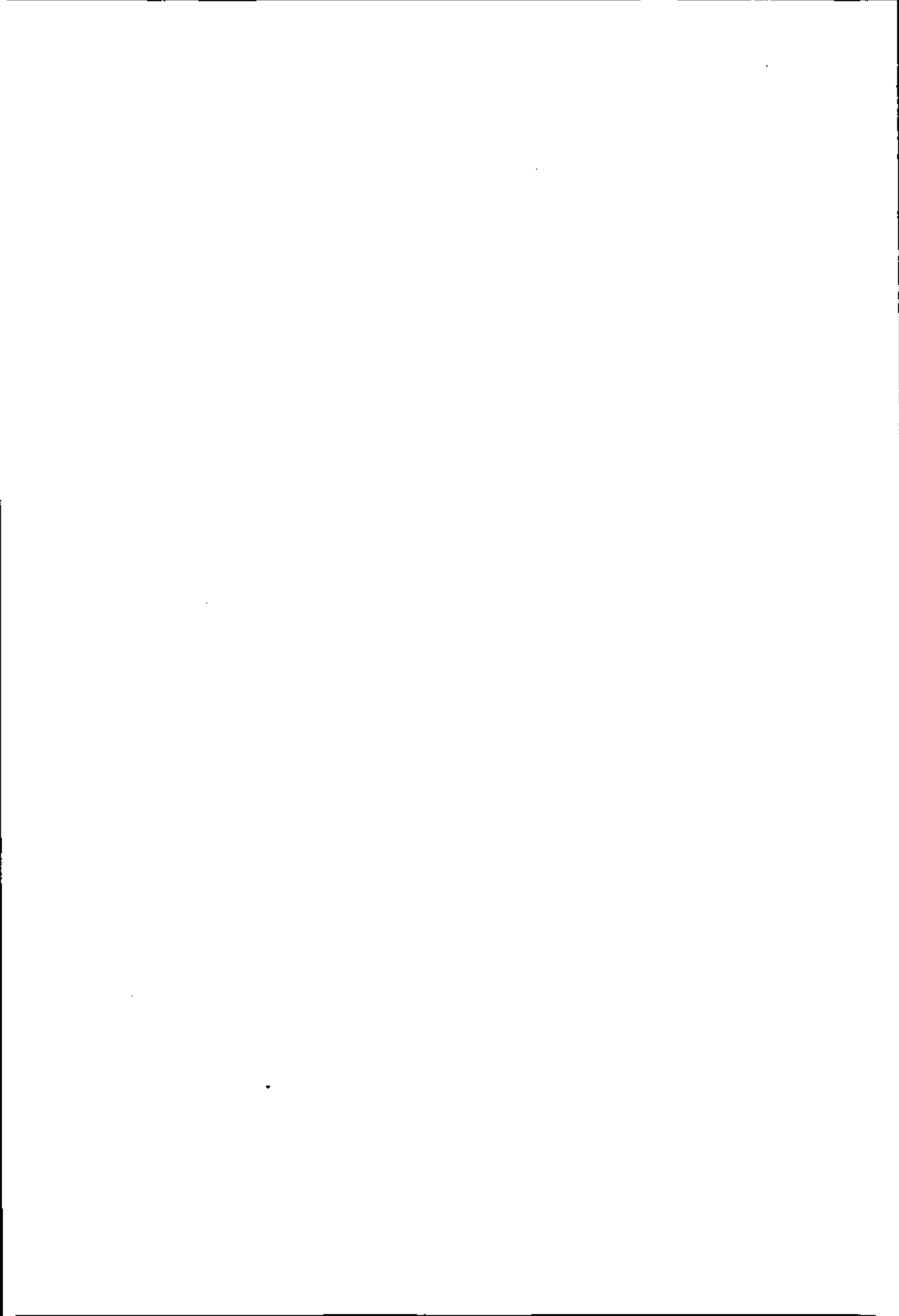

Numerical modelling of groundwater basins

A user-oriented manual

**J. Boonstra
N. A. de Ridder**

International Institute for Land Reclamation and Improvement/ILRI
P.O. Box 45, 6700 AA Wageningen, The Netherlands 1981.

First edition 1981
Second edition 1990

© International Institute for Land Reclamation and Improvement ILRI, Wageningen, The Netherlands, 1990.

This book or any part thereof must not be reproduced in any form without the written permission of ILRI.

ISBN 90 70260 69 7

Printed in The Netherlands.

CONTENTS

	PREFACE	x
1	INTRODUCTION	1
1.1	General	1
1.2	The model	3
1.3	Scope of the book	5
2	DATA REQUIRED TO DEVELOP A GROUNDWATER MODEL	7
2.1	Introduction	7
2.2	Physical framework	9
2.2.1	Topography	9
2.2.2	Geology	10
	<i>Geomorphology</i>	11
	<i>Subsurface geology</i>	13
2.2.3	Types of aquifers	16
2.2.4	Aquifer thickness and lateral extent	17
2.2.5	Aquifer boundaries	22
	<i>Zero-flow boundary</i>	22
	<i>Head-controlled boundary</i>	25
	<i>Flow-controlled boundary</i>	26
2.2.6	Lithological variations within the aquifer	30
2.2.7	Aquifer characteristics	32
	<i>Estimating KD or K from in-situ test data</i>	32
	<i>Estimating K from grain size</i>	36
	<i>Flow net method</i>	42
	<i>Other methods</i>	43
	<i>Hydraulic conductivity map</i>	45

	<i>Estimating specific yield</i>	45
	<i>Estimating storage coefficient</i>	47
2.3	Hydrological stress	48
2.3.1	Watertable elevation	49
2.3.2	Type and extent of recharge areas	52
2.3.3	Rate of recharge	55
	<i>Groundwater flow</i>	55
	<i>Rainfall-watertable relation</i>	55
	<i>Runoff hydrograph</i>	56
	<i>Lysimeters</i>	58
	<i>Tensiometers</i>	58
	<i>Isotopes</i>	58
	<i>Stream flow</i>	58
2.3.4	Type and extent of discharge areas	59
2.3.5	Rate of discharge	59
	<i>Springs</i>	59
	<i>Stream-base-flow/watertable relation</i>	60
	<i>Evapotranspiration</i>	62
	<i>Upward seepage</i>	65
	<i>Horizontal flow</i>	66
	<i>Groundwater abstraction</i>	66
2.4	Groundwater balance	67
	<i>Estimating unknown components</i>	70
	<i>Estimating aquifer characteristics</i>	71
	<i>Final remarks</i>	73
3	DESCRIPTION OF THE MODEL	75
3.1	General	75
3.2	Physical background	76
3.3	Numerical approaches	79
3.4	Design of nodal network	84
3.5	Data required for the model	90
3.5.1	Nodal coordinates	90
3.5.2	Hydraulic conductivity	91
3.5.3	Aquifer thickness	91

3.5.4.	Specific yield and storage coefficient	95
3.5.5	Hydraulic head	96
3.5.6	Net recharge	97
4	PROGRAM DETAILS	99
4.1	Package description	99
4.2	Structure of data sets	102
4.2.1	Data Set I	102
	<i>Definitions of input variables</i>	102
	<i>Sequence of cards and data formats</i>	112
4.2.2	Data Set II	113
	<i>Definitions of input variables</i>	114
	<i>Sequence of cards and data formats</i>	116
4.2.3	Data Set III	117
	<i>Definitions of input variables</i>	117
	<i>Sequence of cards and data formats</i>	118
	<i>Definitions of output variables</i>	118
4.2.4	Data Set IV	121
	<i>Definitions of input variables</i>	122
	<i>Sequence of cards and data formats</i>	125
4.2.5	Data Set V	125
	<i>Definitions of input variables</i>	127
	<i>Sequence of cards and data formats</i>	127
4.3	Program adaptations	128
4.3.1	Adaptations to nodal network	128
4.3.2	Adaptations to computer systems	129
4.4	Some remarks for the system manager	131
5	SAMPLE RUN	135
5.1	Introduction	135
5.2	Description of the area	135
5.3	Data preparation	138
5.3.1	Parameters for the configuration of the network	138
5.3.2	Parameters of dimensions	139
5.3.3	Parameters of time discretization	140

5.3.4	Geohydrological parameters	140
5.3.5	Topographical parameters	142
5.3.6	Initial conditions	144
5.3.7	Boundary conditions	145
5.3.8	Historical watertable elevations	147
5.3.9	Groundwater balance	148
5.3.10	Other input data	148
5.4	Transfer of data	149
5.4.1	Preparation of Data Set I	149
5.4.2	Sequence of cards and data formats in Data Set I	152
5.4.3	Preparation of Data Set II	154
5.4.4	Sequence of cards and data formats in Data Set II	159
5.4.5	Preparation of Data Set III	161
5.4.6	Preparation of Data Set IV	161
6	CALIBRATION AND PRODUCTION RUNS	169
6.1	Calibration	169
6.1.1	General	169
6.1.2	Sources of error	171
	<i>Transmissivity</i>	172
	<i>Storage coefficient (or specified yield)</i>	172
	<i>Watertable elevation</i>	174
	<i>Percolation or abstraction</i>	175
6.1.3	Calibration procedure	176
6.2	Production runs	181
6.2.1	General	181
6.2.2	Data requirements	182
6.2.3	Sensitivity analysis	185
6.2.4	Network modification	186
APPENDIX 1	LISTING OF SOURCE PROGRAMS	187
APPENDIX 2	DATA FORMATS	209
APPENDIX 3	SEPARATION OF THE COMPONENTS OF THE NET RECHARGE	213

REFERENCES	217
SUBJECT INDEX	221
AUTHOR INDEX	225

PREFACE

With the advance of high-speed electronic computers, numerical models are being extensively used in analysing groundwater flow problems. Yet, confusion and misunderstanding still surround their application, even though such famous old-timers as Laplace and Newton were long ago applying numerical techniques to solve physical problems.

It cannot be denied that the results of some groundwater models have proved erroneous. This has led a number of hydrologists to overreact by concluding that groundwater modelling is worthless. At the other extreme we find the admirers of models, who unconditionally accept any computer result, even if it makes no hydrological sense. Between these two extremes there is the silent majority of hydrologists, who regard computerized groundwater modelling as an esoteric technique practised only by the happy few of initiates. It is particularly for this category of colleagues, and for students as well, that we have written this book. For those who belong in the two extreme categories, we hope that we can alleviate at least some of their misconceptions about groundwater models. And yet, one should not expect miracles from models, which are, and cannot be anything more than, simplifications of the complex conditions that we face in nature.

A wealth of papers have been written on numerical groundwater models; but if a geologist or hydrologist wants to apply the technique described in them, he scarcely knows how to proceed. If a manual is available, it will very likely describe how the model was developed but not how it should be used. Groundwater modelling is a multidisciplinary science, involving

geology, climatology, surface water hydrology, groundwater hydraulics, and computer language. A person familiar with all these disciplines is a rare person indeed. Nevertheless, we hope to guide a potential user through the maze of these disciplines and show him how to develop and calibrate a model and put it into operational use.

As a service to our readers, we are offering a copy of the computer programs in the form of a complete set of punched computer cards. These can be ordered from ILRI; the only costs involved are those of copying the programs and of mailing the cards. Also available is a test example, which allows the user to check whether he is handling the model correctly.

We are grateful for comments and suggestions received from colleagues and students who read the manuscript carefully and drew our attention to shortcomings and unclear sentences. In particular, we wish to thank Mr. I.M. Goodwill, Department of Civil Engineering, University of Leeds, Mr. D. MacTavish, Binnie and Partners, London, Mr. D.N. Lerner, London, Dr. J.J. de Vries, Free University of Amsterdam, Dr. G.P. Kruseman, International Agricultural Centre, Wageningen, Mr. W. Boehmer, Euroconsult, Arnhem, and Mr. A. Bosscher, International Institute for Earth Sciences, Enschede, for their most valuable comments.

Thanks are also due to Ms. M. Wiersma-Roche for editing and correcting our English, Ms. M. Beerens for typing the manuscript, and Mr. J. van Dijk for the drafting.

In presenting this book, we hope to have made a contribution to a better understanding of what a groundwater model is, what it can do, and, what is probably more important, what it cannot do. If we have aided in eliminating some of the confusion surrounding groundwater modelling, we have achieved our goal.

J. Boonstra
N.A. de Ridder

INTRODUCTION

1.1 General

The groundwater in a basin is not at rest but is in a state of continuous movement. Its volume is increasing by the downward percolation of rain and surface water, causing the watertable to rise. At the same time its volume is decreasing by evapotranspiration, by discharge to springs, and by outflow into streams and other natural drainage channels, causing the watertable to fall. When considered over a long period, the average recharge equals the average discharge and a state of hydrological equilibrium exists. The watertable is virtually stationary, with mere seasonal fluctuations around the average level.

If man interferes in this hydrological equilibrium, he may create undesirable side-effects. The abstraction of groundwater from wells, for example, will lower the watertable, allow the natural recharge to increase, and cause the natural discharge to decrease. If the abstraction is kept within certain limits, the increase in recharge and the decrease in discharge will balance the abstraction and a new hydrological equilibrium will be established. The watertable will again be almost stationary, although at a deeper level than before. If this level is too deep, it may affect agriculture and the eco-systems in the area. Excessive abstraction from wells can cause a continuous decline in the watertable, which means that the groundwater reserves are being depleted.

Man's interference can also cause watertables to rise. When irrigation is introduced into an area, for example, millions of cubic metres of water are transported to and distributed over areas which before only received scanty rain. Some of this water seeps to the underground from the canals and more of it percolates downward from the irrigated fields. These water losses cause the watertable to rise, because the recharge exceeds the natural discharge. This may eventually lead to waterlogging - in arid areas usually accompanied by salinization of the soil - which can render once fertile land into waste land, to the detriment of local farmers and even of national economies.

Groundwater and the laws that govern its flow have been a subject of interest to many scientists, with most of their research focussed on finding solutions to specific problems of groundwater flow. For ideal situations, solutions are obtained by combining Darcy's equation and the equation of continuity. The resulting differential equation, or set of differential equations, describes the hydraulic relations within an aquifer. To solve the equation(s), the aquifer's geometry, hydraulic characteristics, and initial and boundary conditions must be known. Only if the equations, characteristics, and conditions are simple can an exact analytical solution be obtained.

Unfortunately, there are many groundwater flow problems for which analytical solutions are difficult, if not impossible, to obtain. The reason is that these problems are complex, possessing non-linear features that cannot be included in analytical solutions. Such non-linear features involve variations in an aquifer's hydraulic conductivity, boundary conditions that change with time, and other long-term time-dependent effects. Sometimes analytical solutions are yet applied to such problems by oversimplifying the complex hydrogeological situation. Since the assumptions underlying the solution are untrue, it is obvious that the results will be inaccurate or even totally erroneous.

Owing to the difficulties of obtaining analytical solutions to complex groundwater flow problems, there has long been a need for techniques that enable meaningful solutions to be found. Such techniques exist nowadays in the form of mathematical or numerical modelling. Although the technique of

solving groundwater flow problems numerically is not new, it is only since the development of high-speed computers that the technique has become widely used.

Of the great variety of numerical techniques, all of them have in common that an approximate solution is obtained by replacing the basic differential equations that describe the flow system by another set of equations that can easily be solved by a digital computer. The model we present in this book is based on one of these techniques; the finite difference method.

The finite difference method of approximating the solution of differential equations is fairly simple. It replaces the partial differential equations for two-dimensional flow in an aquifer by an equivalent system of finite-difference equations which are solved by the computer. Unlike the analytical method, which gives a solution to a continuous boundary-value problem, the finite difference method provides a set of watertable elevations at a finite number of points in the aquifer.

1.2 The model

The model we present in this book can be used to predict the impact of man's interference in the hydrological equilibrium of a groundwater basin. It can simulate the effects of new irrigation schemes, new patterns and rates of groundwater abstraction, and artificial recharge of the basin, and can do so for any desired length of time.

The model can be applied to an unconfined aquifer, a semi-confined aquifer, or a confined aquifer, or to any combination of these, provided that one type passes laterally into the other. The model cannot be used for multi-aquifer systems, i.e. aquifers overlying one another and separated by impermeable or slightly permeable layers. Three-dimensional flow problems cannot be studied by the model.

The model allows wide variations in such aquifer parameters as hydraulic conductivity and storage coefficient to be taken into account and included in the model. Transient (unsteady) flow problems can also be studied,

provided that the flow is laminar and Darcy's law thus applies. Turbulent flow, as may occur in karstified limestones, cannot be studied.

The model is devised for saturated flow only. This means that the processes of infiltration, percolation, and evaporation, which occur in the unsaturated zone of unconfined aquifers and the covering layer of semi-confined aquifers, cannot be simulated. They must be calculated by hand and their algebraic sum prescribed to the model.

The method used by the model to solve the finite-difference equations is essentially that of Gauss-Seidel, which is unconditionally stable. It is an iterative calculation process that is continued as long as is necessary to obtain watertable elevations that are sufficiently accurate. Apart from the advantage of avoiding stability problems, this method requires little computer memory.

As an alternative to the iteration method, we have included in the model the Gauss-Jordan elimination method, which is a modification of the Gaussian elimination method. This method requires more computer memory than the iteration method, but the solution is exact within the accuracy of the computer used.

The model also contains a plot program, by which the computer plots out the calculated watertable elevations at the various points of the flow region at the end of a prescribed time. This allows a visual evaluation of the watertable behaviour for any period of time.

Although our model has great flexibility, it cannot handle all specific hydrogeological conditions that may be encountered in practice. Enlarging the applicability of the model to cover such conditions as, for example, multi-aquifer systems or delayed yield aquifers would mean that the user must make certain adjustments in the computer programs. He can only do so, however, if he is experienced in computer programming. But, as we have written this book with the basic idea that our readers need have no previous experience with computers or computer programming, we have omitted any instructions for adjustments of this kind. We admit that this can be a disadvantage for a more experienced user.

1.3 Scope of the book

The primary aim of this book is to provide a practical guide for those involved in groundwater basin modelling, whether their training be in geology, hydrogeology, engineering, physics, or mathematics. It was not our intention to reproduce text-book material from any of these sciences but, where we deemed it useful, we have summarized certain concepts, calculation methods, or even field techniques, assuming that this would enhance the practical value of the book.

Before a numerical model of a groundwater basin can be developed, a conceptual model of the basin is required. This means that thorough hydrogeological investigations must be conducted. If the conceptual model that emerges from these investigations reveals the presence of an unconfined aquifer, a confined aquifer, a semi-confined aquifer, or any lateral combination of these, the numerical model can be developed.

Chapter 2 describes in some detail the hydrogeological studies required for the conceptual model, and also contains all the items to be studied and quantified for the numerical model. This quantification of geological and hydrological data is usually done in the form of maps. After reading Chapter 2, the user will be able to answer the question: what kind of maps must be prepared?

Chapter 3 covers the features and restrictions of the model, its physical background, and the numerical methods that are used to solve the finite-difference equations. It also explains how to divide an aquifer into smaller units and thus develop an appropriate finite-difference network. This network will depend on the hydrogeological conditions, the accuracy required in the predicted watertable elevations, and the experience of the user in modelling aquifers. The chapter concludes with a description of what data must be prepared and how this is done.

Chapter 4 explains the use of the computer program, which has been decomposed into four parts so that it can be run even on a small computer with limited core memory. The chapter also contains the structure of the various data sets required, definitions of the input variables and other symbols used, and the adaptations to be made to run the model on the computer

system available to the user. A hypothetical example of part of a graben valley is used to illustrate the process of transferring geological and hydrological data from maps to the finite-difference network, from the network to tables, and from the tables to computer cards. In a step-by-step procedure, Chapter 5 describes this process.

Any model must be calibrated to ensure that the predicted watertable elevations are sufficiently accurate. This is done by "history matching", which means that a set of computed watertables is compared with a set of actually measured watertables. Chapter 6 describes the calibration process and explains the sources of errors and how they can be detected and corrected. It concludes with instructions on how to put the calibrated model into operational use.

2 DATA REQUIRED TO DEVELOP A GROUNDWATER MODEL

2.1 Introduction

The first phase of a groundwater model study consists of collecting all existing geological and hydrological data on the groundwater basin in question. This will include information on surface and subsurface geology, watertables, precipitation, evapotranspiration, pumped abstractions, stream flows, soils, land use, vegetation, irrigation, aquifer characteristics and boundaries, and groundwater quality. If such data do not exist or are very scanty, a program of field work must first be undertaken, for no model whatsoever makes any hydrological sense if it is not based on a rational hydrogeological conception of the basin. All the old and newly-found information is then used to develop a conceptual model of the basin, with its various inflow and outflow components.

A conceptual model is based on a number of assumptions that must be verified in a later phase of the study. In an early phase, however, it should provide an answer to the important question: does the groundwater basin consist of one single aquifer (or any lateral combination of aquifers) bounded below by an impermeable base? If the answer is yes, one can then proceed to the next phase: developing the numerical model. This model is first used to synthesize the various data and then to test the assumptions made in the conceptual model.

Developing and testing the numerical model requires a set of quantitative hydrogeological data that fall into two categories:

- data that define the physical framework of the groundwater basin
- data that describe its hydrological stress

These two sets of data are then used to assess a groundwater balance of the basin. The separate items of each set are listed in Table 2.1.

Table 2.1 Data required to develop a groundwater model

Physical framework	Hydrological stress
1. Topography	1. Watertable elevation
2. Geology	2. Type and extent of recharge areas
3. Types of aquifers	3. Rate of recharge
4. Aquifer thickness and lateral extent	4. Type and extent of discharge areas
5. Aquifer boundaries	5. Rate of discharge
6. Lithological variations within the aquifer	
7. Aquifer characteristics	
Groundwater balance	

It is common practice to present the results of hydrogeological investigations in the form of maps, geological sections, and tables - a procedure that is also followed when developing the numerical model. The only difference is that for the model a specific set of maps must be prepared.

These are:

- contour maps of the aquifer's upper and lower boundaries
- maps of the aquifer characteristics
- watertable-contour maps
- maps of the aquifer's net recharge

Some of these maps cannot be prepared without first making a number of auxiliary maps. A map of the net recharge, for instance, can only be made after topographical, geological, soil, land use, cropping pattern, rainfall, and evaporation maps have been made. In this chapter it will be explained what data should be collected, what techniques can be applied to collect the data, and how these data should be processed and presented in the required form of maps.

2.2 Physical framework

2.2.1 Topography

An accurate topographical map of the groundwater basin to be modelled is a basic requirement. The scale of the map depends on the size of the basin and the aim of the study. If the aim is to make a reconnaissance study of a large basin, a scale of 1:500,000, 1:250,000, or 1:100,000 will suffice. If the basin is small or if a more detailed study of a local problem is to be made, the scale should be 1:50,000, 1:25,000, or even 1:10,000.

Whatever the size of the basin or the purpose of the study, the topographical map should show all surface water bodies, streams, and other natural or man-made water courses. It should also show contour lines of the land surface elevation.

An inventory should be made of all the wells in the area: pumped wells that withdraw substantial quantities of groundwater, observation wells that are used for measuring watertables, and wells or bores that were made for exploration of the subsurface geology. The location of the wells and bores should be indicated on the topographical map. To distinguish the different types of wells, they should be given different signs and they should be numbered. To number the wells and bore holes, some sort of square grid can be imposed on the map. The squares thus formed are given a consecutive number in horizontal direction and a consecutive letter in vertical direction. The wells in a particular square are numbered consecutively. Well 1-B-3, for example, means Well No. 3 in Square 1-B (Fig. 2.1).

The water level in observation wells is usually measured from a certain reference point, which can be the rim of the pipe or, if the wells are hand-dug, any mark or point fixed in the wall of the well. The measured water levels must be converted into water levels above (or below) a datum plane, e.g. mean sea level. To do so, a levelling survey of the wells must be made. This requires a proper system of bench marks. The levelling survey should be performed in closed circuits to ensure that the measured well elevations are correct. In large basins, one can use an error tolerance of $20\sqrt{D}$ mm, where D is the distance traversed while levelling, in kilometres; in areas with a flat watertable, greater precision may be required.

The topographical map should show the location of the bench marks with their elevations.

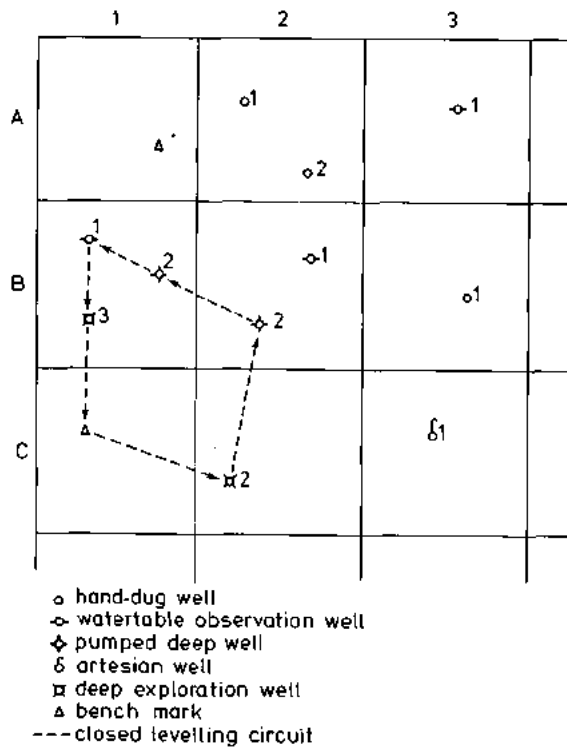

Fig. 2.1 Example of square grid for numbering wells and bore holes

2.2.2 Geology

Intensive geomorphological and geological studies of the groundwater basin will be required to delineate its geomorphological features or land forms and to evaluate the manner and degree in which they contribute to the basin's hydrology. Of special importance are the areas open to deep percolation, the subsurface areas where inflow or outflow to or from the aquifer occurs, the type of material forming the aquifer system, including its

permeable and less permeable confining formations, the location and nature of the aquifer's impermeable base, the hydraulic characteristics of the aquifer, and the location of any structures affecting groundwater movement.

Geomorphology

Land forms are the most common features encountered by anyone engaged in groundwater investigations. Properly interpreted, land forms throw light upon a groundwater basin's geological history, lithology, and hydrology.

For a proper understanding of a basin's geological history and lithological variations, one must consider the following factors:

- the nature of the source rock
- the topographical expression and relief of the source area
- the tectonic elements in the source and depositional areas
- the intensity of tectonism in each of these areas
- the transporting agents that carry the detritus to the sites of deposition
- the depositional environment
- the climate

If the source area is a strongly dissected mountain range chiefly made of weathered granite, the sediment in the basin will be different from the sediment that would be found if the source area is a mountainous area predominantly made of shale, mudstones, and easily erodable marl. Similarly, if water is the transporting agent, a different kind of sediment will be produced than if wind is the transporting agent.

Tectonism may strongly affect the nature of a groundwater basin. The source area may be uplifted while the depositional area is downwarped. The thickness of the basin fill may then be very great, ranging from several hundred metres to two or three thousand metres. Downwarping is often accompanied by faulting; this not only offsets the sediment beds in the basin but also causes abrupt changes in the thickness of the basin fill.

The past and present environment in a depositional area largely determines the lithological variations of its fill. Within a basin, several deposi-

tional environments can usually be recognized, each of which has given rise to the formation of a specific sediment type.

Groundwater basins, which are usually defined as "hydrogeological units containing one large aquifer or several connected and interrelated aquifers" (Todd 1980), may be classified on the basis of their main depositional environment. Basins may thus be fluvial, lacustrine, glacial, volcanic, or aeolian. Some basins do indeed contain one large aquifer formed in a single depositional environment. Others, especially the deeply downwarped ones, show several aquifers formed in different environments, starting for example with a marine environment, followed by a fluvial, and terminating with a glacial and/or aeolian environment.

Most groundwater basins for which a model is to be developed will have been geomorphologically and geologically explored, at least to some extent. If not, a study of the source area, or an examination of a geological map of the source area, if available, will be needed to gain an insight into the kind of detritus supplied to the basin.

Most groundwater basins, even the very flat ones, show minor relief features, originating from constructive and destructive forces acting on them. Each type of basin is characterized by specific topographical and morphological features. Typical features of a river valley basin, for example, are adjacent mountains, river terraces, and flood plain. Common features of the flood plain are: natural levees, point bars, back swamps, partly or wholly silted-up former stream channels, and oxbow lakes (Fig. 2.2). For the morphological features of other types of basins, we refer the reader to Thornbury 1969, Davis and de Wiest 1966, and Reading 1978.

For a proper understanding of the basin's hydrology, one must be able to recognize these morphological features. Generally they can be grouped into topographical highlands and topographical lowlands. The highlands are usually the recharge areas, characterized by a downward flow of water; the lowlands are the discharge areas, characterized by an upward flow of water. In Figure 2.2, for example, the recharge areas are the present and former natural levees, point bars, and river terraces; the discharge areas are the backswamps and the former, partly silted-up stream channels.

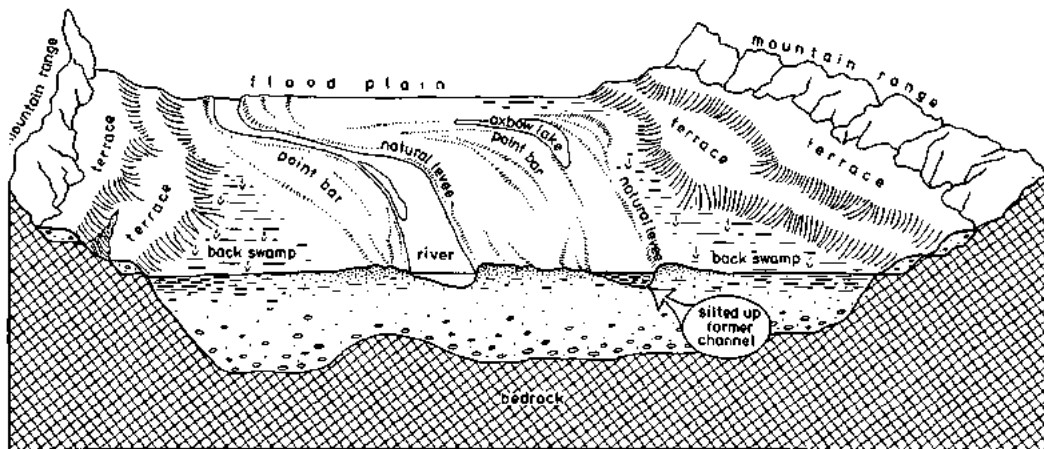

Fig. 2.2 Morphological features and sediments typical of broad river valley basins

Since the groundwater model requires quantitative data of the rate of flow in these areas, the topographical highlands and lowlands should be delineated and indicated on a map, together with the natural drainage system. These topographical features can be detected from topographical maps with contour lines of the land surface at small intervals and from aerial photographs. Field work is needed to determine the type of rock or sediment in these areas.

Subsurface geology

In any groundwater study, the geological history of the basin must be known, as the resulting geological structure largely controls the occurrence and movement of groundwater. The number and type of water-bearing formations, their depth, interconnections, hydraulic properties, and outcrop patterns are all the result of the basin's geological history.

A study of the subsurface geology is required to find out the type of materials that make up the groundwater basin, their depositional environment and age, and their structural deformation, if any. The depositional environment, being the complex of physical, chemical, and biological conditions

under which a sediment accumulates, largely determines the properties of sediments. Each environment tends to develop its own sediments. In many groundwater basins, especially the deep ones, one finds systematic transitions from one environment to another. A complicating factor is that considerable variations can occur within a single environment; for example, grain size in fluvial or glacial environments can vary widely. Conversely, two different environments can produce the same kind of sediment.

To unravel the sedimentary environment of a groundwater basin, one begins by examining well-driller's logs and bore samples. Characteristics that shed light on the environment in which the sediments accumulated are the texture, size and shape of the mineral particles, their degree of sorting, colour, organic-matter content, lime content, clay and gravel content, microfossils, and mineral composition.

Originally, in accumulation areas, the sediments were deposited in nearly horizontal layers. In large, deep groundwater basins the sediments have accumulated over a long span of time. During this period, clear breaks in the sedimentation may have occurred, erosion may have taken place, and tectonic events may have caused structural deformation of the original horizontal layers (Fig. 2.3).

Driller's logs can reveal key beds, also called marker beds, which possess a recognizable lithology or fossil content that differs from the beds above and below them. Typical key beds are a thin limestone bed, a coal or lignite bed, a pebble zone, an insoluble zone, and a horizon with a typical faunal assemblage. If such beds occur, they can often be traced from one well to another and are thus most useful for stratigraphic correlation.

Geophysical methods may be useful in exploring the subsurface geology, but the methods are often inexact and their results difficult to interpret. They should therefore only be regarded as supplementary to an exploratory drilling program.

Stratigraphic correlation requires that a number of cross-sections be drawn in different directions over the basin. These cross-sections show both the vertical and horizontal relationships between the various sediment bodies as well as the stratigraphic boundaries that either prevent or allow groundwater flow (Fig. 2.4). The cross-sections also show whether the

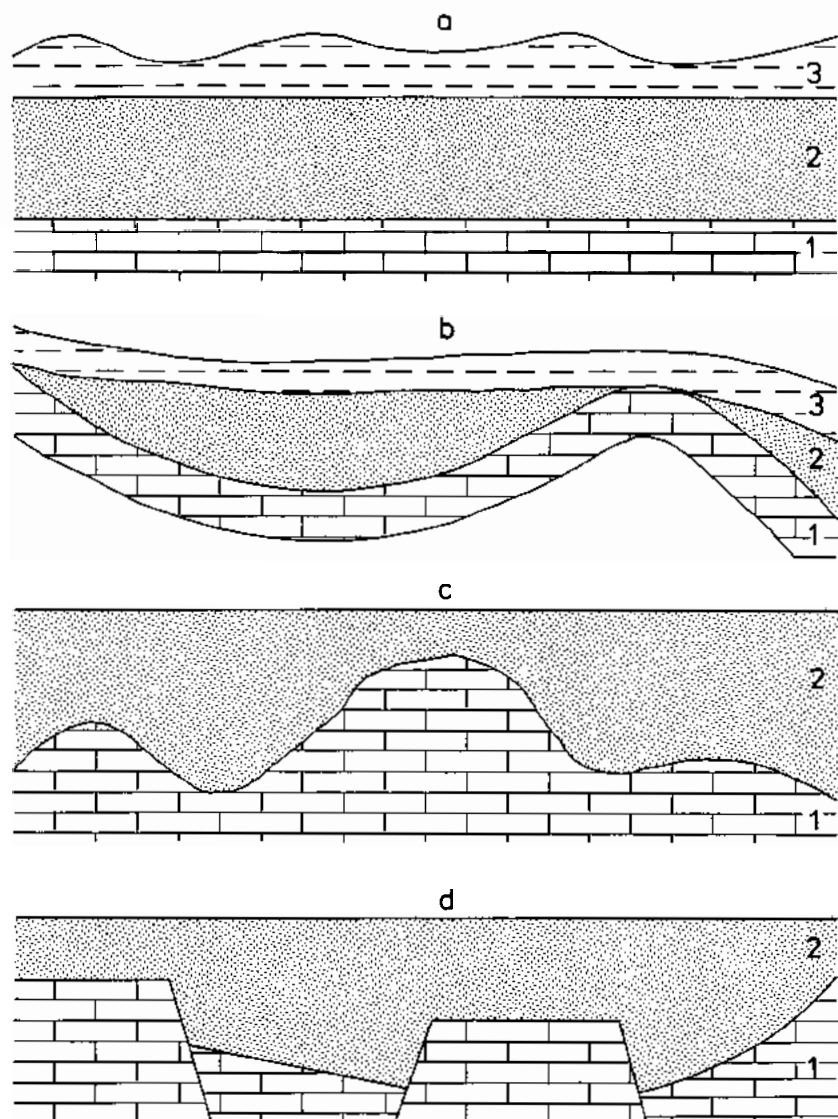

Fig. 2.3 Erosion, folding, and faulting phenomena.

a: Erratic thinning of Bed 3 indicates erosion.

b: Bed 1 has a constant thickness and was folded during or before deposition of Bed 2.

c: Bed 2 was deposited after erosion of Bed 1.

d: Bed 2 was deposited after and during faulting of Bed 1.

bedrock and all or part of the sedimentary basin fill underwent any structural deformation such as downwarping, uplifting, folding, or faulting and whether accumulation was continuous or alternated by erosion (Fig. 2.3).

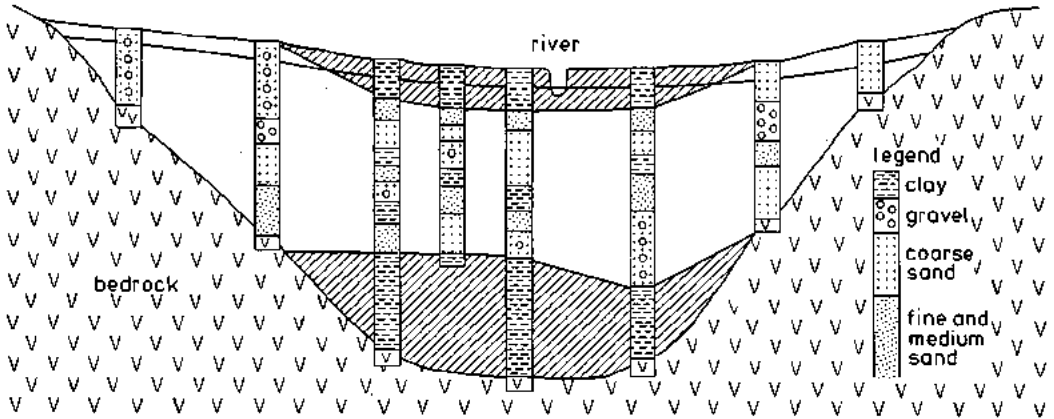

Fig. 2.4 Hypothetical cross-section through a river valley showing the vertical and horizontal relationships between sediments. In the middle of the valley, the lower body of clay forms the impermeable base; toward the valley walls bedrock forms the impermeable base

2.2.3 Types of aquifers

The geological information provided by the geologist has no meaning if it is not related to the occurrence and movement of the groundwater. This means that the geological knowledge must be translated into terms of water-bearing formations (aquifers), non-water-bearing or confining layers (impermeable layers), and slightly confining or semipermeable layers (layers with a low, but not zero hydraulic conductivity). This will often require a certain schematization of the subsurface geology. Consecutive geological formations, different in age or origin but similar in water-transmitting properties, should be grouped into a single aquifer system. Consecutive layers of sandy clay, silty clay, clay, compacted peat, silty clay loam, etc., although different in age and depositional environment, should also be grouped into a single layer of hydraulic resistance to the

flow of groundwater. Similarly, consecutive impermeable layers and hard rock, different in age and origin, should be taken together as one unit that obstructs the passage of water. The impermeable base in Figure 2.4, for example, consists partly of bedrock and partly of thick clay.

An aquifer can therefore be defined as a formation, group of formations, or part of a formation that contains sufficient saturated permeable material to yield significant quantities of water to a well or spring. The most common and most productive aquifers are unconsolidated sand and gravel. Sandstone is a cemented form of sand but can be a productive aquifer if it is jointed. Other productive aquifers are karstified limestones that contain large solution caverns and channels; as the flow in such aquifers is usually turbulent, however, our model is not applicable to them. It can only be applied to aquifers in which the flow is laminar and in which Darcy's law thus applies. The types of aquifer that can be modelled, provided that the flow in them is laminar, are the following:

- unconfined (or watertable) aquifer
- confined (or artesian) aquifer
- semi-confined (or leaky) aquifer

Figure 2.5 shows these aquifer types with their watertable positions and the symbols denoting their hydraulic characteristics. In nature, one can find different combinations of aquifers, e.g. an unconfined aquifer (Type A) overlying a confined aquifer (Type B) or a semi-confined aquifer (Type C). When several aquifers occur, separated by impermeable or slightly permeable layers, we speak of a multi-aquifer system. Our model is programmed for only one single aquifer, i.e. Type A, B, or C, or any lateral transition from one type to another.

2.2.4 Aquifer thickness and lateral extent

For a variety of reasons, the lateral extent and the thickness and depth of an aquifer may vary from one place to another. In some basins, as in those of a lacustrine environment, sandy aquifers formed where rivers entered the lake will show a distal fining of sediment away from the river mouth in a way similar to that in some marine deltas (Fig. 2.6). In fluvial basins the

reverse may be found: thick sandy aquifers may thin toward the rim of the basin. Some basins show structural deformation due to downwarping and faulting.

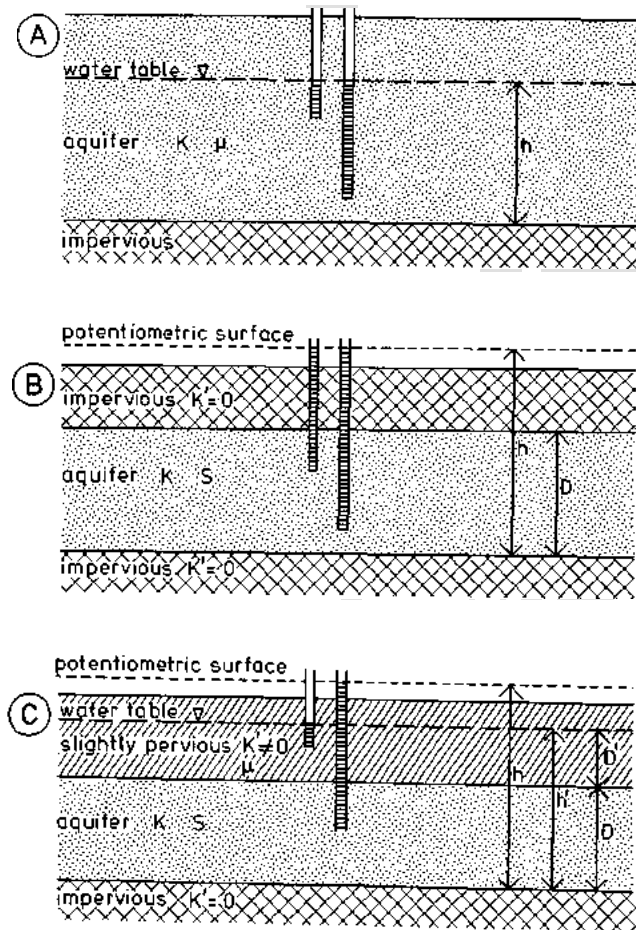

Fig. 2.5 Different aquifer types.

- A: unconfined,
- B: confined,
- C: semi-confined.

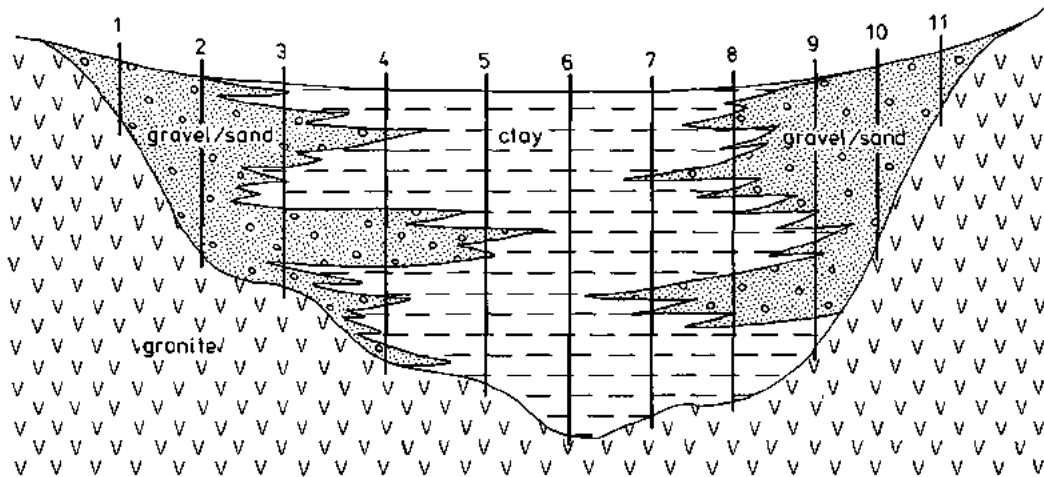

Fig. 2.6 Lithologic section through a former lake. Deltaic sand and gravel at the rim of the basin; lake clay and marl in the centre. Bore holes 1, 2, 10, and 11 contain 100 per cent sand; bore hole 6 contains 100 per cent clay; the other bore holes have differing percentages of sand and clay

The lateral extent of the aquifer, as found from well and bore logs, and geophysical data should be indicated on a map. From the same data sources, an isopach (thickness) map of the aquifer can be made. An isopach map requires two horizons, one at the top of the aquifer and one at the bottom. If the aquifer is unconfined, the two horizons are the impermeable base and the land surface. The net thickness of the aquifer can be calculated from the elevations of the two horizons; local clay lenses within the aquifer, if any, are subtracted from the total thickness. The results at each control point are plotted on a map and lines of equal thickness are drawn (Fig. 2.7).

Besides an isopach map of the aquifer, the numerical model requires a structural map of the aquifer's impermeable base. Such a map shows the configuration and elevation of the surface of that base. To construct it, one uses the logs of all wells and bore holes that struck the impermeable base. If the elevation of the land surface at these wells and bore holes is not known from a previous levelling survey (Section 2.1 of this Chapter),

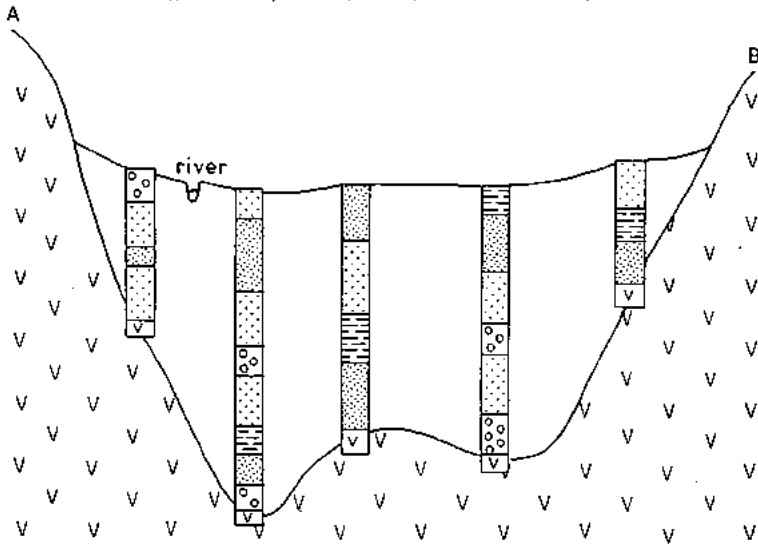
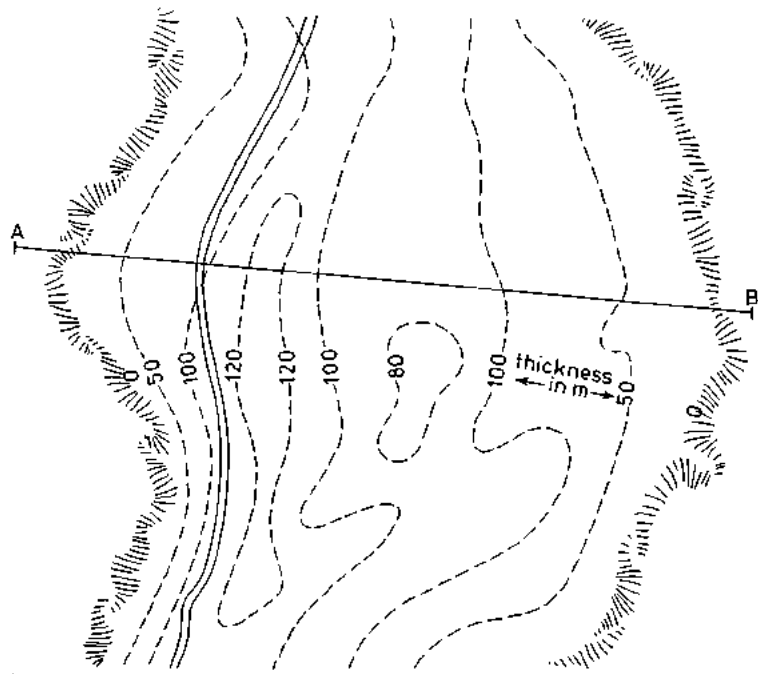

Fig. 2.7 Example of an isopach map showing the net thickness of a river-basin aquifer. The lower figure shows a cross-section of the valley

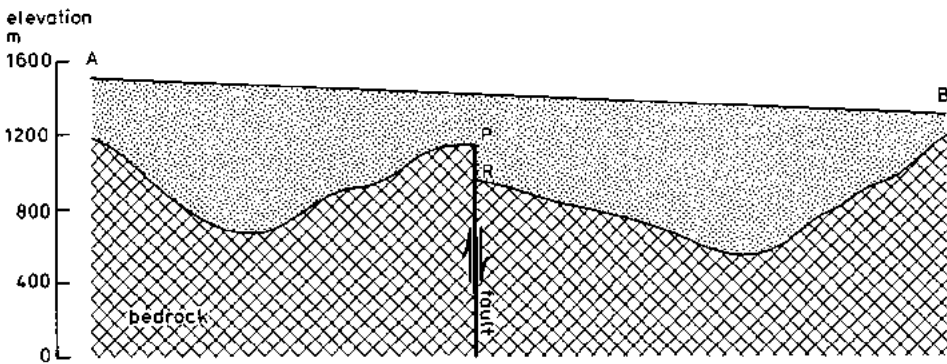
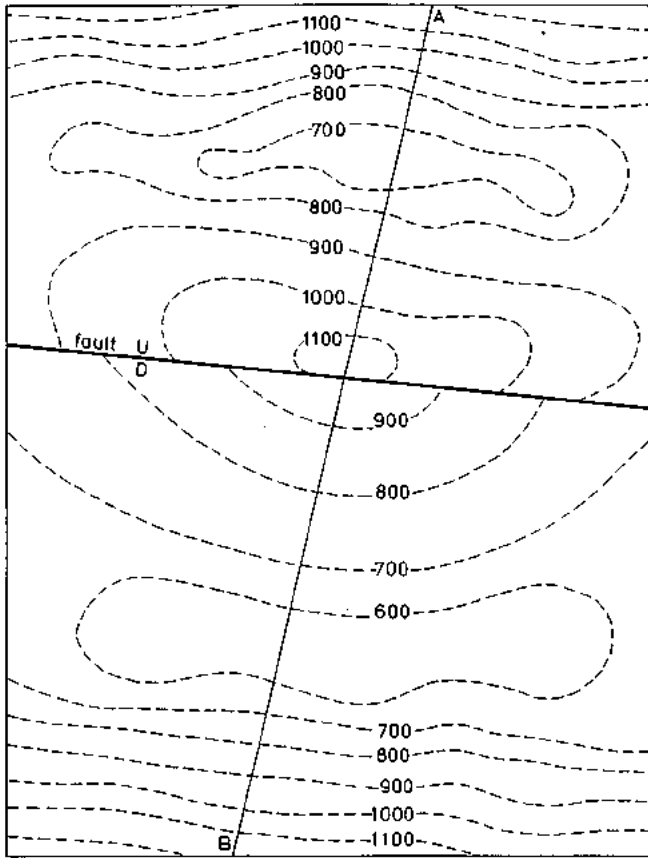

Fig. 2.8 Structural map of the impermeable base of an aquifer. A vertical dip-slip fault crosses the basin. PR = stratigraphic throw: $1100 - 900 = 200$ m

it can be estimated by interpolation from a topographical map with contour lines of the land surface. For each control point, the depth to the impermeable base indicated in the well or bore hole log is subtracted from the surface elevation. The elevation at each control point thus found is plotted on a map and contour lines are drawn (Fig. 2.8). For further details, see Chap. 2 Sect. 2.5 and Chap. 3 Sect. 5.3.

2.2.5 Aquifer boundaries

The conditions at the boundaries of the aquifer must be properly defined. Different types of boundaries exist, which may or may not be a function of time. They are:

- zero-flow boundaries
- head-controlled boundaries
- flow-controlled boundaries

To this can be added the free-surface boundary, but as this is the boundary to be determined by the model, it will not be discussed here.

Zero-flow boundary

A zero-flow boundary is a boundary through which no flow occurs. Examples of zero-flow boundaries are thick tight compacted clay layers, unweathered massive rock, a fault that isolates the aquifer from other permeable strata, or a groundwater divide. In practice, zero-flow boundaries can be defined as those places where flows are insignificant compared with the flows in the main aquifers.

Zero-flow boundaries can be differentiated into internal and external boundaries. A local outcrop of massive rock inside an alluvial basin and an aquifer's impermeable base are internal zero-flow boundaries. Impermeable materials occurring along the outer limits of an aquifer are called external zero-flow boundaries.

Many groundwater basins are erosion valleys, (partly) filled with sediments (Figs. 2.4 and 2.7); others are bowl-shaped structural basins formed by downwarping (Fig. 2.3b) or grabens formed by faulting (Fig. 2.9).

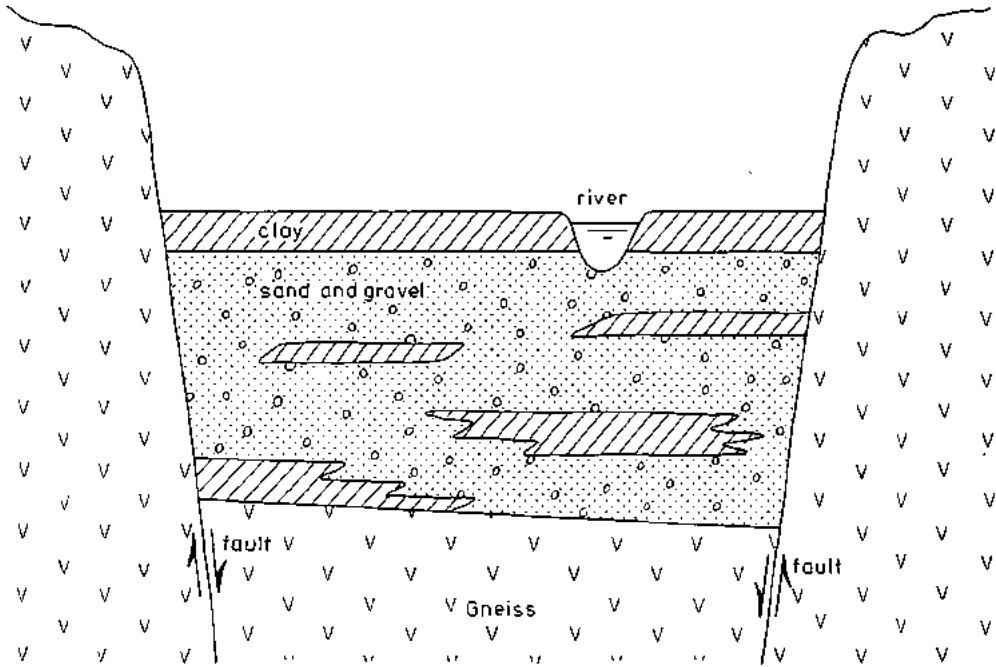

Fig. 2.9 Tectonic graben valley. The fault planes are external geologic boundaries through which no lateral flow of groundwater occurs. The slightly dipping surface of the downfaulted bedrock underlying the body of gravel, sand, and clay is an impermeable internal geologic boundary

As Figure 2.9 shows, the sand and gravel aquifer terminates abruptly against the impermeable face of the raised blocks. Such a rock wall prevents any horizontal flow to or from the aquifer and thus represents an external zero-flow boundary.

It should be noted that this is only true for massive unweathered rock. When weathered or heavily fractured, the rock may transmit appreciable quantities of groundwater. In many instances, the upper 10 to 30 m of

granitic bedrock underlying alluvial sediments is weathered, and thus acts as an aquifer. Major faults, as shown in Figure 2.9, are often the site of springs that yield warm, highly mineralized groundwater from great depths. Although such a fault does not allow the horizontal passage of groundwater, it does allow the vertical passage. At places where such deep sited springs occur, the fault must (locally) be treated as a flow-controlled boundary (see below).

The model of the basin requires that external zero-flow boundaries be delineated and indicated on a map. It also requires that the configuration and absolute elevation of the impermeable base, which is an internal zero-flow boundary, be determined. This is not always an easy task. In some groundwater basins the impermeable base lies at relatively shallow depth and its surface is flat, nearly horizontal, or slightly dipping. In other basins, however, it occurs at such great depths that it is not reached by ordinary bore holes, and its surface may be uneven because of erosion or structural deformation. In some parts of the basin the impermeable base may consist of massive rock, whereas in others it is a thick tight clay layer of much younger geological age. Major structural basins are very deep, say 2000 to 3000 m, and are filled with alternating layers of sand and clay. The question then arises: What and where is the impermeable base? In some instances the lower section of the basin-fill is predominantly clay which is so compacted by the thick overburden that it can be regarded as the impermeable base. In other instances one must resort to a fictitious depth for the impermeable base. As a first approximation one can take one-fourth to one-eighth of the average distance between the major streams draining the basin and neglect the flow below this depth. If such streams do not occur, one can estimate the thickness of the aquifer by using Hantush's method of analyzing aquifer-test data obtained from partially penetrating wells (see Kruseman and de Ridder 1970).

Finally, a groundwater divide, by definition, is a zero-flow boundary as no flow occurs across the streamline running over the top of the divide.

In mathematical terms, the condition at a zero-flow boundary is $\partial h / \partial n = 0$, where h is the groundwater potential and n is the direction normal to the

boundary. In the groundwater model, zero flow is simulated by setting the hydraulic conductivity at the boundary equal to zero ($K = 0$).

Head-controlled boundary

A head-controlled boundary is a boundary with a known potential or hydraulic head, which may or may not be a function of time. Examples are large water bodies like lakes and oceans whose water levels are not affected by events within the groundwater basin. Other examples are water courses and irrigation canals with fixed water levels. If these water levels indeed remain unchanged with time, a steady state of flow will exist.

For most practical purposes, the water levels of lakes and some seas, e.g. the Mediterranean, can be regarded as constant, but those of other water bodies and water courses may change appreciably with time (Fig. 2.10). Examples are streams that carry heavy floodwaters in the rainy season and fall (almost) dry in the dry season, and estuaries and oceans with large tidal movements.

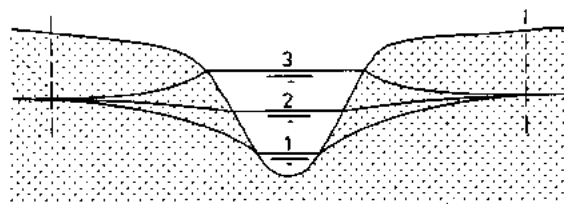

Fig. 2.10 River water level changing with time. At Levels 1 and 2 the river is gaining water, at Level 3 it is losing water

Mathematically, a head-controlled boundary that changes with time is expressed as $h = f(x,y,t)$, i.e. the head is a function of both place and time. A fixed head at the boundary is expressed as $h = f(x,y)$, i.e. the head is a function of place only.

Like zero-flow boundaries, head-controlled boundaries can be differentiated into internal and external boundaries. A stream crossing a groundwater basin and (partly) in hydraulic contact with the aquifer is an internal head-controlled boundary. For a coastal aquifer in direct contact with the ocean, the ocean is an external head-controlled boundary.

Flow-controlled boundary

A flow-controlled boundary, also called recharge boundary, is a boundary through which a certain volume of groundwater enters the aquifer per unit of time from adjacent strata whose hydraulic head and/or transmissivity are not known. The quantity of water transferred in this way usually has to be estimated from rainfall and runoff data.

The boundary itself may be one of zero-flow, for example a mountain front against which the aquifer terminates, but which is overlain by colluvium, a thin soil cover or pediment (Fig. 2.11). Runoff from rainfall may (partly) percolate into the colluvium and cross the boundary as groundwater flow into the aquifer.

A similar situation occurs where a stream flowing through mountainous areas debouches into a plain where it has formed an alluvial fan (Fig. 2.12). Fans are commonly developed along active fault scarps, so that they frequently give thick sequences of syntectonic sediments on the downthrown side of major faults. Downstream of the point of debouchment, the valley widens and deepens and is partly filled with boulders, gravel, and very coarse sand. The thickness of these coarse materials increases in downstream direction. In the proximal fan the river may split into numerous braided channels which do not allow proper flow measurements to be taken. Considerable quantities of the river flow percolate in this part of the fan and enter the mid-fan at B as underflow (Fig. 2.12). Usually this underflow can only be estimated. Its value, which enters the model as a recharge, can be checked when the model is calibrated (Chap. 6).

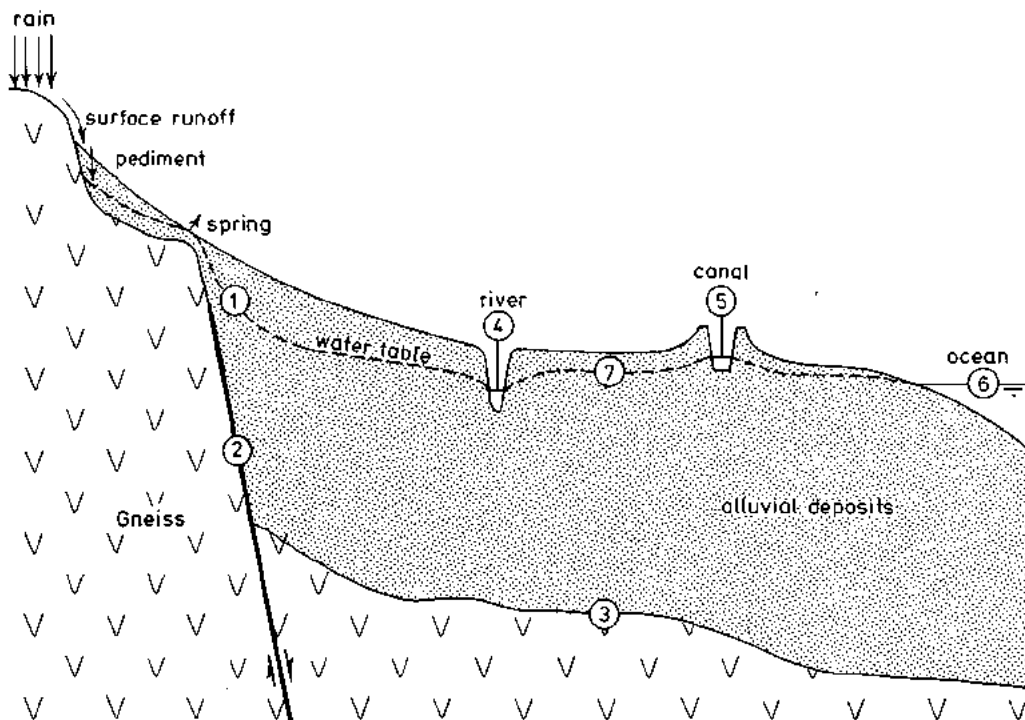

Fig. 2.11 Different types of groundwater basin boundaries.

- 1: flow-controlled boundary
- 2: external zero-flow boundary
- 3: internal zero-flow boundary
- 4 and 5: internal head-controlled boundaries
- 6: external head-controlled boundary
- 7: free surface boundary

Another example of a flow-controlled boundary is the sharp contact with another geological formation of low transmissivity. Such a contact can be a nonconformity or a fault (Fig. 2.13). The water balance of the adjacent strata and their relative transmissivity may give an indication of the likely magnitude of the flow.

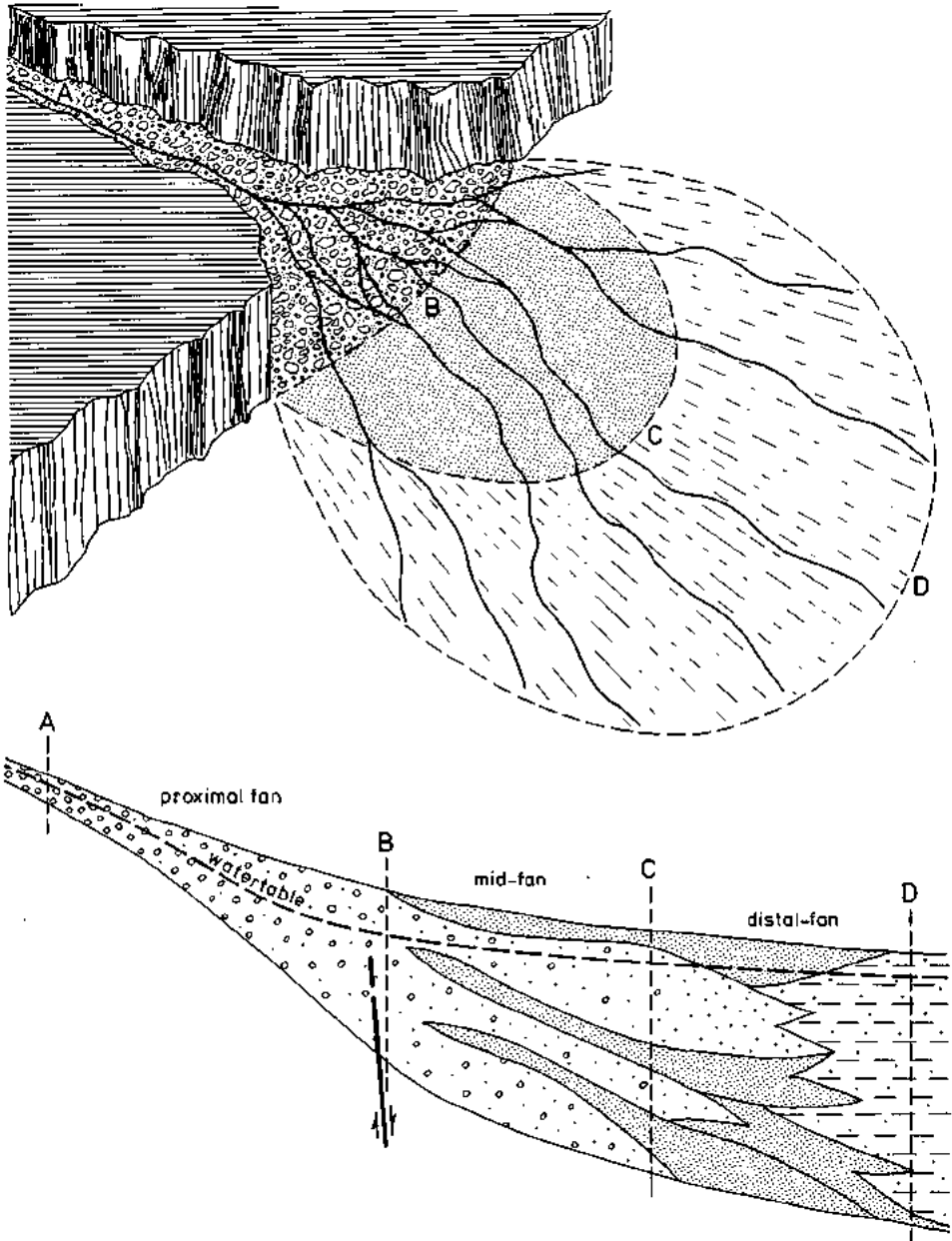

Fig. 2.12 Example of an alluvial fan and cross-section, with braided channels in the proximal part. Percolation in the proximal part enters the mid-fan at B as underflow.

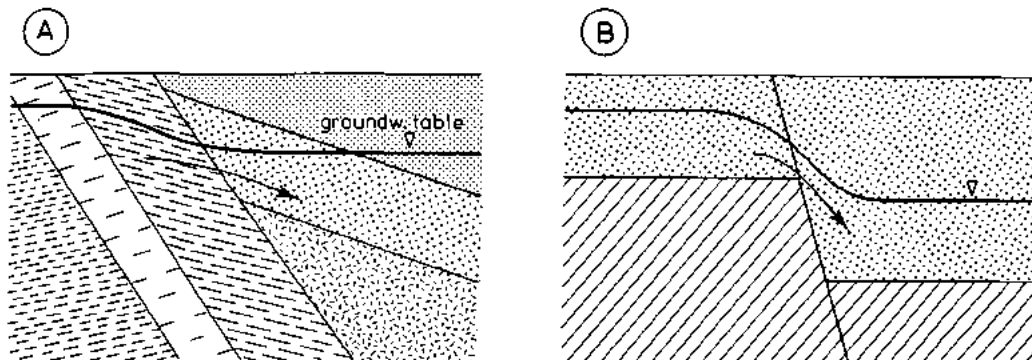

Fig. 2.13 Flow-controlled boundaries.

A: Boundary at a non-conformity

B: Boundary at a fault

Flow-controlled boundaries are simulated by setting the hydraulic conductivity at the boundary equal to zero ($K = 0$), and entering the underflow into the model as a recharge term. Mathematically, the flow is represented, for steady state, by the normal gradient $\partial h / \partial n$, taking a specified value $\partial h / \partial n = -$ (velocity normal to boundary \div permeability normal to boundary).

When modelling a groundwater basin, it is advisable to let the external boundaries of the model coincide with head-controlled and/or zero-flow boundaries. Quite often, however, a model is requested for only a portion of the basin, in which case it may not be possible to let the boundaries coincide because the nearest stream or impermeable valley wall is too far away. In such cases an arbitrary, though convenient, boundary must be chosen. Groundwater may flow across such a boundary either into or out of the aquifer, depending on the hydraulic heads on either side of the boundary. If, for example, the area beyond the arbitrary boundary is a seepage zone with a permanently high watertable, the head in this zone is fixed and the flow through the boundary is controlled by the head in the seepage zone. To calculate the flow across head-controlled boundaries, data on the hydraulic conductivity at the boundary should be available.

2.2.6 Lithological variations within the aquifer

No aquifer is lithologically uniform over its entire extent. Both lateral and vertical variations occur, which can be recognized as facies changes. In one part of the basin the aquifer may be predominantly sand and gravel, whereas in other parts fine sand or even silt and clay may predominate (Reading 1978). Since grain size has a great bearing on hydraulic conductivity and porosity, and thus on the flow and storage of groundwater, a study of facies changes forms an intrinsic part of groundwater basin modelling. Facies changes can be studied in stratigraphic units known to be contemporaneous or in groupings of strata without respect to stratigraphic boundaries or limits. The cross-sections discussed earlier can be used to determine satisfactory boundaries for facies mapping. If a stratigraphic unit with clearly defined upper and lower boundaries is selected, one can calculate the percentage of sand in the total thickness of that unit. When these percentages are plotted at each control point of a map, lines of equal sand percentage can be drawn (Fig. 2.14).

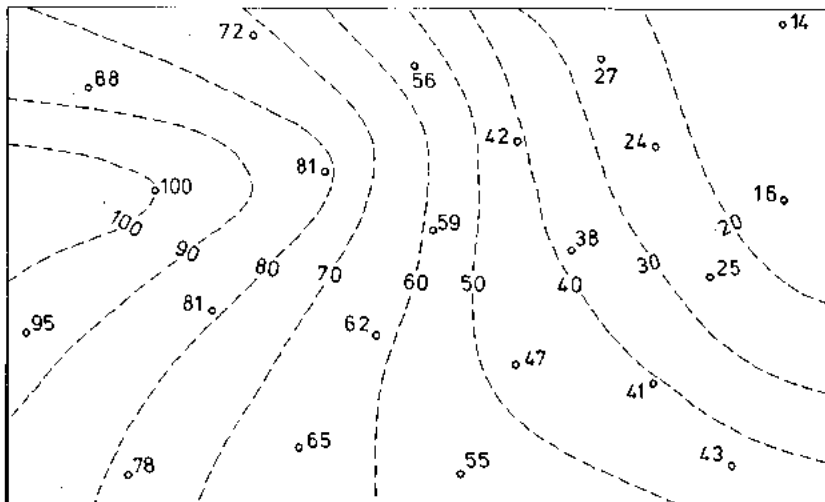

Fig. 2.14 Sand percentage map of a Quaternary formation with relatively constant thickness

Another useful type of facies map is the lithologic ratio map. It is made by calculating the ratio of sand (or sandstone) to all other sediments in a stratigraphic unit, plotting these ratios on a map, and drawing lines of equal ratio. Such a map shows the relative importance of sand (or sandstone) in the unit. The ratio values range from infinity (a section composed entirely of sand) to zero (no sand). A ratio of 1.0 means the amount of sand in the unit is equal to the sum of the other sediments. If the unit consists of only sand and clay, one can prepare a sand-clay ratio map (Fig. 2.15).

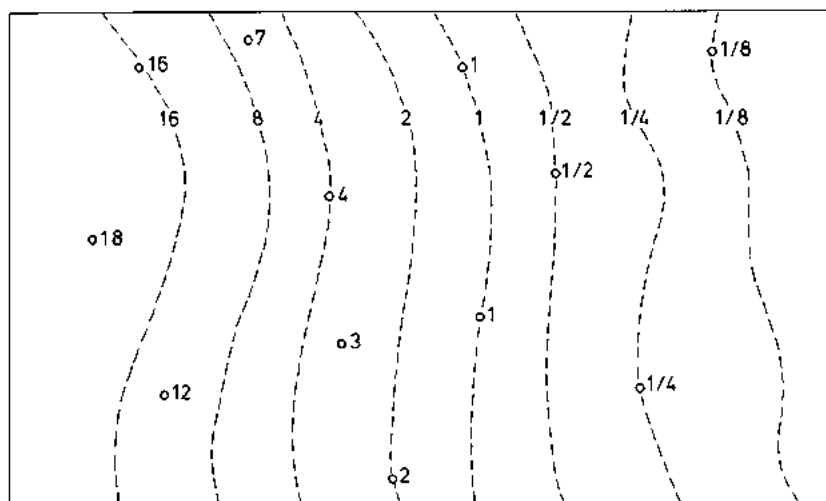

Fig. 2.15 Example of a sand-clay ratio map

Because of the wide range from zero to infinity, it is recommended that the contour line of value 1.0 be drawn first, followed by contour lines of 2, 4, 8, etc., on one side, and 1/2, 1/4, 1/8, etc., on the other. For a correct interpretation of the map, an isopach map of the stratigraphic unit should also be available or the two maps should be combined.

2.2.7 Aquifer characteristics

The magnitude and spatial distribution of the aquifer characteristics must be specified. Depending on the type of aquifer (Fig. 2.5), these characteristics may be:

- hydraulic conductivity, K (for all types of aquifers)
- storage coefficient, S (for confined and semi-confined aquifers)
- specific yield, μ (for unconfined aquifers)
- hydraulic conductivity, K' (for the confining layer overlying a semi-confined aquifer).
- specific yield, μ' (for the confining layer overlying a semi-confined aquifer)

Various field, laboratory, and numerical methods are available to determine or estimate these characteristics.

Estimating KD or K from in-situ test data

Without any doubt, aquifer tests are the most reliable methods of determining aquifer characteristics. We shall assume that the reader is familiar with these tests. If not, we refer him to Kruseman and de Ridder (1970).

A disadvantage of aquifer tests is their high cost. In regional groundwater studies usually only a few such tests can be performed and the data they provide are not sufficient to compile the maps of hydraulic conductivity, storage coefficient, or specific yield that are needed for proper aquifer modelling. Supplementary data thus have to be collected by other, perhaps less accurate, methods. An advantage of some of these methods, however, is that they can be used on existing wells or bore holes. Examples are:

- well test
- slug test
- point test

A *well test* consists of pumping an existing small-diameter well at a constant rate and measuring the drawdown in the well. When, after some time, the water level has approximately stabilized, steady flow conditions

can be assumed and a modification of the Thiem equation can be used to calculate the transmissivity:

$$KD = \frac{1.22 Q}{s_w} \quad (2.1)$$

where

Q = the constant well discharge in m^3/d ,

s_w = the stabilized drawdown inside the well at steady flow in m,

K = the hydraulic conductivity of the aquifer for horizontal flow in m/d ,

D = the thickness of the aquifer in m.

This equation expresses that the transmissivity, KD , approximately equals the specific capacity of the well, i.e. the yield of the well per metre drawdown. A well test can be applied to both confined and unconfined aquifers, although for unconfined aquifers, the drawdown s_w must be corrected: $s'_w = s_w - (s_w^2/2D)$, where D is the saturated aquifer thickness in m.

Note: Appreciable errors can be made in calculating the transmissivity in this way, especially when information on the well construction is not available, or when the well screen is partly clogged. Reasonable estimates of KD can also be made by applying Jacob's method to the time-drawdown and time-recovery data from a pumped well (see Kruseman and de Ridder 1970).

A *slug test* consists of abruptly removing a certain volume of water from a well, either with a high-capacity pump or with a bucket or bailer, and measuring the rate of rise of the water level in the well. The slug of water removed must be large enough to lower the water level by some 10 to 50 cm. Ferris et al. (1962) and Cooper et al. (1967) presented formulas for calculating the transmissivity and specific yield of an unconfined aquifer if the well fully penetrates the aquifer. Bouwer and Rice (1976), see also Bouwer (1978), gave the following equations for partially- and fully-penetrating wells in an unconfined aquifer (Fig. 2.16):

$$K = \frac{r_c^2 \ln(R_e/r_w)}{2L_e} \frac{1}{t} \ln \frac{y_o}{y_t} \quad (2.2)$$

If $L_w = D$ (fully penetrating well) then

$$\ln \frac{R_e}{r_w} = \left[\frac{1.1}{\ln(L_w/r_w)} + \frac{C}{L_e/r_w} \right]^{-1} \quad (2.3)$$

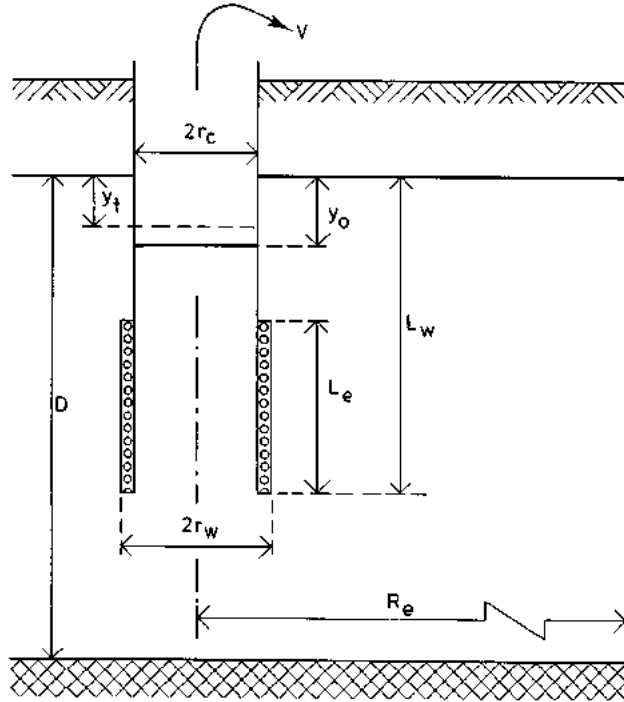

Fig. 2.16 Slug test in unconfined aquifer

Values of y_t for different times fall on a straight line when plotted on semi-logarithmic paper. For a given value of L_e/r_w the corresponding value of C must be read from a graph.

A *point test* is a permeability test made while drilling an exploratory bore hole. When the hole has reached the required depth, a small screen, whose length equals its diameter, is lowered into the hole. After the casing has been pulled up over a certain distance and a packer has been placed to close the annular space, the water level in the pipe is lowered by a compressor. When the water level in the pipe has stabilized, the pressure is released and the rate of rise of the water level in the pipe is measured. Bruggeman (1976) gave the following equation for the change in water level:

$$s_t = h e^{-4Ktr_b r_c^2} \quad (2.4)$$

where

s_t = drawdown at time t with respect to the initial water level (m)

h = height of the depressed water column (m)

t = time since the air pressure was released (days)

K = hydraulic conductivity (m/d)

r_b = radius of the screen (m)

r_c = radius of the pipe (m)

The measured water levels are plotted against the corresponding time on semi-logarithmic paper (the time on the arithmetic scale). The points fall on a straight line, the slope of which can be determined. The hydraulic conductivity of the aquifer material at the depth of the screen is then found from

$$K = 0.575 \frac{r_c^2}{r_b} \frac{1}{\Delta t} \quad (2.5)$$

If the water level is lowered by pumping, steady flow is reached within a few minutes. For this flow condition, the following equation can be used to calculate the hydraulic conductivity:

$$K = \frac{Q}{4\pi sr_b} \quad (2.6)$$

When applying these formulas, one should take into account the skin factor (resistance of the screen), the storage of water in the pipe, and the inertia forces of the water in the pipe (Uffink 1979). While drilling a bore hole, one can make this test at different depths of the aquifer and can then calculate a weighted mean hydraulic conductivity for the whole aquifer.

Estimating K from grain size

Since in regional groundwater studies one is more interested in obtaining the order of magnitude of K at as many places as possible in the basin, rather than very accurate values at only a few places, the method of estimating K from grain size can be a valuable addition to more accurate, but costly, aquifer tests.

Grain size distribution is commonly expressed by a single parameter: median (M), or specific surface of the sand fraction (U). The specific surface (U) is defined as the ratio of the total surface area of the particles to the surface area of an equal quantity, by weight, of spherical particles of the same material with a diameter of 1 cm.

Assume w gram of material whose particles are spheres with a diameter of d cm and a mass density ρ ; the number of particles in w gram material is then:

$$\frac{w}{(1/6)\pi d^3 \rho} = \frac{6w}{\pi d^3 \rho}$$

and the total surface area of these particles is:

$$\frac{6w}{\pi d^3 \rho} \pi d^2 = \frac{6w}{d\rho} \text{ cm}^2$$

The total surface area of w gram of the particles with a diameter of 1 cm is therefore $6w/\rho \text{ cm}^2$. The specific surface of the material is

$$U = \frac{6w/d\rho}{6w/\rho} = \frac{1}{d} \quad (2.7)$$

Aquifer materials do not generally consist of uniform particles of one single diameter but of particles of different sizes to be grouped in fractions, each with certain limits of particle size. This grouping is used to classify the sands. Table 2.2 gives the classification system, the particle size limits, and corresponding value of U.

Table 2.2 Classification of sandy materials, grain size limits, and corresponding specific surface (U)

Description	Particle size limits (micron)		$U = \frac{1}{2} \left(\frac{1}{d_1} + \frac{1}{d_2} \right)$
	d_1	d_2	d in cm
Silt	16	63	$\frac{1}{2}(625 + 160) = 390$
Very fine sand	63	83	$\frac{1}{2}(160 + 120) = 140$
Fine sand	83	125	$\frac{1}{2}(120 + 80) = 100$
Moderately fine sand	125	200	$\frac{1}{2}(80 + 50) = 65$
Moderately coarse sand	200	333	$\frac{1}{2}(50 + 30) = 40$
Coarse sand	333	500	$\frac{1}{2}(30 + 20) = 25$
Very coarse sand	500	1,000	$\frac{1}{2}(20 + 10) = 15$
Extremely coarse sand	1,000	2,000	$\frac{1}{2}(10 + 5) = 7.5$

The specific surface (U) of sand samples of different fractions is usually determined from the results of a mechanical analysis of the samples for which a set of standard sieves is used. After sieving the sample, one weighs the material left behind on each sieve and multiplies the weight with the corresponding U-values. To find the U-value, the results are summed and divided by the total weight of the sample:

$$U_{\text{sample}} = \frac{\sum U_i W_i}{W_{\text{tot}}} \quad (2.8)$$

The relation between the hydraulic conductivity and grain size distribution of sandy materials has been the subject of numerous investigations. If the U-value is chosen as a parameter for the grain size distribution, it appears that in all the formulas the hydraulic conductivity is inversely proportional to U^2 . For homogeneous sands, free of clay, the following equation applies:

$$K = \frac{C}{U^2} \frac{p^3}{(1-p)^2} \quad (2.9)$$

where

p = porosity of the sand

C = a factor representing the influence of the shape of the particles and the voids

Various investigations have shown that the proportionality factor between K (in m/d) and $1/U^2$, or the product KU^2 , varies from 31×10^3 to 71×10^3 at a porosity of the sand $p = 0.40$. Most values range from 31×10^3 to 45×10^3 (de Ridder and Wit 1965).

For conditions in The Netherlands, Ernst (unpublished research) found that the following empirical equation gave the best results when compared with aquifer tests:

$$K = 54,000 U^{-2} C_{so} C_{cl} C_{gr} \quad (2.10)$$

where

K = hydraulic conductivity, m/d

U = specific surface of the main sand fraction

C_{so} = correction factor for the sorting of the sand

C_{cl} = correction factor for the presence of particles smaller than 16 microns

C_{gr} = correction factor for the presence of gravel

Figure 2.17 shows a graphical representation of these correction factors.

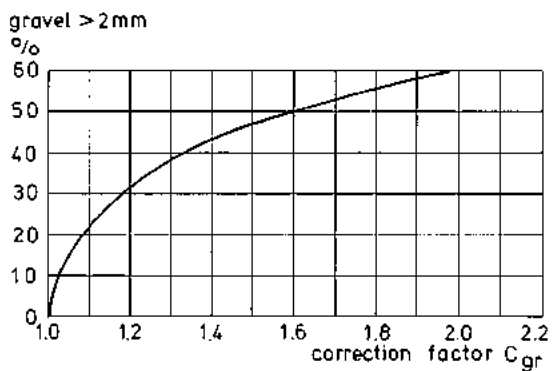
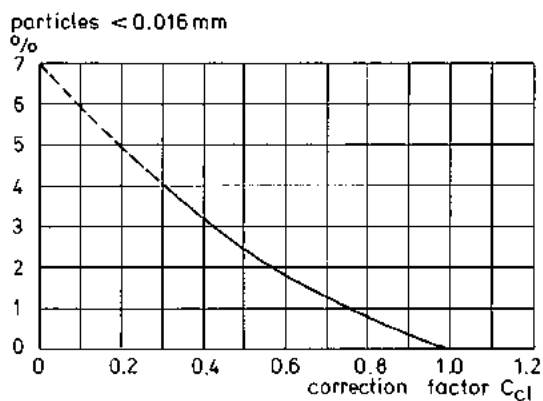
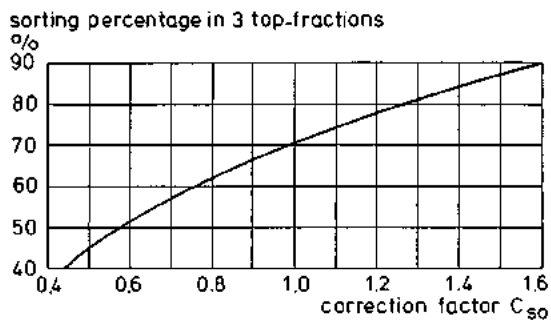

Fig. 2.17 Correction factors for estimating hydraulic conductivity of sands from grain-size distribution expressed in specific surface (U)

The factors C_{so} takes into account the sorting of the sand, taken as the total percentage by weight of the three neighbouring subfractions in which the abundance of grains is greatest. For a sorting of 70 per cent, the correction factor is 1; for a higher sorting it is greater than 1, and for a lower sorting it is less than 1.

Clay reduces the hydraulic conductivity of a sand. If the sand sample contains more than 6 per cent particles smaller than 16 microns, the method cannot be used.

If gravel occurs intermixed with sand, it obstructs the flow of water and consequently decreases hydraulic conductivity. Normally, however, gravel occurs as separate layers whose hydraulic conductivity is high. In the graph for the C_{gr} factor, only this effect is considered. The factor C_{gr} is greater than 1.

To give an example, suppose a sample is classified as fine sand, with a sorting of 60 per cent of the grains in the top three fractions, approximately 2 per cent particles smaller than 16 microns, and no gravel. The hydraulic conductivity of the sand is (Eq. 2.10):

$$K = 54,000 \times 100^{-2} \times 0.76 \times 0.58 \times 1.0 = 2.4 \text{ m/d}$$

The grain-size method can be used to estimate the hydraulic conductivity of sandy materials found in old and new bore holes, provided that their logs are available and that the logs give sufficient details on the grain size distribution and on the clay and gravel contents of the layers pierced.

The procedure of estimating an aquifer's transmissivity and weighted mean hydraulic conductivity from grain size data is as follows (Fig. 2.18). Using the classification of Table 2.2 and Eq. 2.10, one calculates the hydraulic conductivity of the materials described for each layer. These K -values are multiplied by the thickness of the individual layers. The sum of these KD values is the transmissivity of the aquifer. Dividing the sum by the total thickness of the aquifer gives the weighted mean hydraulic conductivity, \bar{K} , of the aquifer.

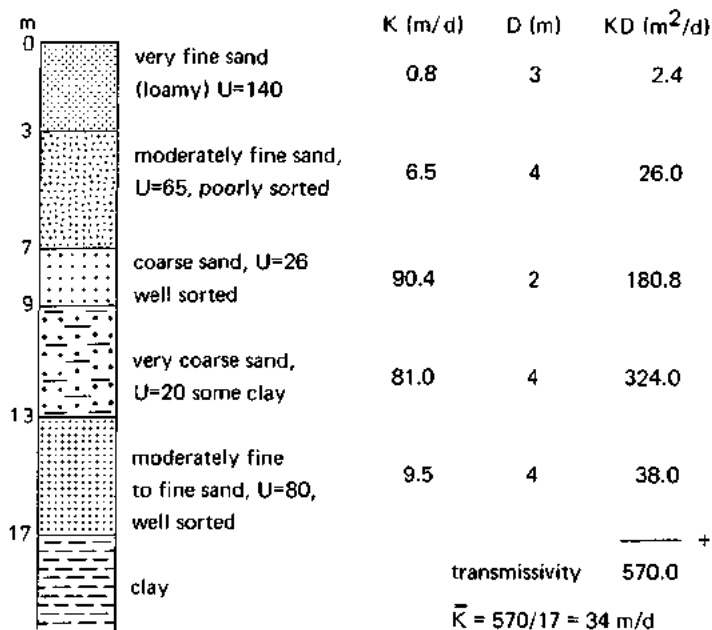

Fig. 2.18 Estimating transmissivity from grain sizes described in a bore log

Analyzing grain-size distribution of large numbers of samples in the laboratory and calculating U-values is time-consuming and costly. Experienced field staff, using only a magnifying glass with built-in measuring scale or a sand ruler that contains small quantities of the subfractions given in Table 2.2, are often capable of making fairly good estimates of the average grain size (U) of dried samples, their sorting, and their clay and gravel contents. The grain-size method can also be applied to these estimates to obtain an average K and KD of an aquifer. Experience has shown, however, that the greatest errors in estimating U are made in the two extreme grain size classes: silts to very fine sands, and very coarse to extremely coarse sands. It is obvious that estimates of K and KD made in this way give only an order of magnitude of these characteristics and that appreciable errors can be made.

It should also be noted that the proportionality factor of 54,000 in Eq. 2.10 may not be valid for all depositional environments. We would therefore suggest that the method first be applied at aquifer test sites and that average KD values be obtained from samples and/or well logs of the observation wells. If the average of these estimates compares well with the KD value found from the aquifer test, the method can be applied. If the comparison is not good, the procedure should be repeated using an adjusted proportionality factor.

Flow net method

In those parts of a basin where no aquifer tests have been conducted and where no well or bore logs are available, an indirect method of estimating the aquifer transmissivity can be used. For this purpose one needs an accurate watertable-contour map on which one sketches stream lines orthogonally to the contour lines so that a flow net is obtained (Fig. 2.19). If KD is known for one segment of a stream tube, for example because an aquifer test has been made there, KD of the other segments in the stream tube can be calculated by using Darcy's formula in each segment in succession.

If $(KD)_A$ is known, then $(KD)_B$ in the next segment is found from

$$(KD)_B = \frac{q_B L_B W_A \Delta h_A}{q_A L_A W_B \Delta h_B} (KD)_A \quad (2.11)$$

where

- q_A = flow in segment A (m^3/d)
- W_A = average width of Segment A
- L_A = average length of Segment A
- Δh_A = potential drop across Segment A

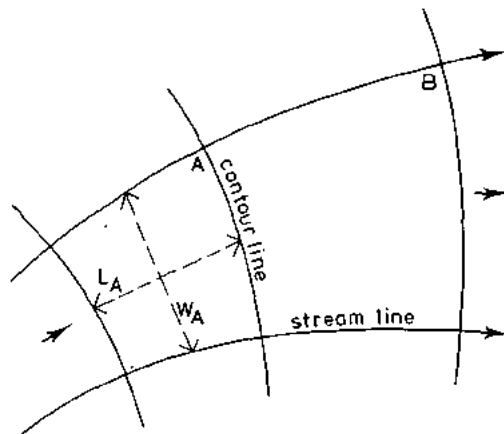

Fig. 2.19 Flow net for calculating the transmissivity KD in consecutive segments of a stream tube

In this way, one can obtain the spatial distribution of KD for the whole length of the stream tube. The ratio q_B/q_A represents the relative change in flow in the stream tube due to recharge and discharge of groundwater. If q can be regarded as a constant, the ratio can be taken as one, otherwise the various recharge and discharge terms must be known to determine the q_B/q_A ratio.

Other methods

Several other techniques of determining aquifer characteristics exist, but their application is restricted to specific hydrogeological conditions. In coastal aquifers in direct contact with the ocean, for instance, the transmission of tidal waves in the aquifer can be measured in a few observation wells placed on a line perpendicular to the coast. The water level data can then be used to calculate the aquifer characteristics (Todd 1980; Wesseling 1959, 1973; de Ridder and Wit 1965; van der Kamp 1973).

In a riverine area receiving steady seepage from a river, the leakage factor of a semi-confined aquifer can be determined in a similar way, i.e. by using water level data from a few observation wells placed on a line perpendicular to the river (Wesseling 1973).

Observing the change in watertable after an instantaneous change in the water level of a (straight) river tract or canal allows the value of $(KD/\mu)^{\frac{1}{2}}$ of an unconfined aquifer to be calculated (Edelman 1947, 1972; Stallman 1962; Huisman 1972).

Finally, the water balance method can be used to calculate the hydraulic resistance of the confining layer overlying a semi-confined aquifer (see Section 4 of this Chapter).

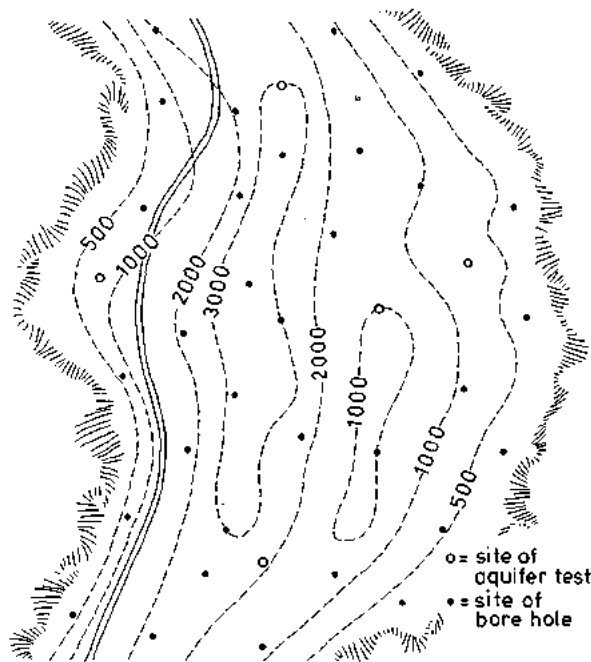

Fig. 2.20 Aquifer transmissivity of a hypothetical basin in m^2/d

Hydraulic conductivity map

The model requires quantitative data of the aquifer's hydraulic conductivity. For this purpose the transmissivity data obtained from aquifer tests, well tests, slug tests, point tests, and estimates from well or bore logs and flow-net calculations should all be used to compile a (preliminary) transmissivity map (Fig. 2.20). A hydraulic conductivity map can then be compiled. To do so, one superimposes the transmissivity map on the isopach map (Fig. 2.17) and reads the thickness and the transmissivity at the intersections. One finds the hydraulic conductivity K at the intersections by dividing KD by D . These K -values are plotted on a separate map and lines of equal hydraulic conductivity are drawn.

Estimating specific yield

The specific yield, μ , is a characteristic property of unconfined aquifers. It is a dimensionless parameter that characterizes the storage capacity of such aquifers and is usually defined as the ratio of the drainable volume to the bulk volume of the aquifer, or the difference between the porosity and the specific retention, also known as field capacity or water-holding capacity.

The specific yield can be determined from the data of an aquifer test. Such tests, however, must last several days or even weeks to ensure that the calculated value of μ is reliable. Specific yield can be measured by a variety of other techniques. One can, for example, take soil samples and determine in the laboratory the difference between the volumetric-water content at saturation and the water content when most of the water has drained from the pores (water content at field capacity).

Another technique, often used in experimental fields, consists of measuring the drop in watertable, Δh , and the amount of water drained from the field, Q . The specific yield is found by dividing the quantity of drainage water by the drop in watertable ($\mu = (Q/A)/\Delta h$, where A is the area).

In large groundwater basins, any of these techniques are time-consuming and therefore costly, so their use will probably be limited to just a few sites. This produces a far from reliable picture of the areal distribution of the specific yield. An experienced hydrogeologist may be able to estimate the specific yield from data on grain size. If so, these estimates can be valuable additions to the few, more precise, data collected by other means.

To estimate the specific yield of an unconfined aquifer (or a covering confining layer) from available bore or well logs, one follows the same procedure as outlined in Figure 2.18. Orders of magnitude for specific yield of different materials are (Table 2.3):

Table 2.3 Orders of magnitude and ranges for specific yield of different materials (after Morris and Johnson 1967)

Type of material	Specific yield (per cent)	
	Range	Mean
Coarse gravel	13 - 25	21
Medium gravel	17 - 44	24
Fine gravel	13 - 40	28
Coarse sand	18 - 43	30
Medium sand	16 - 46	32
Fine sand	1 - 46	33
Silt	1 - 39	20
Clay	1 - 18	6
Loess	14 - 22	18
Eolian sand	32 - 47	38
Tuff	2 - 47	21
Sandstone (fine)	2 - 40	21
Sandstone (medium)	12 - 41	27
Siltstone	1 - 33	12

Note that for all the control points in the area a weighted mean specific yield should be calculated for the zone in which the watertable fluctuates

or is expected to fluctuate in the future. To be on the safe side, one should make the calculations from the land surface down to some 10 to 15 m below the present mean watertable elevation.

Estimating storage coefficient

The storage coefficient of a confined or semi-confined aquifer cannot be derived from grain size data, but is usually determined from field test data (aquifer tests). Since the storage coefficient is a function of the depth and thickness of the aquifer, its order of magnitude can also be estimated, using the following equation:

$$S = 1.8 \times 10^{-6} (d_2 - d_1) + 8.6 \times 10^{-4} (d_2^{0.3} - d_1^{0.3}) \quad (2.12)$$

where d_1 and d_2 are the depths of the upper and lower surface of the aquifer below ground surface, respectively (van der Gun 1979). S can be estimated from Figure 2.21.

The logs of all existing, fully penetrating wells and bores can thus be used to estimate the storage coefficient of confined and semi-confined aquifers. These data, together with the data on storage coefficients derived from aquifer tests, are plotted on a map and lines of equal storage coefficient are drawn.

Note: In the above discussion we have emphasized the efforts that should be made to obtain as complete a picture of the magnitude and spatial distribution of the aquifer characteristics as possible. Owing to the geological complexity of most aquifers and to the inaccuracies involved when applying the methods we have described, the picture will never be complete, nor can the values of the aquifer characteristics be precise. One should therefore not be surprised, when calibrating the model, to find that even the best maps of hydraulic conductivity, storage coefficient, and specific yield need adjustment. The hydrogeologist's main task is therefore, to determine the order of magnitude of these parameters in different parts of the basin

and, on the basis of a proper knowledge of the lithological variations within an aquifer and its confining layer, if present, to indicate the range within which the parameter values may vary. As shown in Table 2.3, the range for specific yield of different granular materials is fairly wide.

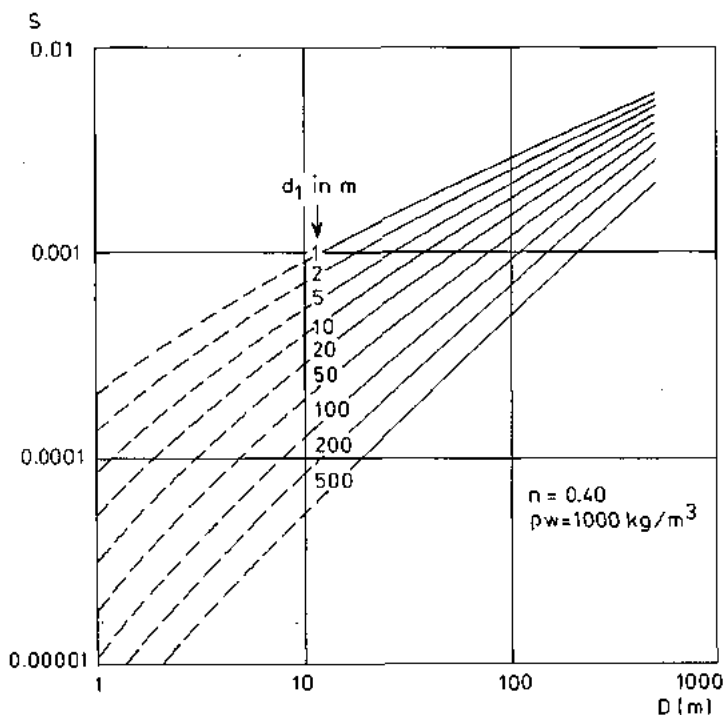

Fig. 2.21 Coefficient of elastic storage as a function of aquifer thickness (D) and depth (d_1) below the aquifer surface. Nomograph based on Eq. 2.12 (after van der Gun 1979)

2.3 Hydrological stress

Hydrological stress exerted on a groundwater basin - from the infiltration of rainfall and/or irrigation water, from stream-bed percolation, evapotranspiration, groundwater discharge by streams and springs, and pumping

from wells - is reflected in the configuration and fluctuation of the watertable in the basin. As part of the hydrogeological investigations, a watertable survey should therefore be made.

The development of a groundwater basin model requires that sufficient and reliable data on the watertable be available because the model is calibrated by "history matching". This means that computed watertable elevations are compared with actually measured ones. The collection and evaluation of watertable data is therefore an important part of groundwater basin modelling.

2.3.1 Watertable elevation

To study the magnitude and distribution of the hydraulic head in a basin, an appropriate network of observation wells and/or piezometers must be established throughout the basin and along its boundaries. The number and spacing of the wells and piezometers depends on the size and hydrogeological conditions of the basin, and on the type of problem that is to be studied.

For confined and unconfined aquifers, sets of single observation wells will suffice, but for semi-confined aquifers, sets of double observation wells or piezometers are needed: one set in the aquifer and one set in the covering poorly permeable layer.

In selecting proper sites for observation wells, one must consider variations in aquifer thickness, lateral and vertical variations in the aquifer's lithology, and the structural deformation of the aquifer, if any. More observation wells than elsewhere are needed in local recharge areas (e.g. irrigated areas), in local discharge areas (e.g. areas where groundwater is abstracted from wells), and in areas where abrupt changes in hydraulic gradient occur (e.g. near a fault). Special observation wells are needed to specify the conditions at the aquifer's boundaries. Gauging stations in surface water courses and surface water bodies (lakes, seas, and oceans) should be established and included in the network.

Once the network of observation wells has been established, the water levels in all the wells should be measured at least once a month and for at least one year. Preferably the measurements should extend over two or more years. For specific, local problems, more frequent water level readings may be required, say weekly or even daily.

The water level data are used to draw the following maps:

- watertable-contour map
- depth-to-watertable map
- watertable-change map
- head-difference map (if applicable).

To start the computer calculations, one must know the initial watertable elevations throughout the basin. For this purpose a watertable-contour map at the starting date of the calculations must be made. To calibrate the model, such maps are also needed for each successive time unit chosen for modelling. If the time unit is a month, monthly watertable-contour maps over the whole calculation period are needed.

To explain any anomalies in hydraulic gradients and any groundwater mounds and depressions, the watertable contour map should be studied in combination with the geological data. Any human activities that may affect the watertable should also be taken into account.

For a semi-confined aquifer, two watertable-contour maps must be drawn: one for the aquifer, and one for the covering layer.

Although not required for the model, maps of the depth-to-watertable, watertable fluctuations, and head-differences can provide a valuable insight into the hydrogeological conditions of the basin and its groundwater regime.

Note. Our model is based on the assumption that the aquifer to be modelled contains fresh water whose mass density is approximately the same throughout the aquifer. Variations in mass density, which may occur in both horizontal and vertical directions cannot be simulated by the model.

Groundwater density is a function of salinity and temperature. To determine the salinity of the groundwater, water samples are taken in a number of

representative observation wells and piezometers placed at different depths, and their total dissolved solids content or electrical conductivity is determined. Geoelectrical prospecting can be a valuable addition to these findings. The results obtained should be plotted on a map, and lines of equal total dissolved solids content or electrical conductivity are then drawn. If these maps reveal great variations in salinity, it will not be possible to develop the model.

It may happen, however, that the groundwater in the major part of the basin is fresh, but salty in a minor part or along the boundary. To compile a contour map of the watertable or potentiometric surface, the water level readings from observation wells and piezometers placed in the salty groundwater must be corrected for the difference in mass density. For horizontal flow the pressure distribution in the water is hydrostatic. If the interface between fresh and salt water is sharp and we assume a horizontal reference level coinciding with the bottom of the piezometers ($z = 0$), we can convert the water level h_2 of the piezometer in the salty groundwater with a mass density ρ_2 into a water level for the fresh water with mass density ρ_1 , using the following equation (Fig. 2.22):

$$h_2 \text{ (fresh water)} = h_2 \frac{\rho_2}{\rho_1} \quad (2.13)$$

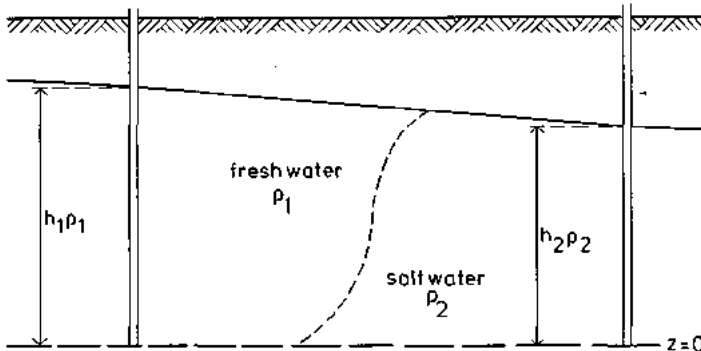

Fig. 2.22 Aquifer with fresh and salt groundwater with a sharp interface

2.3.2 Type and extent of recharge areas

Estimating the recharge of an aquifer forms a basic part of any groundwater study, and it is not the easiest part. The difficulty is that the process by which rainfall or surface water infiltrates into the soil, moves downward through the unsaturated zone, and eventually joins the groundwater as "deep percolation" is not well understood. In arid zones, where rainfall is scanty and irregularly distributed in space and time, the problem takes on even larger dimensions than in humid zones.

The type and extent of recharge areas and the sources of recharge should first be determined. Although they will differ for different types of aquifers, the main factors governing the recharge of all aquifers are topography, surface geology, and climate.

Confined aquifers, as occur in deep downwarped basins, are usually recharged along the rim of the basin where the formations containing the aquifer outcrop on the surface. A portion of the rain that falls on these outcrops infiltrates and joins the groundwater. Aerial photographs can be used to delineate these outcrops and to determine their areal extent. A field survey is needed to specify the types of rock or sediments that make up the outcrops. Besides percolation of rainfall, other sources of recharge can be stream-bed percolation and surface runoff from adjacent hilly terrain. The amounts of deep percolation of each component should be specified either by taking direct measurements or - as is usually done - by determining the deep percolation as the residual of the amounts of surface water supply, use, and discharge. Relatively small errors in these amounts, however, may cause large errors in the estimated deep percolation because deep percolation constitutes only a small proportion of the surface water supply, use, and discharge.

Another source of recharge to confined aquifers may be water migrating through confining layers within the basin. Few confining layers are truly impermeable, unless they lie at great depth and are thick and strongly compacted by a thick overburden.

Other recharge zones occur in the vicinity of positive relief features (interfluves, high grounds, mountain formations). These zones are character-

ized by a convexity of the aquifer's piezometric surface and by water pressures that diminish with depth, thereby indicating the existence of downward flow through underlying poorly permeable confining layers.

Hence, to delineate and specify recharge zones, not only aerial photographs should be studied, but also the piezometric surface in relation to the relief and the exchange of water through confining layers. If such an exchange of water occurs, the aquifer is not truly confined, but is instead semi-confined.

Unconfined aquifers with a deep watertable are recharged by rainfall percolation, stream-bed percolation and, in irrigated areas, irrigation percolation (percolation from the canal system and from the fields). Here too, the convexity of the watertable under stream channels, main irrigation canals, and irrigated fields is proof of such recharge (Fig. 2.23).

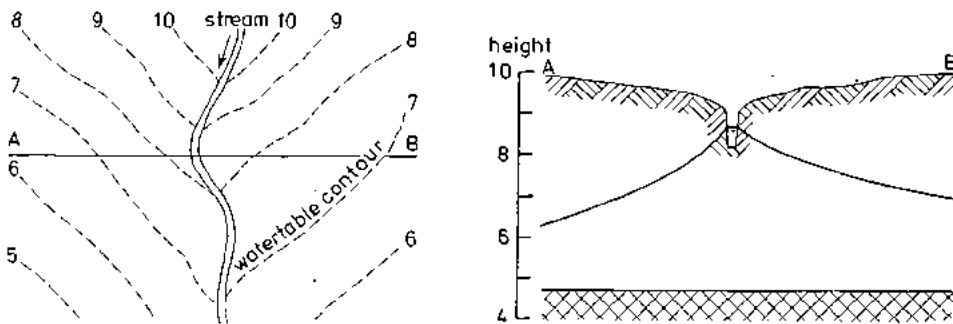

Fig. 2.23 Example of a losing stream.

Watertable-contour map.

Cross-section over stream valley; convex watertable under stream channel due to percolation from stream bed.

The surface of an unconfined aquifer is seldom entirely flat. Instead it shows minor and sometimes major relief features such as interfluves, sand ridges, and sand hills. In unconfined aquifers with relatively shallow watertables, these high grounds are the recharge areas.

Characteristic of these recharge areas are the convexity of the watertable and relatively large watertable fluctuations (Fig. 2.24), and also a low salt content of the groundwater and an anomalous temperature gradient in the groundwater. In the temperate zones with excess rain in the cool seasons, for example, recharge areas are characterized by "too low" a temperature in the zone where the annual temperature wave is negligible, i.e. below a depth of approximately 25 m.

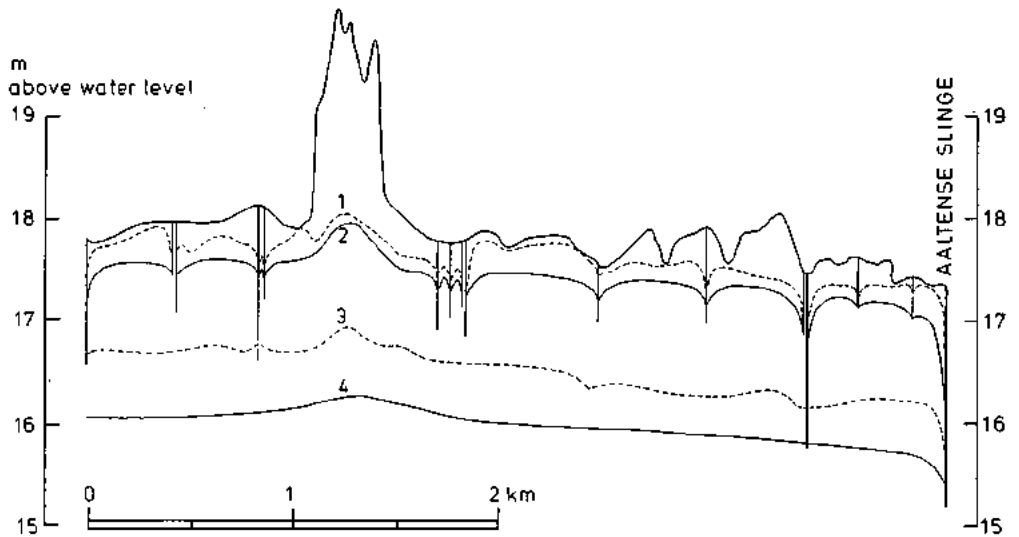

Fig. 2.24 Section through an undulating sandy area showing average summer and winter watertables and the corresponding water levels in brooks and rivulets (Ernst et al. 1970).

- Curve 1: December 1965
- Curve 2: Average winter level
- Curve 3: September 1965
- Curve 4: Average summer level

2.3.3 Rate of recharge

Several methods can be used to estimate the recharge of unconfined aquifers. (Some of these methods can also be used on the outcrops of confined aquifers.)

Groundwater flow

The first method involves a study of the groundwater flow. Some aquifers are drained by springs. Measuring the discharge of the springs gives an indication of the recharge. If most of the recharge occurs just upstream of an aquifer, Darcy's formula can be used to calculate the groundwater flow through a section of the aquifer downstream of the recharge area:

$$Q = KD \frac{dh}{dx} B n \quad (2.14)$$

where

Q = the flow over a period of n days

dh/dx = the hydraulic gradient

B = the width of the section

An advantage of this method is that it covers all recharge from rainfall and percolating surface water from streams and water courses and can be used for both confined and unconfined aquifers. Seasonal variations in Q are in accordance with seasonal variations in the hydraulic gradient. Of course, to apply this method one must have an accurate watertable-contour map and accurate data on the transmissivity of the aquifer.

Rainfall-watertable relation

The second method involves the elaboration of data on rainfall and/or irrigation water supply, and data on the seasonal variations in watertable.

As this method refers to recharge at the surface only, it cannot be used for truly confined aquifers, except at their outcrops along the rim of the basin. If the watertable is relatively deep and there is a seasonal recharge from rainfall (or irrigation), the watertable will fluctuate as shown in Figure 2.25.

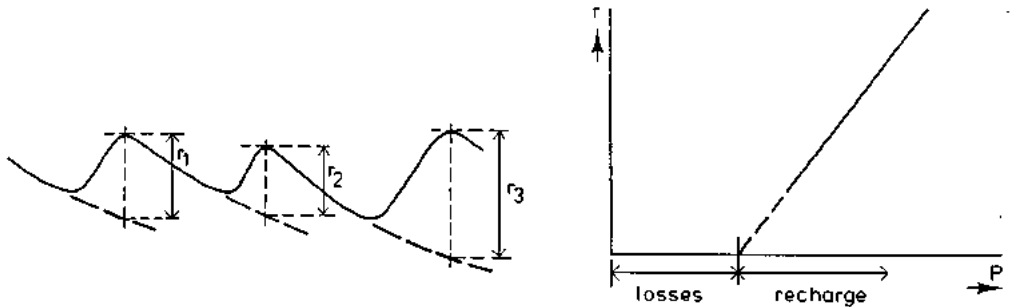

Fig. 2.25 Computation of annual recharge from seasonal variations in watertable due to rainfall or irrigation

The annual rise in watertable (r) is plotted against the corresponding annual rainfall (P), so that an average relationship between the two quantities is established. Extrapolating the straight line until it intersects the abscis gives the amount of rainfall (or irrigation water) below which there is no recharge. Any quantity less than this amount is lost by evapotranspiration and runoff.

Runoff hydrograph

A third method involves the elaboration of data on discharge measurements of streams. A graph showing the discharge with respect to time is called a hydrograph. Any hydrograph can be regarded as a hydrograph of surface runoff superposed on a hydrograph of groundwater flow. To separate the two, Gray (1970) describes several methods. Although such separations are somewhat arbitrary and artificial, their results are more reliable than

otherwise when applied to flow regions with distinctly alternating wet and dry periods. Figure 2.26 shows such a situation.

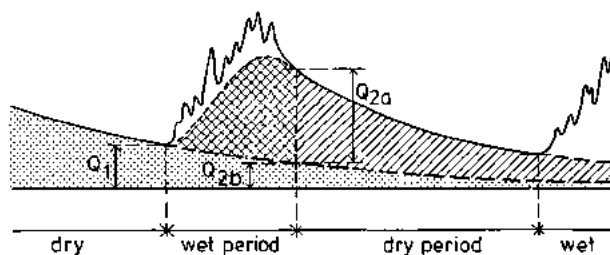

Fig. 2.26 The use of stream flow-depletion curves in assessing groundwater storage

The dotted area represents the groundwater outflow originating from the previous wet period; this flow slowly decreases, being Q_1 at the start of the next wet period and Q_{2b} at the end of that period. Because of the groundwater recharge in the wet period, the groundwater outflow increases. The amount of recharge is equal to the sum of the double hatched area (representing the additional groundwater outflow during the wet period) and the single hatched area (representing the additional groundwater outflow in the next dry period). The additional outflow in this dry period is caused by the increase in groundwater storage during the wet period. If a linear relation between groundwater outflow and groundwater storage is assumed, expressed by:

$$Q = \alpha S \quad (2.15)$$

the increase in groundwater storage can be indicated by Q_{2a}/α . The value of α can be derived from the slope of the depletion curve (which is the tail end of a hydrograph) drawn on semi-logarithmic paper. The recharge of the groundwater thus equals the double hatched area plus Q_{2a}/α .

Lysimeters

A fourth method involves lysimeter studies. A disadvantage of lysimeters is that they require natural soil blocks to be collected from different recharge areas. Moreover, the recharge measured from lysimeters refers only to the recharge from rainfall on the soil surface. Any other source of recharge, e.g. from lateral or upward inflow of groundwater, is not taken into account.

Tensiometers

A fifth method measures recharges by tensiometers installed in the upper 1 to 2 m of the soil profile. As the results obtained in this way apply only to a small area, many installations are required to cover an entire recharge area.

Isotopes

A sixth method includes the tritium tagging method. Tritium is injected, at a depth of about 70 cm, before the commencement of the rainy season. The injection sites are selected on the basis of geology, topography, drainage pattern, and soil type. After the rainy season, soil core samples are taken and the variation in tritium activity and moisture content with depth are measured. This allows the tracer movement to be estimated and the recharge to be calculated (Athavale et al. 1980).

Stream flow

In streams and water courses whose water levels are higher than the water-table in the adjacent land, one can obtain an idea of the amount of water that these streams lose to the underground by measuring the flow in different sections of the stream. The difference in flow between two measuring

points indicates the amount of water lost in the tract between those two points.

2.3.4 Type and extent of discharge areas

Discharge areas are areas where the aquifer loses water by overflow, evaporation, diversion, migration through confining layers, and pumpage. A study of topographical maps and aerial photographs, in addition to field surveys, will be of great help in determining the type of discharge areas and in delineating them.

The overflow may appear as springs or as general groundwater outflow that contributes to the flow of streams and other natural or artificial water courses (Figs. 2.27 and 2.28).

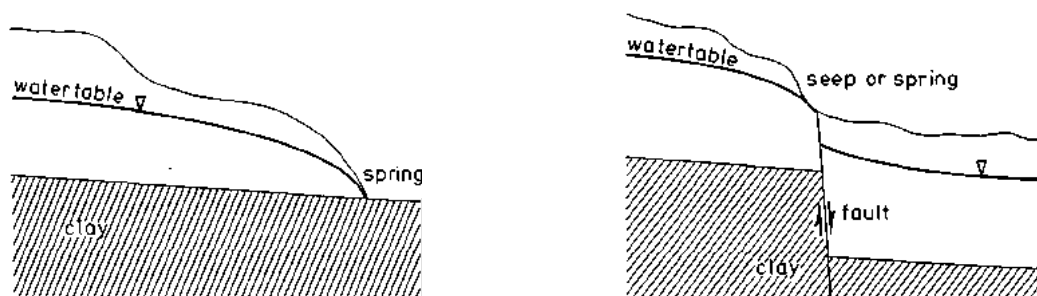

Fig. 2.27 Two types of springs. The fault acts as a barrier to groundwater flow

2.3.5 Rate of discharge

Springs

Springs are the most obvious form of groundwater discharge. They occur in all sizes, from small trickles to large streams. Their occurrence is

governed by local hydrogeological conditions. Some springs have a fairly constant discharge, but most of them have variable discharges: high during and after rain, low or nil in the dry season. Some aquifers lose water through large off-shore springs, e.g. aquifers on the island of Crete and other coastal aquifers along the Mediterranean Sea. To determine the total quantity of groundwater discharged by springs, regular measurements of their flows must be taken, say monthly or seasonally.

Stream-base-flow/watertable relation

In shallow watertable areas considerable quantities of groundwater are discharged by seepage into streams and smaller natural drainage channels (Fig. 2.28). Seepage of groundwater into a stream occurs when the watertable adjacent to the stream is higher than the water level in the stream.

The groundwater discharge towards stream channels can also be estimated from the separation of hydrographs (Section 3.3). Here one focuses not on flood hydrographs, which show short high-intensity rainfalls, but on the depletion curve of hydrographs during fair-weather periods when all flow to streams is contributed by groundwater discharge. Curves are then prepared by plotting the mean watertable elevations within a basin against the corresponding groundwater discharges (Fig. 2.29).

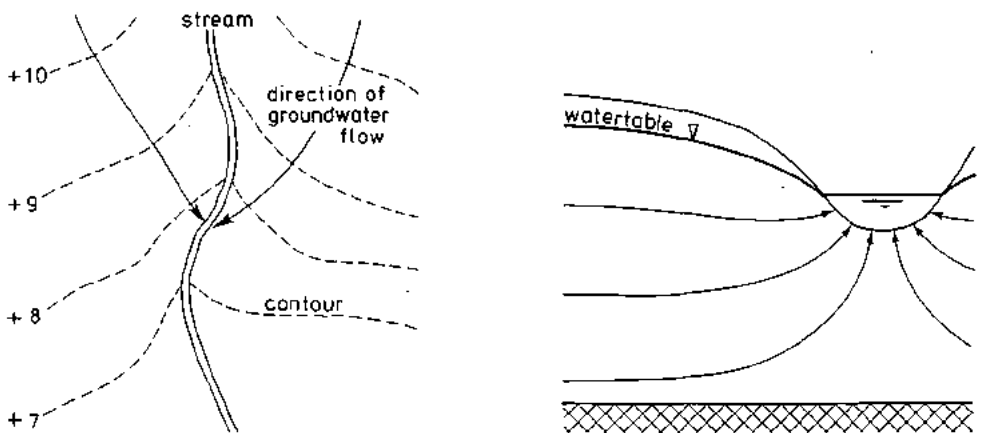

Fig. 2.28 Unconfined aquifer draining into a stream

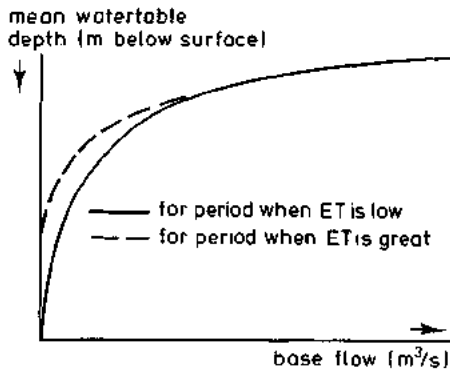

Fig. 2.29 Rating curve of mean watertable elevation compared with base flow

In areas with distinct hot and cold seasons two curves will be obtained, one for the hot season when evapotranspiration from groundwater is high, and one for the cold season when evapotranspiration is so low that it can be neglected. With these rating curves and the mean watertable depths for one year, surface runoff and base flow can be separated from a stream hydrograph (Fig. 2.30).

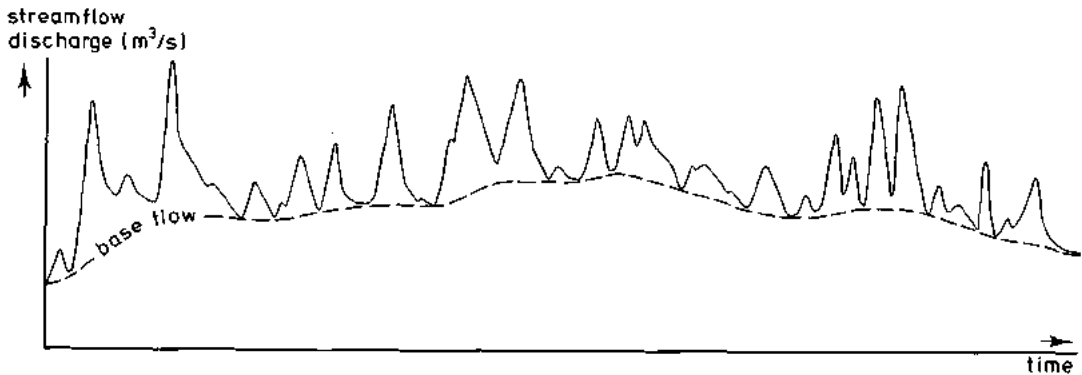

Fig. 2.30 Streamflow hydrograph in which surface runoff and base flow components have been separated

Evapotranspiration

Evapotranspiration is the combined effect of the evaporation of water from moist soil and the transpiration of water by natural vegetation and cultivated crops. Determining these water losses to the atmosphere is not an easy task; cooperation with an agronomist specialized in the subject may be necessary to obtain reliable information on this discharge.

First of all it should be recognized that many factors play a role in the evapotranspiration from a groundwater basin: climate, soils, soil water availability, soil fertility, crops, cropping pattern and intensity, environment and exposure, cultivation practices and irrigation methods. One must therefore compile a land use map indicating the areas covered with natural vegetation and cultivated crops, waste areas, bare soils, urban areas, surface water bodies, etc. Since the water consumption of various crops differ, a crop survey must be made and a map compiled of the cropping pattern. A soils map and depth-to-watertable maps for the growing season should also be made, if they are not yet available. Existing climatological data should be collected and evaluated.

Because of the difficult and time-consuming procedures involved in obtaining direct measurements of water use by crops and natural vegetation, a large number of methods (more than 30) have been developed to calculate these values. Among these methods, the four most widely used are those of Blaney-Criddle, Penman, and the radiation and pan evaporation methods. The choice of method depends primarily on the type of climatic data available. It is beyond the scope of this book to describe these methods and we refer the reader to Doorenbos and Pruitt (1977) who give an excellent review of them.

In shallow watertable areas, the groundwater contributes to evapotranspiration through capillary rise. This discharge is determined by the depth of the groundwater below the root zone, the capillary and conductive properties of the soil, and the soil water content or soil water tension in the root zone. At certain depths below the root zone, depending on the type of soil and provided that impermeable layers do not occur, the groundwater will contribute less than 1 mm/d to the root zone. These depths may be

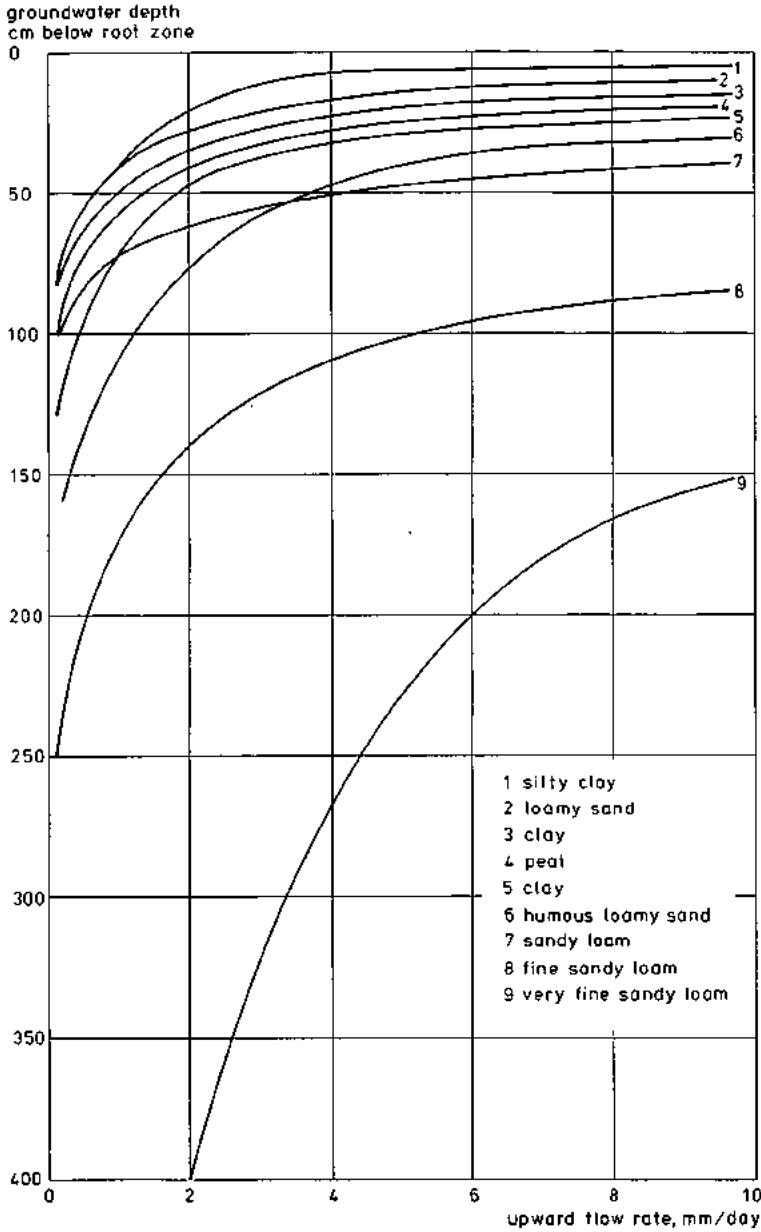

Fig. 2.3) Contribution of groundwater to the root zone in mm/d for different depths of the watertable below the root zone and for different soil types under moist conditions (soil water tension of root zone approximately 0.5 atm.) (after Doorenbos and Pruitt 1977)

taken at approximately 50 to 90 cm for coarse and heavy textured soils and about 120 to 200 cm for most medium textured soils (op.cit.). Figure 2.31 shows the upward rate of groundwater flow in mm/d for different depths of groundwater below the root zone and for different soil types, under the assumption that the soil in the root zone is relatively moist, i.e. soil water tension equals about 0.5 atm.

In practice, potential evapotranspiration is often estimated from a measured or calculated evaporation rate from a free water surface. A simple correlation between the two is then assumed to exist:

$$E_p = f E \quad (2.16)$$

where

E_p = the potential evapotranspiration rate

E = the evaporation from a free water surface

The empirical conversion factor f depends on the reflectivity of the crop, on the season, the climate, and the size of the cropped area. If differences in the factor f resulting from physiological variation of the crop during the growing season are disregarded, Table 2.4 can be used as a first approximation.

Table 2.4 Values of f , in $E_p = f E$ (after van der Molen 1971)

Crop	Values of the factor f , in $E_p = f E$					
	Humid			Arid or semi-arid		
	temperate		tropical	large area		small (less than 1 ha)
	winter	summer		winter	summer	summer
Wet, after rain or irrigation	0.9	1.0	1.0	1.0	1.2	1.5
Short grass	0.7	0.8	0.8	0.8	1.0	1.2
Tall crop (wheat, sugar cane)	0.8	1.0	1.0	1.0	1.2	1.5
Rice	1.0	1.0	1.2	1.0	1.3	1.6

On an annual basis, evapotranspiration can be estimated as being the difference between rainfall and total outflow from the area (surface water outflow, subsurface water outflow, and exported water, if any). Any changes in soil water storage, groundwater storage, and surface water storage are neglected because a long period is taken. Such changes cannot be neglected if shorter periods of, say, one day, one week, or one month are considered, which are precisely those used in groundwater modelling. To make a fair estimate of the monthly evapotranspiration losses, one must therefore conduct the extensive field surveys mentioned above, and use one or more of the appropriate calculation methods. The numerical model requires that the areal variations in the monthly evapotranspiration losses be specified.

Upward seepage

An aquifer can lose water by upward seepage through an overlying slightly permeable layer. Whether this happens can be determined by placing piezometers in the aquifer and in the overlying layer (Fig. 2.5C). If the head (h) in the aquifer is higher than the head of the free watertable in the covering layer (h'), the aquifer loses water by upward seepage. Consequently the watertable in the covering layer will rise to, or close to, the ground surface. Areas where such upward seepage occurs are usually moist or swampy and are real discharge areas. The water discharges by evapotranspiration of the rich natural vegetation and/or by small natural drainage channels.

The total discharge from such areas can be estimated by measuring the surface water outflow, if any, and by estimating the evapotranspiration, as discussed above. It can also be calculated with Darcy's equation:

$$q = K' \frac{h - h'}{D'} \quad (2.17)$$

where

q = rate of upward seepage (m/d)

K' = hydraulic conductivity of the covering layer for vertical flow
(m/d)

D' = saturated thickness of the covering layer (m)

h = hydraulic head in the aquifer (m)

h' = hydraulic head in the covering layer (m), see Fig. 2.5C

Note: $K'/D' = 1/c$, where c is the hydraulic resistance of the (saturated) covering layer, as is commonly determined from aquifer test data.

If the head difference ($h - h'$) is negative, as is often found in irrigated areas, the aquifer will gain water by vertical downward seepage through the covering layer.

Although our model cannot handle multi-aquifer systems, we must point out that the "impermeable" layer underlying the aquifer (Fig. 2.5C) may in fact not be impermeable. Depending on the head differences above and below that layer, the aquifer may lose or gain water through it. To find out whether this occurs, one must place double piezometers above and below the layer and determine its hydraulic resistance. The vertical exchange of groundwater through the layer can then be estimated.

Horizontal outflow

All types of aquifers may lose groundwater by lateral subsurface outflow through natural or imposed boundaries. The outflow rate must be determined or estimated, using the methods discussed earlier.

Groundwater abstraction

Finally, tube wells and pumping stations that abstract groundwater for domestic, industrial, or irrigation water supplies can be regarded as discharge areas. To estimate the total abstraction from the aquifer, an inventory of all pumped wells should be made. If pump records are not available, the yield of the wells can be measured and inquiries made about their time of operation (hours per day, days per week, weeks per months, and months per year that the wells are pumped). If available, data on fuel or electricity consumption can be used to estimate the daily or monthly abstraction of the wells.

2.4 Groundwater balance

The continuity concept requires that a balance must exist between the total quantity of water entering a basin and the total amount leaving the basin. In its most general form, the water balance equation (or the equation of hydrologic equilibrium) reads:

$$\left[\begin{array}{l} \text{surface inflow + subsurface inflow} \\ + \text{precipitation + imported water} \\ + \text{decrease in surface storage} \\ + \text{decrease in groundwater storage} \end{array} \right] = \left[\begin{array}{l} \text{surface outflow + subsurface outflow} \\ + \text{evapotranspiration + exported} \\ \text{water + increase in surface storage} \\ + \text{increase in groundwater storage} \end{array} \right]$$

The groundwater balance equation can be expressed as:

$$(Perc + Q_{per} + Q_{up} + Q_{lsi}) - (Et + Q_{dr} + Q_{do} + Q_{lso}) = \Delta S_{grw} \quad (2.18)$$

where (Fig. 2.32):

Perc = percolation of water from precipitation through the unsaturated zone to the watertable (effective precipitation)

Q_{per} = percolation of water through stream beds, other water courses, and surface water bodies which have water levels higher than the watertable in the adjacent land

Q_{up} = upward vertical seepage entering the aquifer through an underlying slightly permeable confining layer

Q_{lsi} = lateral subsurface inflow from adjacent areas which have a higher watertable than that in the aquifer

Et = evapotranspiration from shallow watertable areas (capillary rise from the shallow groundwater into the unsaturated zone and evapotranspiration)

Q_{dr} = outflow of groundwater into streams, open water courses, and other water bodies which have water levels lower than the watertable in the adjacent land

Q_{do} = downward vertical seepage leaving the aquifer through an underlying slightly permeable confining layer

- Q_{lso} = lateral subsurface outflow into adjacent areas which have a lower watertable than that in the aquifer
- ΔS_{grw} = change in groundwater storage

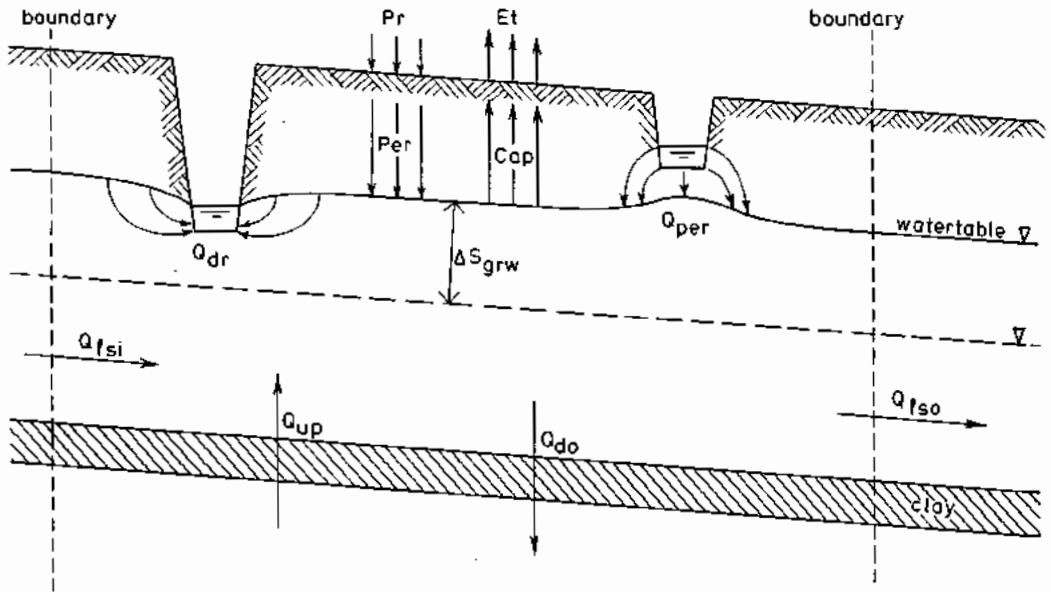

Fig. 2.32 Flow components for assessing a groundwater balance

Similarly, the water balance of the unsaturated zone can be written:

$$(Pr + Irr - R.off) - Et - W = \Delta S_{sm} \quad (2.19)$$

where (Fig. 2.33):

- Pr = precipitation
- Irr = irrigation water supply
- R.off = surface runoff
- Et = evapotranspiration
- W = (Perc - Cap), flow across the lower boundary of the soil water zone, where Perc is percolation and Cap is capillary rise. W can be positive or negative

ΔS_{sm} = change in soil water storage, where soil water storage is the amount of water retained by the soil up to a maximum of field capacity

When the hydrogeological investigations have been completed and the inflow and outflow components of the aquifer have been quantified, an overall groundwater balance of the basin must be assessed. This is needed because the model calculations include the computation of individual groundwater balances of the sub-areas into which the basin will be divided. On an annual basis, the sum of all these individual groundwater balances should agree with the basin's overall annual groundwater balance. The groundwater balance is thus one of the means of verifying the groundwater model, provided that all the inflow and outflow components have been correctly determined and that the equilibrium equation indeed balances. This will seldom happen, however, because some of its components are subject to minor or major errors. These errors must first be corrected by reconsidering the available data and the methods that had been used to quantify the components in question.

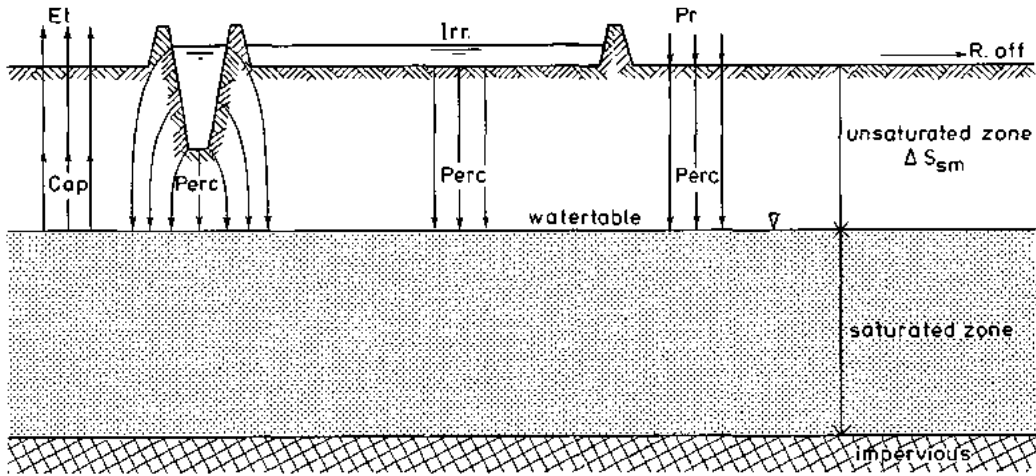

Fig. 2.33 Flow components for assessing a water balance of the unsaturated zone

Estimating unknown components

The water balance technique itself is a valuable tool for quantifying certain components of the equation that are otherwise difficult to determine. A water balance is commonly assessed for a certain period, which is chosen in such a way that all the values of the various components of the equation are known, with the exception of one. Under controlled conditions, as in lysimeters for example, where the quantities of rain, irrigation water, and water drained from the lysimeter have been measured, the unknown quantity of water lost by evapotranspiration can be calculated: $E_t = P_r + I_{rr} - D_r$.

When applying this approach, one must know the numerical values of the components with great precision, otherwise the result may be misleading; inaccuracies in one or more of the known quantities may exceed the magnitude of the unknown quantity. Inaccuracies in the major components strongly affect the value of a minor component; errors of a few hundred per cent are possible.

It is often possible to simplify the groundwater balance equation. If, for example, the period is chosen as the time between two irrigation applications, the soil water storage at the beginning and the end of the period is at field capacity. This means that the change in soil water storage over this period is zero and can thus be eliminated from the equation.

Another simplification is to choose a period without rain ($P_{rec} = 0$) or a period at the beginning and the end of which the watertable is at the same elevation so that there is no change in groundwater storage ($\Delta S_{grw} = 0$). One can also choose an appropriate area, for instance a portion of the aquifer where no surface inflow and outflow occurs ($Q_{per} = Q_{dr} = 0$) or where the watertable is deep ($Cap = 0$).

In an aquifer with a shallow watertable where the only discharge is by drainage to streams and water courses (Q_{dr}), where no surface water is imported or exported, and where the change in groundwater storage can be neglected because a long period of time is considered, the balance equation simplifies to:

$$R = \frac{Q_{dr}}{A} - (Pr - Et) \quad (2.20)$$

where

R = the net recharge of the aquifer

A = the horizontal surface area

and the other symbols are as defined earlier.

This equation shows the practical significance of the net subsurface inflow to the aquifer. The quantity RA represents the difference between the average amount of water drained by streams and water courses and the average supply $(Pr - Et)A$. Obviously, the net recharge (R) can be either positive or negative. Negative values of R indicate recharge areas, i.e. areas where the net supply $(Pr - Et)A$ exceeds the discharge (Q_{dr}) , and positive values indicate discharge areas where the opposite is true.

Estimating aquifer characteristics

The water balance technique can even be used to estimate averages of certain aquifer characteristics. Determining the hydraulic resistance of the confining layer covering a semi-confined aquifer, for instance, often poses a problem, because it would require several aquifer tests at appropriate places in the basin. If such tests cannot be made, the order of magnitude of this aquifer characteristic can be obtained by assessing a groundwater balance. The procedure is as follows. One selects a month, say a month in the rainy season during which the rainfall has been measured. In this month of rainy weather and cloudy skies, the evapotranspiration is so slight that, as a first approximation, it is neglected. Double piezometers, one set placed in the aquifer and one set in the covering layer, show a watertable rise in the covering layer. A soil survey has enabled a fair estimate of the specific yield of the covering layer to be made. The water level readings from the piezometers show a difference in head between the shallow and the deep piezometers. The average head difference for the month can be determined. If there is no inflow or outflow of surface water in the

area, nor any pumpage from wells, nor artificial recharge, the groundwater balance equation then reads:

$$Pr - \frac{h' - h}{c} = \Delta S_{grw} = \mu' \frac{\Delta h'}{\Delta t} \quad (2.21)$$

The hydraulic resistance, c , of the confining layer is the only unknown in this equation and can be solved from the equation. Uncertainty exists, of course, in the estimated value of μ' , which can be higher or lower than the assumed value. The calculations can therefore be repeated for, say, a value of μ' two times higher and two times lower than the value assumed. New values of c are then found and from them an average value can be calculated. If a negative value of c is found, the assumed factor of two was erroneous, and the calculations should be repeated for a lower value. In this way it is possible to find the maximum value that μ' can assume for given data on rainfall, head difference, and rise in watertable.

Another month can be selected, for example one in which there was no rainfall ($Pr = 0$). The evapotranspiration is estimated from climatological data. During the month a watertable rise in the covering layer was observed, and the water levels in the deep piezometers were, on the average, a given height above those of the shallow piezometers. The specific yield of the covering layer is not known but can be estimated from soil survey data. This information allows the order of magnitude of the hydraulic resistance of the covering layer to be determined.

$$Pr - Et + \frac{h - h'}{c} = \Delta S_{grw} = \mu' \frac{\Delta h'}{\Delta t} \quad (2.22)$$

The value of c can be solved from this equation, but it may be erroneous, because uncertainties exist in both the evapotranspiration and the specific yield. The effect of these uncertainties on the value of c should therefore be examined. Firstly a higher and a lower value of μ' is assumed, within the range that seems reasonable, e.g. two times higher and two times lower than had previously been assumed. New values of c are then found. Next, possible errors in the evapotranspiration are examined, for example by taking a higher and a lower value of Et . Finally, the calculations are

repeated on the assumption that errors in both evapotranspiration and specific yield occur simultaneously. This results in two values of c . The mean of these two values can be determined, although one must be aware that the real value of c can be a factor x higher or lower than the calculated value.

Final remarks

The water balance approach or any of the other above approximate methods of estimating aquifer characteristics should not be regarded as a substitute for the more accurate methods of aquifer tests or field experiments. Approximate methods are not appropriate in the study of local problems such as the planning of a new pumping station for drinking water supply. For such problems, whether being solved analytically or numerically, it is wise to conduct one or more aquifer tests to find reliable values for the aquifer characteristics.

Things are different when one is working in large groundwater basins, extending over hundreds or even thousands of square kilometres. In such basins one cannot conduct aquifer tests in unlimited numbers because the costs would be prohibitive. Less costly methods, approximating the aquifer's characteristics, are then a valuable addition to the more accurate methods. The experienced groundwater geologist, however, will know that even aquifer tests do not yield precise values, the reasons being the heterogeneity of the aquifer material and confining beds, the limited number of observation wells and/or piezometers, and the graphical methods frequently used to derive the aquifer characteristics. With only one or two observation wells or piezometers, the flow pattern around a pumped well cannot be properly analyzed, so the assumptions made as to the flow system provoked by the pumping are probably erroneous. Determining aquifer characteristics by graphical methods is not precise because more often than not, when trying to fit field data plots with standard curves, one finds that different matching positions are possible. Particularly sensitive in this respect is the value of the hydraulic resistance of a confining layer.

There is no justification in stressing the high accuracy of aquifer characteristics derived from aquifer tests unless the tests have been properly conducted, unless anomalies in the flow regime during the tests were not observed, and unless the assumptions underlying the formulas were satisfied. This ideal situation is rare indeed.

Recent developments in finding the best set of aquifer characteristics have been the introduction of various automatic and semi-automatic statistical and optimization techniques. The statistical techniques are based on an iterative trial-and-error procedure that attempts to improve an existing estimate of the characteristics. The optimization techniques try to achieve a detailed adjustment of the characteristics. Applying these techniques, one's primary aim is to use the computer to find a set of aquifer characteristics that give the best model response. The experienced user will know that more than one set of aquifer transmissivities will usually give equally good results. These techniques will frequently work and, in special situations, may be the only alternative left to the investigator. But the danger inherent in them is that the computer may come to be regarded as a substitute for field observations. For this reason we have emphasized the geomorphological and geological field work needed to arrive at reliable models. Estimates made without an understanding of the basin's geology and of the range of values that aquifer characteristics may assume in different parts of the basin will almost always be erroneous. On the other hand, once the geologist has formed his conclusions on the physical characteristics of the formations and structures controlling the flow of groundwater, he should not overlook the best possible check on the accuracy of his findings by testing them against an analysis of engineering measurements.

Groundwater basin modelling is, in essence, the art and science of applying various investigatory methods, checking their results against one another, and representing the complexity of nature in a simplified form that allows mathematical treatment, and all this within the constraints of morality and laws governing science.

3.1 General

The model that will be described in this book is largely based on the programming ideas of Tyson and Weber (1963) and also includes some of the ideas developed by Goodwill (see Dietrich and Goodwill 1972).

Incorporated in the model are the following features and restrictions:

- The aquifer is treated as a two-dimensional flow system;
- Both unsteady and steady state conditions can be simulated;
- Only one aquifer system can be modelled with one storage coefficient in vertical direction;
- The aquifer is bounded at the bottom by an impermeable layer;
- The upper boundary of the aquifer is an impermeable layer (confined aquifer), a slightly permeable layer (semi-confined layer), or the free watertable (phreatic or unconfined aquifer);
- Darcy's law (linear resistance to laminar flow) and Dupuit's assumptions (vertical flow can be neglected) are applicable in the aquifer;
- The aquifer has head-controlled, flow-controlled, and/or zero-flow boundaries; the first two may vary with time;
- For unconfined aquifers the transmissivity varies with time; the model adjusts the saturated thickness according to the calculated watertable elevation (non-linear conditions); only the hydraulic conductivity and the bottom of the aquifer must be prescribed. The same applies for the slightly permeable top layer of a semi-confined aquifer;

- In semi-confined aquifers horizontal flow in the top layer is neglected; the watertable in this layer may vary according to recharge and seepage rates or can be taken constant;
- Limits, in between which the watertable in the aquifer is allowed to vary, can be prescribed. If the watertable exceeds a certain limit, the model introduces an artificial flow rate that will keep the calculated watertable within that limit;
- The processes of the infiltration and percolation of rain and surface water and of capillary rise and evapotranspiration, taking place in the unsaturated zone of an aquifer (above the watertable), cannot be simulated. This means that the net recharge to the aquifer must be calculated manually and prescribed to the model.
- The model cannot simulate spatial and time variations of groundwater quality.

3.2 Physical background

The model is based on the two well-known equations: Darcy's law and the equation of conservation of mass. The combination of these two equations results in a partial differential equation for unsteady flow:

$$\frac{\partial}{\partial x} (KD \frac{\partial h}{\partial x}) + \frac{\partial}{\partial y} (KD \frac{\partial h}{\partial y}) = - N \quad (3.1)$$

where

$K(x,y)$ = hydraulic conductivity of the aquifer for horizontal flow
($L T^{-1}$)

$D(x,y,t)$ = saturated thickness of the aquifer at time t (L)

$h(x,y,t)$ = hydraulic head in the aquifer at time t (L)

$N(x,y,t)$ = source or sink term at time t ($L T^{-1}$)

The left-hand side of Eq. 3.1 represents the horizontal flow in the aquifer, the right-hand side the vertical flow. Vertical flow (N) consists of different flow components, depending on the type of aquifer.

For *unconfined aquifers* N is the sum of three terms:

$$N = R - P - \mu \frac{\partial h}{\partial t} \quad (3.2)$$

where

$R(x,y,t)$ = the net rate of recharge ($L T^{-1}$)

$P(x,y,t)$ = the net rate of abstraction ($L T^{-1}$)

$\mu(x,y)$ = specific yield of the aquifer (dimensionless)

$h(x,y)$ = hydraulic head in the aquifer (L)

t = time (T)

The term $\mu \partial h/\partial t$ is related to the movement of the free watertable in case of unsteady flow. When the watertable moves downwards or upwards, water is released from or taken into storage, respectively. The specific yield μ is defined as the volume of water released or stored per unit surface area of the aquifer per unit change in the component of head normal to that surface. In practice it may be considered to equal the effective porosity or drainable pore space because in unconfined aquifers the effects of elasticity of aquifer material and fluid are generally so small that they can be neglected. It will be assumed that the values of μ for upward and downward movement of the watertable are equal and that the gravity yield is instantaneous. This is the classical, simple assumption usually made.

In unconfined aquifers the saturated thickness D is not a constant, but is a function of the position of the free watertable at time t .

For *confined aquifers* N is the sum of only two terms:

$$N = -P - S \frac{\partial h}{\partial t} \quad (3.3)$$

where

S = the storage coefficient of the aquifer (dimensionless)

The impermeable covering layer allows neither recharge from percolation nor the formation of a free watertable in this layer. The storage coefficient S

in Eq. 3.3 is therefore not related to the effective porosity or drainable pore space, but to the elasticity of the grain material and that of the water. For confined aquifers S is called the storage coefficient and is defined in the same way as the specific yield for unconfined aquifers (Chap. 2 Sect. 2.7). The saturated thickness D of confined aquifers is constant.

For *semi-confined aquifers* the flow through the covering, slightly permeable layer has to be considered. The physical characteristics of this layer will be indicated with primes to distinguish them from the corresponding characteristics of the underlying aquifer. It will be assumed that the thickness D' of the water body in the covering layer is less than the thickness D of the aquifer, and moreover, that its hydraulic conductivity K' is low compared with the hydraulic conductivity K of the aquifer, though it is not zero. Consequently, horizontal flow through the covering layer can be neglected. This assumption can be regarded as an exact formulation when the covering layer consists of anisotropic material with a hydraulic conductivity K' in vertical direction and zero hydraulic conductivity in all horizontal directions.

For *semi-confined aquifers* there are two differential equations, one for the aquifer and the other for the covering layer. For the aquifer, N is the sum of three terms:

$$N = -P - S \frac{\partial h}{\partial t} + \frac{K'}{D'} (h' - h) \quad (3.4)$$

where

K' = the covering layer's hydraulic conductivity for vertical flow
(L T⁻¹)

D' = saturated thickness of the covering layer (L)

h' = hydraulic head in the covering layer (L)

and the other symbols as defined earlier.

Unlike confined aquifers, semi-confined aquifers are given one additional term representing the vertical flow through the covering layer. This flow is caused by the head difference between the water in the covering layer

and that in the underlying aquifer. The saturated thickness D of the aquifer is constant.

For the covering layer there is also a one-dimensional differential equation. Since both the water received from percolation and that released by the falling watertable percolate through the covering layer before reaching the aquifer, the following equation applies:

$$R - \mu' \frac{\partial h}{\partial t} = \frac{K'}{D'} (h' - h) \quad (3.5)$$

where

μ' = specific yield of the covering layer (dimensionless)

We shall assume that the covering layer has a free watertable, so that its saturated thickness D' is not constant but may vary with time. Owing to its low permeability we also assume that no pumping will occur in this layer. Since Eq. 3.1 cannot be solved explicitly, a numerical approach can be followed, allowing an approximate solution to be obtained.

3.3 Numerical approaches

The solution of a partial differential equation can be obtained by using a finite differences method. This method requires that space be divided into small but finite intervals. The sub-areas thus formed are called nodal areas, since they each have a node which is used to connect each area mathematically with its neighbours. It is assumed that all recharge and abstraction in a nodal area occur at the node; in other words, each node is considered to be representative of its nodal area. To each node a certain storage coefficient or specific yield is assigned, which is constant and representative for that nodal area. A certain hydraulic conductivity is assigned to the boundaries between nodal areas, thus allowing directional anisotropic conditions.

An approximate solution to Eq. 3.1 can be obtained by replacing it with an equivalent system of difference-differential equations, the simultaneous

solution of which gives the function of h at a finite number of nodes. To illustrate this we shall elaborate the difference-differential equation for a semi-confined aquifer. For the two other types of aquifers, analogous difference-differential equations can be derived.

For an arbitrary node b of a nodal network (Fig. 3.1) the equation for a semi-confined aquifer is obtained by combining Eqs. 3.1 and 3.4. This yields:

$$\sum_i (h_i - h_b) \frac{W_{i,b} K_{i,b} D_{i,b}}{L_{i,b}} = A_b P_b + A_b S_b \frac{dh_b}{dt} - \frac{A_b K'_b}{D'_b} (h'_b - h_b) \quad (3.6)$$

where

- $W_{i,b}$ = length of side between nodes i and b (L)
 - $L_{i,b}$ = distance between nodes i and b (L)
 - A_b = area associated with node b (L^2),
- and the other symbols as defined earlier.

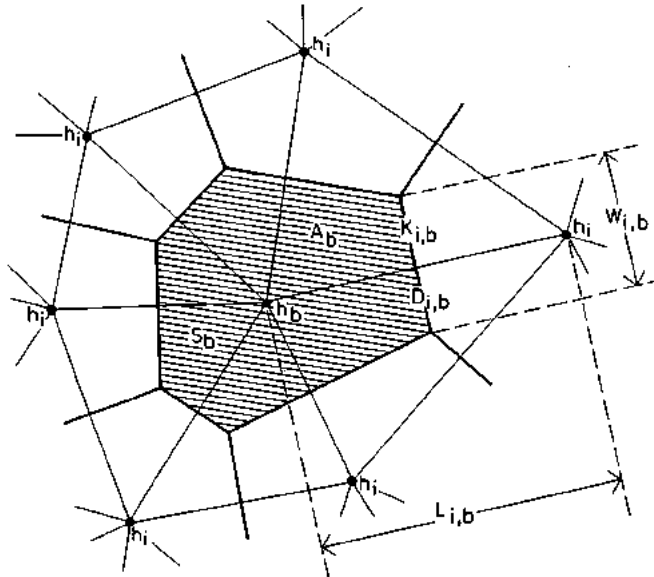

Fig. 3.1 Nodal geometry

Since the watertables at the nodes change with time owing to changes in recharge and abstraction, the model also requires a discretization of time. Hence a number of successive time intervals have to be chosen. For each time interval the watertables are computed and the calculation is repeated at successive times. Discretizing the time period requires that all Eqs. 3.6 be replaced by:

$$\sum_i \left[h_i(t+1) - h_b(t+1) \right] \frac{W_{i,b} K_{i,b} D_{i,b}}{L_{i,b}} = A_b P_b(t+1) + \frac{A_b S_b}{\Delta t} \left[h_b(t+1) - h_b(t) \right] - \frac{A_b K'_b}{D'_b} \left[h'_b(t+1) - h_b(t+1) \right] \quad (3.7)$$

with $t + 1 = t + \Delta t$

All Eqs. 3.7 are solved by an implicit numerical integration technique (Richtmeyer and Morton 1967). This method of integration has the advantage that the magnitude of the time step Δt does not depend on a stability criterion.

The calculation procedure is as follows: Initial watertable elevations are prescribed to all the nodes. At the end of the first time step, Δt , the components of the water balance of all Eqs. 3.7 are calculated for each nodal area according to the given set of variables $K_{i,b}$, $D_{i,b}$, S_b , $L_{i,b}$, $W_{i,b}$, the initial watertable elevations, and the recharge and/or abstraction rates during the actual time step. This results in a change in the water balance for each nodal area. All flows are balanced at each node by setting their sum equal to a residual term. The new watertable elevations at each node are then adjusted by the magnitude of these residuals, as follows:

$$h_b(t+1) = h_b(t) + \frac{\text{residual for nodal area } b}{\sum_i \frac{W_{i,b} K_{i,b} D_{i,b}}{L_{i,b}} + \frac{A_b S_b}{\Delta t} + \frac{A_b K'_b}{D'_b}} \quad (3.8)$$

These changes in watertable elevations, however, influence the lateral groundwater flow from one nodal area to another. If the aquifer is semi-confined, the changes also influence the vertical flow through the confining layer. This means that laborious iterative calculations are required to find the proper water balances for each nodal area and their corresponding watertable elevations. After each iteration the sum of all the residual values of the water balances over all the nodal areas is calculated and this sum - which in fact must be zero - is compared with a threshold value. This value must be prescribed and is specified as the maximum tolerable error in the regional water balance. The iterative procedure within the first time step is repeated as many times as are needed to reduce the sum of all the residual values to a value that is equal to or less than the prescribed threshold value. The smaller the threshold value chosen, the better the results will be, but the more iterations will be required in each time step. The watertable elevations at the end of the first time step serve as the starting conditions for the next time step, after which the whole process is repeated.

The method of solving Eqs. 3.7 simultaneously, as outlined above, is essentially that of Gauss-Seidel (Ralston 1961). Some of the principles used in our model can also be found in Thomas (1973).

Another way of solving Eqs. 3.7 is by using an elimination method, by which the equations are solved directly instead of iteratively.

Rearranging the terms of Eqs. 3.7 yields:

$$\begin{aligned}
 -h_b(t+1) \left[\sum_i \frac{W_{i,b} K_{i,b} D_{i,b}}{L_{i,b}} + \frac{A_b S_b}{\Delta t} + \frac{A_b K'_b}{D'_b} \right] + \sum_i h_i(t+1) \frac{W_{i,b} K_{i,b} D_{i,b}}{L_{i,b}} = \\
 = A_b P_b(t+1) - \frac{A_b S_b}{\Delta t} h_b(t) - \frac{A_b K'_b}{D'_b} h'_b(t+1) \quad (3.9)
 \end{aligned}$$

Assuming that the free watertable in the covering confining layer remains constant, the right-hand side of Eqs. 3.9 has a known value at time $t + 1$. The left-hand side of the equation represents the unknown value of h_b , the unknown values of h_i of the surrounding nodes, and the known values of

their coefficients, provided that the values of $D_{i,b}$ are kept constant during each time step. If there are n nodes in the network, there are n Eqs. 3.9 with n unknown values of h_b . By introducing new variables for the known values, Eqs. 3.9 become:

$$\begin{aligned}
 a_{11}h_1 + \sum_j a_{1j}h_{1j} &= f_1 \\
 a_{bb}h_b + \sum_j a_{bj}h_{bj} &= f_b \\
 a_{nn}h_n + \sum_j a_{nj}h_{nj} &= f_n
 \end{aligned}
 \tag{3.10}$$

In matrix notation, Eq. 3.10 can be written as

$$A h = f$$

where

$$A \equiv \begin{bmatrix} a_{11} & a_{1b} & a_{1n} \\ a_{b1} & a_{bb} & a_{bn} \\ a_{n1} & a_{nb} & a_{nn} \end{bmatrix}, \quad h \equiv \begin{bmatrix} h_1 \\ h_b \\ h_n \end{bmatrix}, \quad f \equiv \begin{bmatrix} f_1 \\ f_b \\ f_n \end{bmatrix}
 \tag{3.11}$$

In Eq. 3.11 the diagonal of the coefficient matrix A is formed by the coefficients of the unknown values of h_b . To solve the linear system of algebraic equations (3.11) the Gauss elimination method is used (McCracken and Dorn 1964). Basically it is the elementary procedure by which the "first" equation is used to eliminate the first "variable" from the last $n - 1$ equations. Then the new "second" equation is used to eliminate the "second" variable from the last $n - 2$ equations, and so on. If $n - 1$ eliminations are performed, the resulting linear system, which is equivalent to the original system, is triangular and the unknown values of h_b can easily be solved by back substitution. In the program a modification of the Gaussian elimination method, known as the Gauss-Jordan approach, has been used. In this

approach the back substitution is integrated in the elimination procedure (Isaacson and Keller 1966).

The advantage of this method is that the solution is exact within the accuracy of the computer used. A disadvantage is that the method requires substantially more computer memory than the iteration method. Mutually exchangeable computer programs are presented for both methods. The user can choose which method best suits his purpose.

3.4 Design of nodal network

To discretize a groundwater basin into nodal areas, a network of rectangles, squares, or polygons is superimposed upon it. It is impossible to give any hard and fast rules on what network to apply and how to design it. Because of different geological and hydrogeological conditions, a network that is appropriate in one basin will be inappropriate in another; similarly, a network appropriate for one problem will be inappropriate for another. Nevertheless, there is a certain general procedure to be followed in designing a network and this will now be explained.

In designing a nodal network, one begins by considering the following factors:

- (a) the type of problems to be solved;
- (b) the required accuracy of the results;
- (c) the homogeneity or heterogeneity of the aquifer;
- (d) the availability of data;
- (e) the shape of the boundaries;
- (f) the number of nodes

(a) The problem to be solved can be regional or local, reconnaissance or detailed, simple or complex. A reconnaissance study of a large groundwater basin will require a network with a large mesh; a detailed local problem will require a network with a small mesh.

(b) The accuracy of the results generated by the computer largely depends on the mesh size. Where accurate results are required and relatively large

changes of the watertable occur (or may be expected), the mesh size must be small; where no such accuracy is required and only minor watertable changes occur (or may be expected), the mesh sizes can be larger.

(c) Few aquifers are homogeneous over their whole lateral extent. In aquifers that show a clear transition from unconfined to partly confined or confined, the network should be adapted accordingly.

(d) In large groundwater basins, data may not be available with the same consistency in all parts of the basin. In remote parts of it, data are likely to be scarce. If so, it makes no sense to use small mesh sizes there. Small mesh sizes require numerous data, but since these are not available, average values or estimates would have to be substituted; the computer results would then suggest an accuracy that does not exist.

(e) If the groundwater basin to be modelled is bounded by straight lines that are parallel to the coordinate axes of a regular network (squares or rectangles), the representation of the conditions at the boundaries presents no problem. Few groundwater basins, however, (or flow domains of practical interest) have straight boundaries. Usually, some of the boundaries, or even all of them, are irregular or curved. The use of a regular network then poses problems because the boundaries do not coincide everywhere with the nodes of the network. The modifications that must be made to represent such irregular and curved boundaries will be explained later in this section.

(f) On the number of nodes required to model an aquifer, opinions differ. Rushton and Redshaw (1979) recommend that between 500 and 2000 nodes be used. When one is modelling for the first time, however, it is better to follow the advice of Thomas (1973) and restrict the number of nodes to 10 or 15. As one gains experience, one can use networks with more nodes. The available funds may also restrict the number of nodes.

Having given due consideration to these factors one will begin to have some idea of the network that will be needed to suit one's particular groundwater basin or particular problem. The next step is to take a map of the groundwater basin, or problem area, and mark on it the external boundaries.

It should be specified whether these boundaries are zero-flow, head-controlled, or flow-controlled. If any internal boundaries exist (a drainage or a barrier boundary), they should also be marked on the map (see Chap. 2 Sect. 2.5).

If the basin contains more than one type of aquifer, these should be delineated on the map. For example, it must be shown where an unconfined aquifer passes into a semi-confined or confined aquifer.

It would be ideal if each sub-area of the network (square, rectangle, or polygon) represented a homogeneous hydrological unit. Inside each such unit the aquifer would react to recharge and discharge conditions in the same way everywhere. This would greatly improve the reliability of the nodal watertable elevations generated by the computer. Few aquifers, however, are homogeneous or have a constant thickness everywhere. Nevertheless, one should study the geology, aquifer characteristics, and especially well hydrographs because these will reveal areas that can be regarded, at least to some extent, as hydrological units. By adjusting the network to these units, one can approximate the ideal situation.

A watertable-contour map is a basic map in the design of a nodal network. It shows the magnitude of the hydraulic gradient and its spatial variations. Steep gradients occur in zones of concentrated recharge and discharge, or near faults that form a barrier to groundwater flow. Zones of steep hydraulic gradients require fine meshes, if the watertable elevations generated by the computer are to have any meaning (Fig. 3.2).

A regular network is constructed by applying the Thiessen method. A series of parallel lines are drawn perpendicular to another series of parallel lines. The points of intersection, which are the control points of the flow region, are the nodes. Perpendicular bisectors of the lines connecting the nodes are then drawn to obtain the squares or rectangles.

Special attention must be given to curved boundaries not passing through the nodes of a regular network. If there are great distances between the boundary and the adjacent nodes, special difference equations would have to be developed for points near the boundary (Remson et al. 1971) and adjustments would have to be made in the computer programs. A user can only make these adjustments, however, if he is experienced in computer programming,

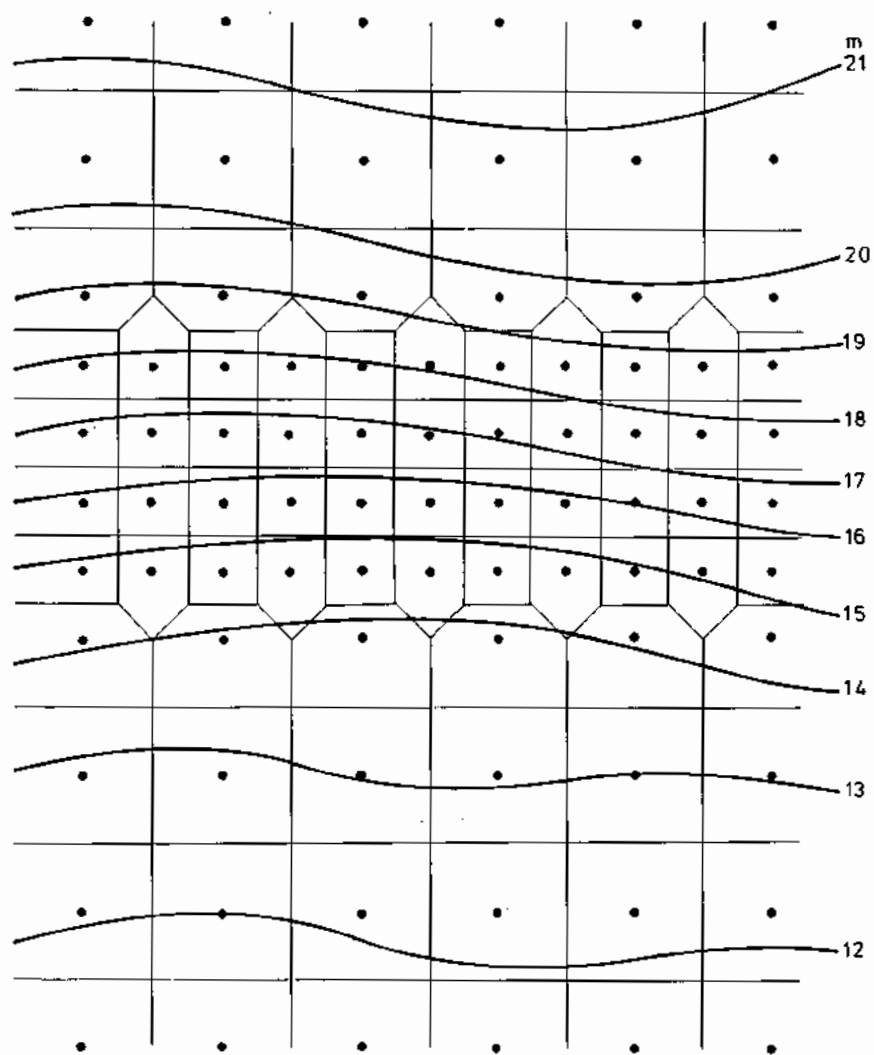

Fig. 3.2 Graded network superimposed on a watertable-contour map showing different hydraulic gradients. In the area with steep gradients a smaller mesh size is used than in areas with slight gradients

but as we assumed that our readers have no such experience, they will be unable to make these adjustments.

For this reason another approach is followed. It consists of approximating the true curved boundary with a nearby curve that passes through the nodes of the grid ($\Delta x = \Delta y$) or the network of rectangles ($\Delta x \neq \Delta y$). If the boundary is strongly curved, small mesh sizes are required to approximate it. Figure 3.3 shows a grid-point approximation of a curved boundary.

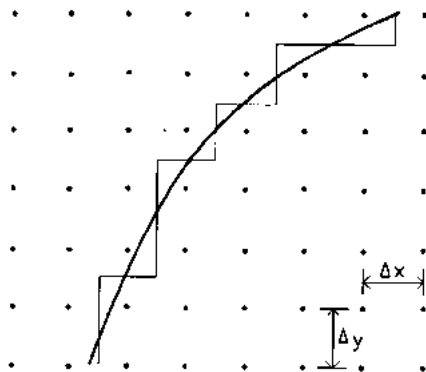

Fig. 3.3 Typical grid-point approximation of a curved boundary

The error introduced by such approximations is negligible provided the mesh size is small enough. It should be noted, however, that appreciable errors can be introduced if the boundary is strongly curved and if an accurate solution to the flow problem near such a boundary is desired.

With a regular network the position of observation wells will never coincide with the position of the nodes. This means that the historic watertable elevations required for the model cannot simply be read from the records of these wells. Instead, the required watertable elevations of the nodes must be determined by interpolation from watertable-contour maps on which the network is superimposed.

With an irregular network, much of this tedious interpolation work can be avoided. An irregular network is also constructed by the Thiessen method. One selects appropriate existing watertable observation wells and constructs a system of triangles whose internal angles must all be less than 90° . Perpendicular bisectors are then drawn to all the sides of the triangles to obtain polygons. As the nodes of the polygons represent observation wells, their data can be read from the records, provided that the watertable elevations are representative of the polygonal area.

It will not always be possible to follow this procedure because the number and spacing of the observations wells will not always be appropriate. Where fine meshes are required, for instance, the well spacings may be too large. Under these circumstances, a number of arbitrary nodes must be selected to obtain the required mesh. The watertable data of the arbitrary nodes then has to be found by interpolation from the watertable-contour map.

The polygons can be made smaller or larger to approximate an irregular boundary by replacing it with straight line segments. A disadvantage of an irregular network is that the speed of convergence of the solution is less than with a regular network; this means that more iterations are needed in the calculation process. For this reason, Rushton and Redshaw (1979) recommend that a regular grid be used wherever possible.

Figure 3.4 shows two examples of networks. Note that in addition to their internal nodes, these networks also have external nodes; these are primarily needed to construct the network near the boundaries. Such boundaries can be either head-controlled (the head at the external nodes opposite the boundary is known) or flow-controlled (the head at the external nodes is unknown, but the flow is known or can be estimated).

The construction of a nodal network is often a matter of trial and error. Several trials, followed by adjustments, may be needed to obtain a network that suits the problem and avoids large numbers of nodes for which the necessary data are missing or for which precise results are not required.

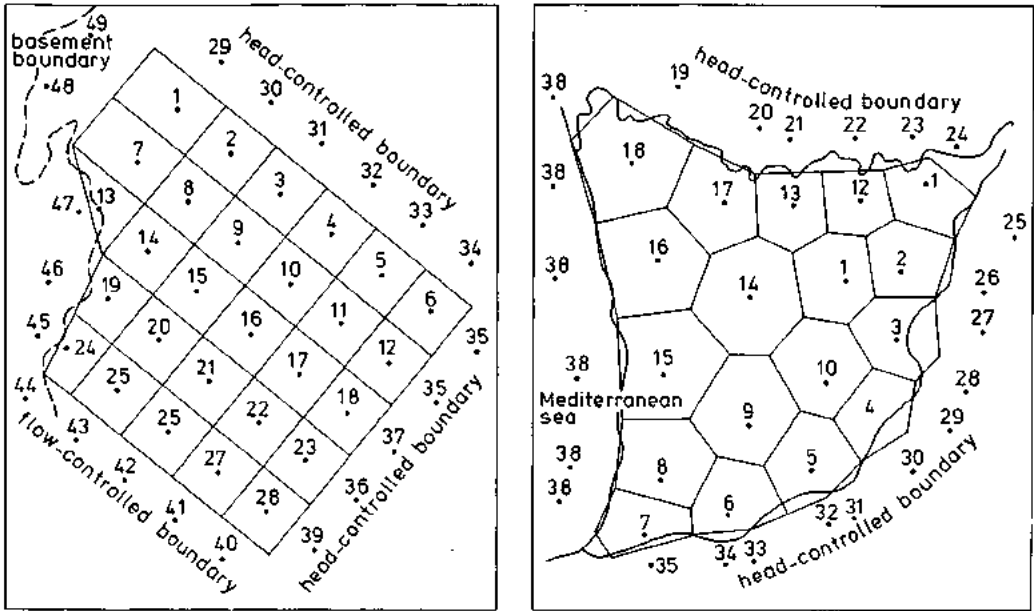

Fig. 3.4 Examples of nodal networks (Thomas 1973)

3.5 Data required for the model

3.5.1 Nodal coordinates

To enable the computer to calculate the different flow rates across the boundaries of the nodal areas and the changes in storage inside these areas, data must be provided on the length of flow path between adjacent nodes, on the width of cross-sectional area of flow, and on the surface area of each nodal area. These tedious measurements and calculations can be performed by the computer. This requires the use of a Cartesian coordinate system, which is drawn on the map of the nodal network. The coordinate values of all the nodes must be read and presented in a table.

3.5.2 Hydraulic conductivity

To calculate the groundwater flow across the boundaries of the nodal areas, the weighted mean hydraulic conductivity values midway between all the nodes have to be determined. This is done by superimposing the network map on the hydraulic conductivity map, which shows lines of equal mean hydraulic conductivity. The hydraulic conductivity of the sides of each nodal area is then found by interpolation or, if two or more isoperms cross a side, the weighted mean hydraulic conductivity is calculated. The results are presented on a separate, clean network map.

It should be noted that, unlike confined and semi-confined aquifers, an unconfined aquifer is only partly saturated. The mean hydraulic conductivity of such an aquifer usually refers to the saturated part only. If the aquifer is thick and its watertable shallow, this value can be used without any great errors. If the watertable is deep, however, the mean hydraulic conductivity should be calculated for the whole aquifer, both its saturated and unsaturated parts. In practice the weighted mean hydraulic conductivity of the unsaturated part is estimated from well logs, as was discussed in Chap. 2 Sect. 2.7.

If the aquifer is semi-confined, values of the hydraulic conductivity of the slightly permeable covering layer are also needed. Since the flow through this layer is vertical (either upward or downward), the mean weighted hydraulic conductivity for vertical flow of each nodal area should be calculated and the results presented on a separate, clean network map.

3.5.3 Aquifer thickness

The model requires that values of the aquifer thickness be supplied, or more specifically, it requires these values midway between adjacent nodes. Since the upper and lower limits of the aquifer may vary throughout the basin and also the types of aquifer may differ, the following procedure is used.

Unconfined aquifers are only partly saturated. To find the saturated thickness, the network is superimposed on a contour map of the impermeable base and a weighted mean bottom level elevation for each nodal area (BL-value) is determined. The results are plotted on a separate, clean network map.

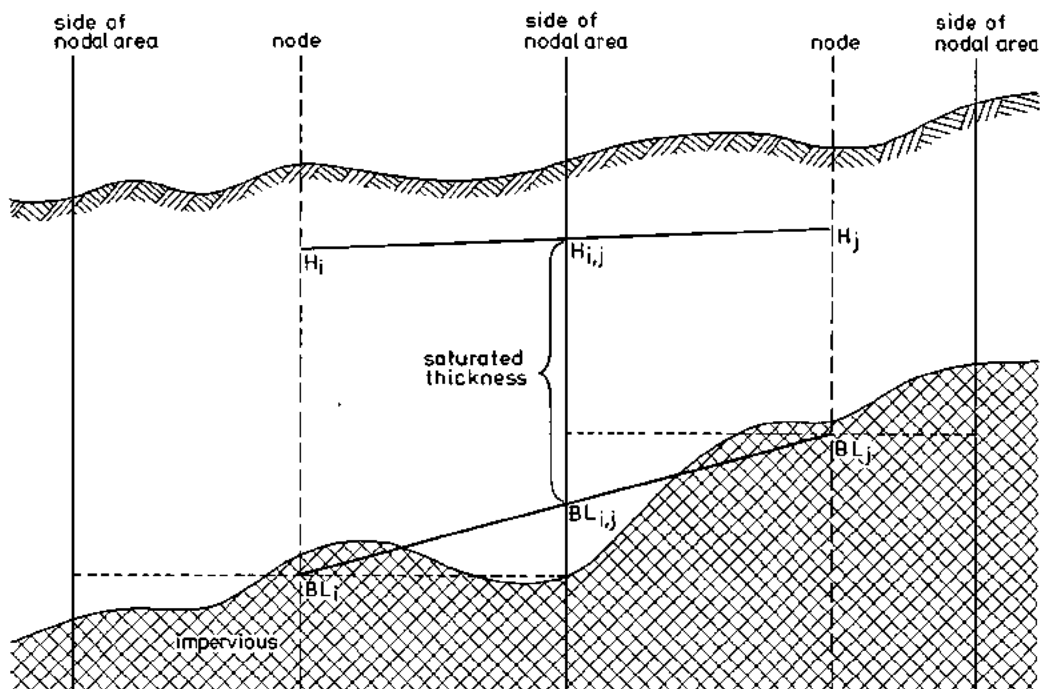

Fig. 3.5 Unconfined aquifer. Determination of the arithmetic mean water-table elevation (equal to saturated aquifer thickness) midway between two adjacent nodes. BL_i is weighted mean elevation of aquifer bottom at node i

For an unconfined aquifer, the computer is programmed to calculate the arithmetic mean elevation of the aquifer bottom between two adjacent nodes (Fig. 3.5). The $BL_{i,j}$ value in the figure is assumed to represent the average aquifer bottom elevation along the side shared by two adjoining nodal areas. At each iteration the computer calculates a new watertable elevation for each node (in Fig. 3.5: H_i and H_j). For two adjacent nodes

the arithmetic mean of the watertable elevations is then calculated, and it is assumed that this value represents the average watertable elevation along the adjoining side of the two nodal areas. The computer then calculates the difference between the average watertable elevation and the average aquifer bottom elevation midway between the two nodes. The result represents the saturated thickness along the side of the two nodal areas.

Confined aquifers are fully saturated. To find the weighted mean aquifer thickness for each nodal area, the network is superimposed on the isopach map of the aquifer, which shows lines of equal thickness. The weighted mean aquifer thickness can then be determined at each node (Fig. 3.6) and plotted on a separate, clean network map.

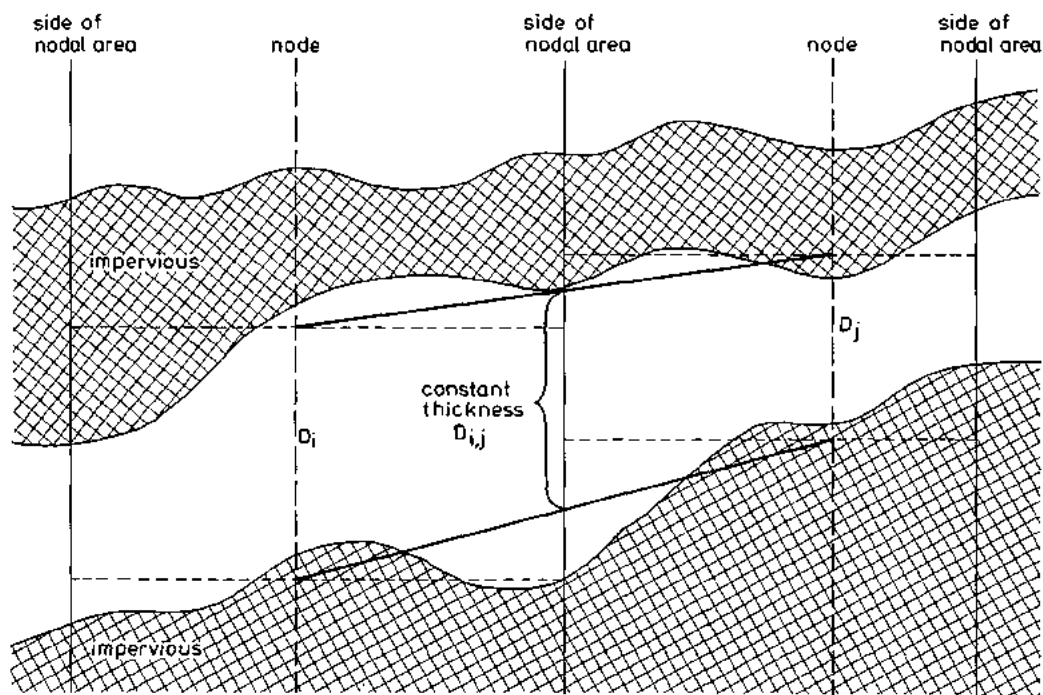

Fig. 3.6 Confined aquifer. Determination of the constant aquifer thickness midway between two adjacent nodes

The computer calculates the arithmetic mean aquifer thickness midway between two adjacent nodes and this value is taken as being representative of the average thickness along the side shared by the two nodal areas.

Semi-confined aquifers are also fully saturated. Their constant thickness along the sides of adjoining nodal areas is determined in the same way as for confined aquifers. A semi-confined aquifer, however, has a confining covering layer with a free watertable that changes with time. The saturated thickness of the underlying aquifer thus remains constant, but that of the confining covering layer varies. To find the weighted mean elevation of the lower boundary of the confining layer for each nodal area, the network is superimposed on the contour map of the impermeable base and on the isopach map of the aquifer. The weighted bottom level elevation (BL_i -value) and the weighted mean aquifer thickness (D_i -value) can then be determined and plotted on two separate, clean network maps. The computer calculates the weighted mean elevation of the lower boundary of the confining layer by taking the sum of the BL_i and D_i values at each node (Fig. 3.7).

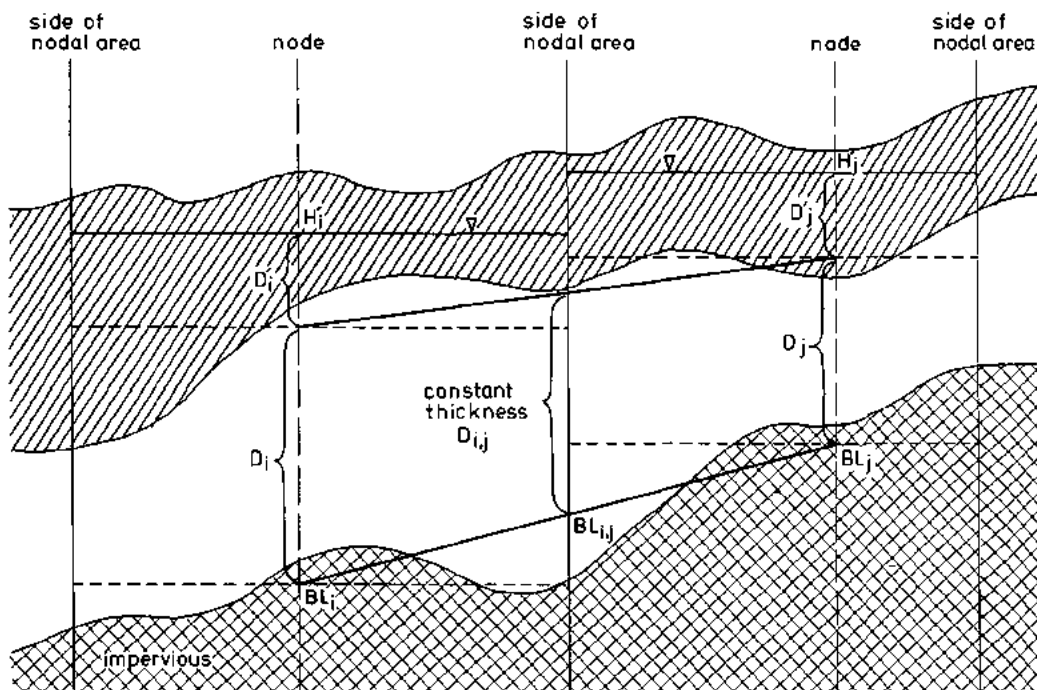

Fig. 3.7 Semi-confined aquifer. Determination of the constant thickness of the aquifer and of the saturated thickness of the confining covering layer midway between two adjacent nodes

At each iteration the computer calculates the new nodal watertable elevation in the confining covering layer. It then calculates the difference in elevation between this watertable and the lower boundary of the confining covering layer. This difference represents the saturated thickness of the covering layer for the time step under consideration.

Besides the information on the saturated thickness of the aquifer, the computer also requires information on the elevation of the land surface because all data on elevations - watertable elevations included - are related to a reference datum. The elevation of the land surface is found by superimposing the network on a topographical map showing contour lines of the land surface. The weighted mean land surface elevation of each nodal area is determined and the results are plotted on a separate, clean network map.

Note: Although the mean bottom level elevation (BL_1) is not required for the calculation of the saturated thickness of confined aquifers, it is nevertheless prescribed because in all aquifer types the lower aquifer boundaries serve as a control level below which the watertable cannot fall.

3.5.4 Specific yield and storage coefficient

For *unconfined aquifers* the calculation of any changes in storage of groundwater requires representative values of the aquifer's specific yield in each nodal area. These values can be found by superimposing the network on a map showing lines of equal specific yield and determining a weighted mean specific yield for each nodal area. The results are plotted on a separate, clean network map.

Note: that for unconfined aquifers the specific-yield map should refer to the zone in which the watertable fluctuates or is expected to fluctuate in the future. If the groundwater in the basin is to be pumped by wells or if surface water irrigation is to be introduced, the watertable may fall far below or rise far above its initial level. We therefore recommend that the weighted mean specific yield at each control point be determined from the

land surface to some 10 to 20 m below the deepest level to which the watertable drops under natural conditions. In areas with a relatively deep watertable, the weighted mean specific yield at each control point (wells, bores) should be determined for both the unsaturated zone and (part of) the saturated zone (Chap. 2 Sect. 2.7).

Modelling a *confined aquifer* requires a weighted mean storage coefficient for each nodal area. The same applies for a *semi-confined aquifer*; in addition, if the free watertable in its overlying confining layer changes with time, a weighted mean specific yield of this layer should be determined. Hence, for a semi-confined aquifer, two maps must be prepared: a storage coefficient map of the aquifer and a specific yield map of the overlying confining layer. To determine representative values of these parameters, one follows the same procedure as outlined above.

3.5.5 Hydraulic head

The calculation of the groundwater flow from one nodal area to another requires representative data on the hydraulic head in all the nodes of the network. Actually, for this calculation, only the initial hydraulic heads are needed. These can be found by superimposing the network on the watertable-contour map prepared for $t = 0$, i.e. the beginning of the historical period for which the calculations will be made. A representative hydraulic head is then determined for each node by interpolation and the values are plotted on a separate clean network map. If the node of a particular nodal area lies eccentric and if several watertable-contour lines pass through the nodal area, one may have to choose a head that is more representative of the area than the one of the actual node.

"History matching" is used to calibrate the model. This means that computed nodal hydraulic heads are compared with observed nodal hydraulic heads. To make such a comparison, one needs not only the initial nodal heads, but also the consecutive observed nodal heads for the whole calculation period. If this period is, say, a year, one can prepare monthly hydraulic heads, using the same procedure as outlined above.

Modelling a semi-confined aquifer requires initial nodal hydraulic heads, not only for the aquifer, but also for the overlying confining layer. So, for $t = 0$, two watertable-contour maps must be compiled: one for the aquifer and the other for the confining layer. The procedure of finding representative initial nodal heads for the two layers is the same as outlined above.

3.5.6 Net recharge

Net recharge data for all the nodal areas must be prepared. The net recharge is the algebraic sum of the following external flows: rainfall, evapotranspiration, surface runoff, seepage from watercourses, seepage to watercourses, irrigation losses, capillary rise from shallow watertables, abstraction by pumped wells, subsurface flow across flow-controlled boundaries, and artificial recharge, if any. Obviously, not all of these flows will occur everywhere and at the same time in a basin. For this reason, in our computer programs we have not allocated a specific variable to each of these flows; instead, we have divided them into two categories: external flows that are measured or calculated as a *depth* per time (e.g. rainfall and evapotranspiration) and external flows that are measured or calculated as a *volume* per time (e.g. abstraction by pumped wells and subsurface flow across a flow-controlled boundary). To each of these categories, we have allocated one variable: RECH(K) to the first and FLWCON(K) to the second. The values of these variables thus represent the algebraic sum of a number of external flows. We admit that this can be a disadvantage but it allows us to keep the model simple so that it can be run on small computers.

Note: Nodal net recharge values can only be prepared after the unit time for which the model is to be developed has been chosen (Chap. 4 Sect. 2.1). If that unit time is, say, one month, the two sets of monthly net recharge values for each nodal area must be prepared for the entire historical period being modelled.

Usually the individual components of these two lump terms are not known precisely. For instance, the stream flow entering and leaving a nodal area

is not known, and neither is the irrigation water supplied to a nodal area. Irrigation water losses in the water distribution system and on the fields are seldom known per nodal area. At best, only an estimate of these components can be made, based on whatever information is available.

For the external flows measured or calculated as a depth per time, the nodal network is superimposed consecutively on maps showing these flow rates (Chap. 2 Sect. 3). Each flow rate is then estimated in each nodal area and combined into one single value for each nodal area. These values are brought together in a table and expressed as a depth per time. The computer is programmed to multiply each value of RECH(K) by the area of each nodal area to obtain a volume rate of flow per time.

For the external flows measured or calculated as a volume per time, the nodal network is superimposed on maps showing these flow rates (Chap. 2 Sect. 3). Each flow rate is then estimated in each nodal area and combined into one single value for each nodal area. Finally, all these values are brought together in another table and expressed as a volume per time.

4 PROGRAM DETAILS

4.1 Package description

All computer programs consist of a source program, in which the calculation processes are recorded, and a data set, which contains the actual data needed to perform the calculations.

To make our model suitable to be run on even small computers, which would otherwise not have sufficient memory capacity to cope, we have decomposed our computer program into four parts. These four parts together form our "Standard Groundwater Model Program" (SMGP), which consists of:

- SGMP 1 + Data Set I (reading of input data/nodal network)
- SMGP 2 + Data Set II (calculation: iteration technique)
- SGMP 3^a + Data Set III (print-out of results)
- SGMP 3^b + Data Set IV (plot-out of results).

In principle, this package can be used for either regional or local groundwater flow studies. For certain specific conditions, however, two optional programs are available:

- OPRO 1 + Data Set V (which replaces SGMP 1 + Data Set I): (calculation of input data/regular network)
- OPRO 2 (which replaces SGMP 2): (calculation: elimination technique).

OPRO 1 has been specially developed for use in local groundwater flow studies (e.g. aquifer tests) in aquifers that are assumed to be homogeneous. Such studies require far more accurate watertable calculations than

regional studies and consequently a dense network with a great number of nodes. For these studies, it is preferable to use a regular network of rectangles or squares rather than an irregular network. Although, in principle, SGMP 1 can also be used for a regular network, the resulting input data handling is time-consuming; the use of OPRO 1 overcomes this problem. When it is desired to run OPRO 1, SGMP 1 and Data Set I are removed from the package and OPRO 1 and Data Set V are inserted in their place; the other source programs and data sets remain the same.

OPRO 2 replaces the iteration technique of SGMP 2 with an elimination technique. In regional studies, when the area includes semi-confined and/or confined aquifers, many iterations may be needed to get accurate results; the same applies in local studies when recharge or abstraction rates are high in relation to the size of the nodal areas. By using an elimination technique in such situations, one can avoid numerous iterations without endangering the accuracy of the results. Admittedly, an elimination technique consumes far more memory, but it can mean great savings in computer time. OPRO 2 uses the same data set as SGMP 2: Data Set II. When it is desired to use an elimination technique, SGMP 2 is removed from the package and is replaced by OPRO 2; the other source programs and data sets remain the same.

The user should be aware that when he runs OPRO 2, the following additional restrictions apply:

- If the aquifer is semi-confined, the watertable in the confining layer is *fixed* at the initial input level.
- Limits for the fluctuations of the groundwater level cannot be prescribed for the upper and lower boundary of the aquifer system; the program will thus not interfere to keep the groundwater levels within limits. The calculated water levels must therefore be checked in this respect.
- For unconfined aquifers the elimination technique introduces an error in the sense that the variable saturated thickness of such aquifers is not correctly simulated. Because this technique is a direct one, it means that for a certain time step the program uses the saturated thickness values as they have been calculated for the previous time step.

Irrespective of whether the optional programs or SGMP 1 or SGMP 2 are run, one can choose to have the results of the calculations either printed out with SGMP 3^a or plotted out with SGMP 3^b; if so desired, the results can be both printed and plotted. With print-outs one obtains the groundwater balances of each nodal area. With plot-outs, one can compare the calculated watertable elevations with the historical ones; in addition, plot-outs are most useful in indicating the long-term behaviour of the watertable.

The total package thus consists of six source programs and five data sets. Figure 4.1 shows the possible combinations.

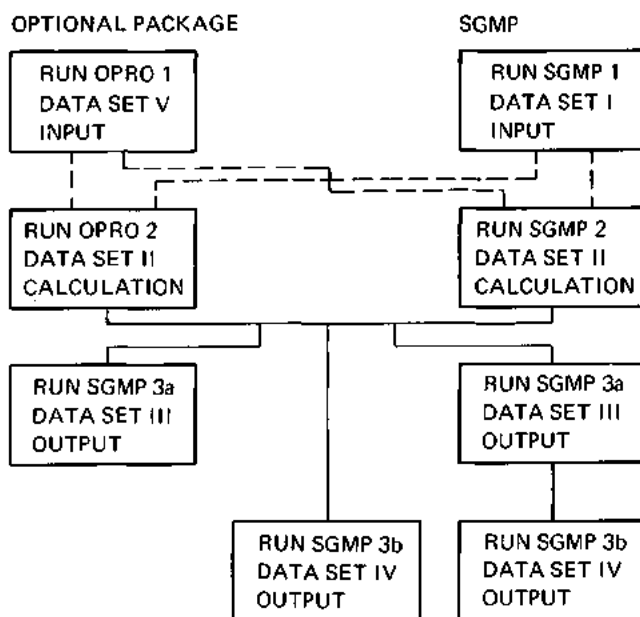

Fig. 4.1 Possible combinations of source programs and data sets

In Section 4.2 below, it will be explained how the various data sets are to be prepared. Section 4.3 will describe how the source programs can be adapted to a particular network or particular computer, if necessary. Section 4.4 is intended for the systems manager; it informs him of the specific demands placed on his computer system by the program package.

4.2 Structure of data sets

4.2.1 Data Set I

The data required for SGMP 1 are the data of the nodal network, and those of the hydrogeological parameters and other variables. For the design of a nodal network, see Chap. 3 Sect. 4; for techniques to produce the data on hydrogeological parameters, see Chap. 2 Sect. 2, and Chap. 3 Sects. 5.2, 5.3, and 5.4. The data are processed and stored in the memory (FILE 1). The output of SGMP 1 consists of a reformatted playback of the input data. This enables the user to check whether any mistakes were made when the cards were being punched.

Definitions of input variables

The input variables have been divided into eight groups, which, for the sake of convenience, are presented in the form of a table (Table 4.1). Explanations of the various items follow the table.

Table 4.1 Input variables of SGMP 1

Group 1	TITLE
Group 2	NN NSCONF NCONF NEXTN NSIDE(K), K=1,NN CO(I,J), J=1,2, I=1,TNN
Group 3	TMBAS DMTIM T SCALE LSWI

Group 4	DELTA MINOR MAJOR LIST
Group 5	ERROR COEFFA
Group 6	PERM (J), J=1,7 CO(K,1), K=1,NN PCONF(I), I=1,NSCONF ASC(I), I=1,NSCONF
Group 7	SL(K), K=1,NN BL(K), K=1,TNN CO(I,2), I=1,NCONF
Group 8	UL(K), K=1,NN OL(K), K=1,NN LSW2 DELQ

Group 1. Identification

TITLE = name of basin, or any specification the user wishes for identification.

Group 2. Parameters for the network configuration

NN = number of internal nodes. As has been explained, the area is split up into nodal areas, the nodes of which represent the specific aquifer characteristics in each area. NN is further subdivided in accordance with the types of aquifer:

NSCONF = number of internal nodes that represent a semi-confined aquifer. These nodes (if any) are numbered consecutively, starting with 1.

NCONF = number of internal nodes that represent a confined aquifer. These nodes (if any) are also numbered consecutively starting with NSCONF + 1.

The remaining internal nodes are assumed to represent an unconfined aquifer. No specific variable is attached to these nodes. They too are numbered consecutively, starting from NCONF + 1 and concluding with NN.

- NEXTN = number of external nodes. These nodes represent the boundary conditions of the area; each nodal area lying at the fringe of the area must have one or more external nodes. They are numbered from NN + 1 to TNN which is an intermediate value signifying the total number of nodes (NN + NEXTN).
- NSIDE(K) = number of sides of each internal nodal area. In the program the maximum number of sides that each nodal area can possess is restricted to seven.
- CO(I,J) = x and y coordinates of all the nodes, both internal and external. They are measured in *cm* with regard to an arbitrarily chosen cartesian coordinate system laid on the map of the network configuration. When a triangle formed by three nodes possesses an angle greater than 90 degrees, a message is printed indicating which of the nodes this is.

Group 3. Parameters concerning dimensions

- TMBAS = unit time of time step and boundary conditions. It is expressed as a word: week, month, etc.
- DMTIM = number of *days* in the unit time TMBAS.
- T = actual time at the beginning of the calculation process, expressed as a numeric in the dimension TMBAS. If the computations start on 15 August and TMBAS has the dimension MONTH, T is equal to 7.5.
- SCALE = scale of the map used for the nodal network and from which the coordinates of the nodes are read.
- LSW1 = an external switch that can be given two values. If the scale of the map is very large, the nodal areas become very large when expressed in square metres; the same applies to pumping rates expressed in cubic metres. These large values can be avoided by using LSW1. Setting LSW1 equal to 1 means:

unit area = 1,000,000 square metres
unit volume = 1,000,000 cubic metres
Setting LSW1 equal to 2 means:
unit area = 1 square metre
unit volume = 1 cubic metre.

Note: The unit length is always fixed (metre); it is used in the hydraulic conductivity values (metre/day) and in the elevation values (metres above a certain reference datum).

Group 4. Parameters of time discretization

In modelling a groundwater basin, two time parameters are indispensable. The first is the time step, which is implicit to the finite difference method; its magnitude must be determined by making a number of trial runs. The second is the total time period for which the calculations are to be made.

Two other parameters are also used in the program package. They can be regarded as accumulation levels of the time step. The reasons why these parameters are included are two-fold:

- They allow the boundary conditions to be prescribed at time intervals that are different from the time step; for example, each week or each month, depending on the available data;
- The same applies for the results of the calculations; for example, it is possible to print the watertable elevations for each month and the water balance components for each year, even though the actual time step is a week.

DELTA = time. The choice of the time-step size is initially arbitrary, although it is influenced by two factors:

- If the time step is chosen too large, the approximation of finite differences to differentials will cease to be valid and the results will be in error;
- An interaction exists between the amount of data for the boundary conditions and the size of the time step chosen;

if, for example, the boundary conditions are known on a weekly basis, one will not take a time step of one month and vice versa. For any particular set of data, it is advisable to run the program with various DELTA values. When the results are compared, it can readily be seen for what maximum value of DELTA the results do not appreciably change.

Common time steps are a week, a fortnight, or a month for regional studies and a day for local studies like aquifer tests. The dimension of DELTA is the unit time TMBAS.

- MINOR = the number of DELTA periods in the first accumulation level.
 MAJOR = the number of first accumulation level periods in the second accumulation level.
 LIST = the number of second accumulation level periods in the total time period considered.

To summarize the use of the parameters of time discretization, the values of the time step DELTA and the total time period must first be determined, after which the values of the other two parameters can be chosen. For example, computations made for a total period of five years may have the following parameters:

- unit time: one month
- time step: one fortnight
- first accumulation level: one month
- second accumulation level: one year

The relationships between the different time units as they are used in this context are: 1 year = 12 months = 24 fortnights = 48 weeks = 366 days. The values of the various parameters and their interpretation are:

Parameter	Value	Interpretation
TMBAS	MONTH	month
DMTIM	30.5	number of days in a month
DELTA	0.5	fortnight
MINOR	2	number of fortnights in a month
MAJOR	12	number of months in a year
LIST	5	number of years in total time period

To check whether the parameter values have been determined correctly, the algebraic product of the values of DELTA, MINOR, MAJOR, and LIST should be calculated; the result should equal the total time period being considered, expressed in the unit TMBAS.

Group 5. Parameters for the calculation process

ERROR = a tolerance level that directly affects the accuracy of the final results.

In the calculation process the various components of the water balance of the nodal areas are calculated. For each nodal area the algebraic sum of these components is found and set equal to RES (= residual). The watertable elevation at each node is then adjusted by the magnitude of the residual, attenuated by a relaxation coefficient. Finally, the sum of the absolute values of all the residuals is calculated. If this sum is less than or equal to the value of ERROR, the calculation of the nodal watertable elevations is completed for that time step. If not, the calculation is repeated as many times as are required to reduce the sum to a value less than or equal to the value of ERROR. Obviously, the smaller one chooses the value of ERROR, the more accurate the calculated nodal watertable elevations will be. Small values of ERROR, however, mean more iterations per time step and thus more computer time. Running the program for various values of ERROR and comparing the computer costs against the accuracy will indicate a suitable value of ERROR. If a small value of ERROR does not appreciably increase the accuracy of the calculated watertables, a higher value of ERROR should be chosen to reduce computer costs.

A check has been included in the program: if, after 50 iterations, the sum of the absolute values of all the residuals is still greater than the value of ERROR, the iterations are terminated: a message "RELAXATION FAILS TO CONVERGE" is printed, and the calculations are started for the next time step.

The dimension of ERROR is the same as for the other components of the water balance: a volume per time. The unit of volume depends on the value of the switch LSWI (1 m^3 or $1,000,000 \text{ m}^3$) and the unit time is equal to TMBAS.

An estimate of the value of ERROR could be a certain percentage - say 10 per cent - of the average absolute values of RECH(K) or FLWCON(K). In the program these two variables represent the net recharge values for each nodal area (see Chap. 3 Sect. 5.6). These averages are calculated as follows: the values of FLWCON(K) in the various nodal areas are totalled over the total time period and an average is calculated by dividing the total value of FLWCON(K) by the number of nodal areas, taking into account only those nodal areas where the values of FLWCON(K) are not equal to zero. For the values of RECH(K) the same procedure is followed, but the average is multiplied by the arithmetic mean surface area of the nodal areas.

Which average, either that based on RECH(K) or on FLWCON(K), should be taken depends on the situation. Suppose that the smallest of the two is chosen; it must then be converted to the dimensions of ERROR, i.e. both the unit volume and the unit time in which the average is expressed should be converted into the unit volume and the unit time used for ERROR. The result is then multiplied by 0.1 (10%) to obtain a first estimate of the value of ERROR.

COEFFA = relaxation coefficient. Tyson and Weber (1963) have suggested that such a coefficient can increase the speed of convergence. An optimum value for it can be obtained in the same way as for DELTA. The range of the coefficient is between 0.8 and 1.2.

Group 6. Geohydrological parameters

PERM(J) = mean horizontal hydraulic conductivity of the aquifer at each nodal side, weighted over the length of the side. The dimension is *fixed*: m/day. In the program the hydraulic conductivity for each nodal side is represented by the pair of node numbers in between which the side lies. If both nodes are internal nodes, the value of the hydraulic conductivity of the side must be prescribed twice: once for one node and once for the other (see Chap. 5 Sect. 4.1, Table 5.10). When these two values are not the same, a message is printed indicating for which pair of nodes this is so.

CO(K,1) = mean storage coefficient or specific yield of the aquifer in each nodal area, weighted over the nodal area (dimensionless). The array CO(K,1) has been used earlier for the x-coordinates; to save memory requirements, it is now used again for the storage coefficient or specific yield of the aquifer.

These two geohydrological parameters are needed for all types of aquifer. If the aquifer is semi-confined, two additional geohydrological parameters are needed:

PCONF(I) = mean vertical hydraulic conductivity of the confining layer in those nodal areas denoted as semi-confined, weighted over the nodal area (m/day).

ASC(I) = mean specific yield of the confining layer in those nodal areas denoted as semi-confined, weighted over the nodal area (dimensionless).

Group 7. Topographical parameters

Topographical parameters define the horizontal boundaries of the aquifer system. Included in the program package are three types of aquifer (Fig. 4.2).

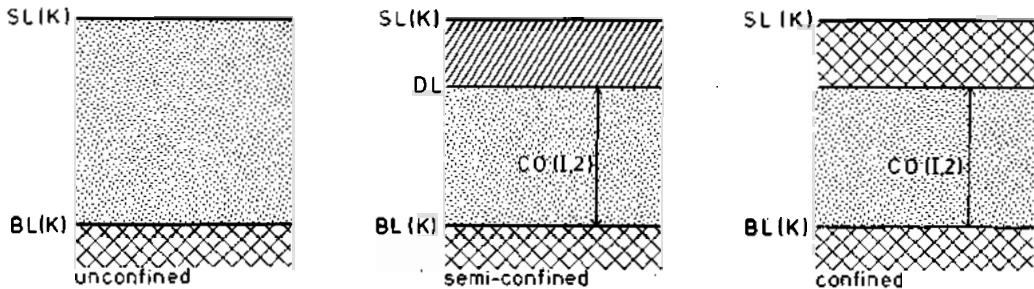

Fig. 4.2 Different types of aquifer

- SL(K) = elevation of the land surface in each nodal area, weighted over the nodal area (m above a reference level).
- BL(K) = bottom boundary of the aquifer system, in each nodal area, weighted over the nodal area *and* at each external node that represents a head-controlled boundary (m above a reference level).
- CO(K,2) = thickness of the aquifer if the nodes are denoted as semi-confined or confined, weighted over the nodal area. The array CO(K,2) has been used earlier for the y-coordinates; to save memory requirements, it is now used again for the thickness of a semi-confined or confined aquifer.

Group 8. Parameters for variations in watertable elevation

If changes are to be introduced in the groundwater basin, for example if the aquifer is to be pumped for irrigation purposes or recharged artificially, one will want to forecast the watertable behaviour under the new regime. Watertable elevations may be required to remain within certain limits, for instance if there is a risk of soil salinization due to shallow watertables, or a risk of the watertable dropping below the well screens in areas of heavy pumping.

- UL(K) = upper limit to which the watertable in each nodal area is allowed to rise. The dimension is in m above a reference level.
- OL(K) = lower limit to which the watertable in each nodal area is allowed to fall. The dimension is in m above a reference level.
- LSW2 = an external switch that can be given two values.
 Setting LSW2 equal to 2 means that no specific input values for UL(K) and OL(K) are needed. The program automatically attaches the values of SL(K) and BL(K) to respectively UL(K) and OL(K).
 Setting LSW2 equal to 1 means that the watertable elevations are prescribed within certain limits and that specific input values for these limits must be given for some or all of the nodal areas. For other nodal areas without prescribed limits, one must give UL(K) and OL(K) the values of respectively SL(K) and BL(K).

For each time step, tests are made to see whether the generated watertable elevations exceed the UL(K) and OL(K) levels. If these levels are exceeded in one or more nodal areas, the program introduces a new component into the water balance of those nodal areas and assigns a value to it that ensures that the newly generated watertable elevations remain within the given limits. This new component can be seen as an additional percolation or abstraction, depending on whether the watertable exceeds the lower or upper limit of the aquifer.

For nodal areas denoted as semi-confined or confined, the program overrules any tests on upper limits for watertable elevations, prescribing only tests on lower limits.

DELQ = coefficient that determines the speed of reaching the final value of the additional percolation or abstraction rate that will keep the watertable elevations between the prescribed limits.

The procedure by which one determines a proper value of the required additional percolation or abstraction rate is as follows.

If, after a certain time step, the watertable elevation exceeds the prescribed limit, the maximum value of the absolute values of RECH(K) and FLWCON(K) during that time step is determined. This value is then multiplied by DELQ. The product enters the water balance as the new component with a plus or minus sign, depending on which limit is exceeded. The calculation is then restarted for the same time step and the new watertable elevations are tested. If the watertable still exceeds the limit, the additional percolation or abstraction rate is increased by its own value. This procedure is repeated as many times as are needed to prevent the watertable from exceeding the particular limit.

Thus, the final value of the additional percolation or abstraction rate is a multiple of the coefficient DELQ multiplied by the maximum value of the absolute value of RECH(K) and FLWCON(K) which were input data for that time step.

Determining the value of DELQ is a matter of trial and error. When too high a value is used, the watertable will remain far from the prescribed limit. If it is too low, too many iterations will be needed before the watertable remains within the limit.

The maximum number of iterations in the program is restricted to 50. When more iterations are required, a message "DELQ IS TOO SMALL" is printed.

When the generated watertable elevation in a nodal area exceeds a limit although both the values of RECH(K) and FLWCON(K) are equal to zero during that time step, the same message "DELQ IS TOO SMALL" will be printed. Here, however, it makes no sense to enlarge DELQ, but instead, one must introduce a dummy value for either RECH(K) or FLWCON(K).

A value of 0.1 for DELQ has been found to work satisfactorily.

Sequence of cards and data formats

Table 4.2 shows the input sequence and data formats for direct key punching of the data cards of Data Set I. If the reader is not familiar with data formats he can find a brief explanation in Appendix 2.

Table 4.2 Card structure of Data Set I

Card No.	Name	Format
1	TITLE	20A4/20A4
2	NN, NSCONF, NCONF, NEXTN	4I4
3	NSIDE(K), K=1,NN	40I2
4	(CO(I,J), J=1,2), I=1,TNN	16F5.2
5	TMBAS, DMTIM, T, SCALE, LSW1	2A4,2F4.1,F8.0, I4
6	DELTA, MINOR, MAJOR, LIST	F4.2,3I4
7	ERROR, COEFFA	2F8.2
8	BL(K), K=1,TNN	20F4.0
9	K, (NS(J), PERM(J), J=1,J2)	I3,7x,7(I3, F5.2, 2x)
10	CO(I,1), I=1,NN	11F7.5
11	PCONF(K), K=1,NSCONF	10F8.4
12	ASC(I), I=1,NSCONF	11F7.5
13	SL(K), K=1,NN	20F4.0
14	CO(I,2), I=1,NCONF	20F4.0
15	LSW2, DELQ	I4,F4.1
16	UL(K), K=1,NN	10F8.4
17	OL(K), K=1,NN	10F8.4

Note that:

- If NSCONF is equal to zero, Cards 11 and 12 are skipped;
- If both NSCONF and NCONF are equal to zero, Card 14 is skipped;
- If LSW2 is equal to 2, Cards 16 and 17 are skipped.

4.2.2 Data Set II

In SGMP 2 the watertable elevations at the nodes and the water balances of the nodal areas are calculated for each time step and the results are stored on a file (FILE 2).

Apart from the data read from FILE 1 (Section 4.2.1; SGMP 1), initial and boundary conditions and four external switches are prescribed for this program. (For information on the techniques that can be applied to represent initial and boundary conditions, see Chap. 2 Sect. 3, and Chap. 3 Sects. 5.5 and 5.6).

As the results are stored on tape, the only output is the heading and the values of the four external switches. Included in the calculation process is a check against certain situations. If they occur, one of the following messages will be printed.

- "RELAXATION FAILS TO CONVERGE"
(Section 4.2.1; definition of ERROR)
- "DELQ IS TOO SMALL" (Section 4.2.1; definition of DELQ)
- "WATERTABLE IN CONFINING LAYER IS ABOVE SURFACE LEVEL"
This can happen when the positive net recharge exceeds the downward seepage or when there is an upward seepage. Physically this means that the area is waterlogged.
- "PIEZOMETER LEVEL IN AQUIFER IS BELOW BOTTOM TOP LAYER"
This can happen when by abstraction from pumped wells the piezometric level drops below the bottom of the top layer. It means that the aquifer is no longer either confined or semi-confined. When this happens, the calculations must be restarted at that time step with other values for the hydrogeological parameters.

Definitions of input variables

Group 1. External switches

- LSW3 = an external switch that can be given three values.
Setting LSW3 equal to 3 means that for every time step DELTA the boundary conditions must be specified.
Setting LSW3 equal to 2 means that for every first accumulation level (MINOR time steps DELTA) the boundary conditions must be specified.
Setting LSW3 equal to 1 means that for every second accumulation level (MAJOR \times MINOR time steps DELTA) the boundary conditions must be specified.
The actual value of LSW3 depends on the chosen time step DELTA and on the time basis for which the boundary conditions are available.
- LSW4 = an external switch that can be given two values.
Setting LSW4 equal to 2 means that the boundary conditions are read for each DELTA, first or second accumulation level depending on the value of LSW3. LSW4 is equal to 2 in the calibration process.
In operational runs the boundary conditions are usually prepared on a monthly basis for one year. For each year in the total time period, the same input data as given for the first year are used. LSW4 is then set equal to 1 and LSW3 to 2. LIST then has the dimension year and MAJOR the dimension month.
- LSW5 = an external switch that can be given two values.
Setting LSW5 equal to 1 means that a fixed time step DELTA is used in the calculation process. Its value is read in the first program SGMP 1.
Setting LSW5 equal to 2 means that a variable time step is used. For *each* time step the value of DELTA must now be prescribed, starting with the first time step, at the same time overruling the value of DELTA given in the first program SGMP 1.
A variable time step is often used in simulating aquifer tests (logarithmic time step), but for regional groundwater flow problems a fixed time step is preferred.

LSW6 = an external switch that can be given two values.
Setting LSW6 equal to 1 means that in a semi-confined aquifer the watertable elevation in the top layer is variable and is calculated from the water balance of that layer.
Setting LSW6 equal to 2 means that the watertable elevation in the top layer is fixed and is equal to the value of HCONF(K). This is valid when the program package is used to simulate aquifer tests as it is then assumed that the watertable elevation in the top layer remains constant during the test. For regional groundwater flow problems, LSW6 must be given the value 1.

Group 2. Initial conditions at time T

H(K) = initial watertable elevations of the aquifer for all internal and external nodes, measured at the nodes themselves (m above a reference level).

HCONF(K) = initial watertable elevations of the top layer for those internal nodes which are denoted as semi-confined (m above reference level).

Group 3. Boundary conditions at time >T

As explained in Chap. 3 Sect. 5.6, we have divided the net recharge data into two categories, viz. external flows with the dimension of depth per time, and external flows with the dimension of volume per time. For each category we have introduced one variable in the program. The values of these variables represent the algebraic sum of several external flows (rainfall, evapotranspiration, capillary rise, irrigation percolation losses). If the user prefers to separate these flow components, a new variable for each of them must be introduced in the program. Appendix 3 presents guidelines on how this should be done.

RECH(K) = net recharge in each internal nodal area, being the sum of a number of external flows with dimension depth per time. The unit length is fixed at one metre and the unit time is TMBAS. The

program multiplies the value of RECH(K) with the area of the particular nodal area. A positive sign means recharge to the aquifer, or if the aquifer is semi-confined, recharge to the confining layer.

FLWCON(K) = net recharge rate in each internal nodal area, being the sum of a number of external flows with dimension volume per time. The unit of volume depends on the value of the switch LSW1 (1 m³ or 1,000,000 m³); the unit of time is TMBAS. A positive sign means recharge to the aquifer.

H(K) = watertable elevations in the external nodes that simulate head-controlled boundaries. For the other external nodes (flow-controlled) no specific value of H(K) is required. The dimension is m above a reference level.

DELTA = time step, if LSW5 equals 2; see definition in Section 4.2.1.

Note: For unconfined aquifers both RECH(K) and FLWCON(K) can be used; for confined aquifers only FLWCON(K) can be used, for semi-confined aquifers RECH(K) can be used for the confining layer and FLWCON(K) for the aquifer itself.

Sequence of cards and data formats

Table 4.3 shows the input sequence and data formats for direct key punching of the data cards of Data Set II.

Table 4.3 Card structure of data Set II

Card No.	Name	Format
1	LSW3, LSW4, LSW5, LSW6	4I4
2	H(K), K=1,TNN	10F8.2
3	HCONF(K), K=1,NSCONF	10F8.2
4	RECH(K), K=1,NN	8x, 14F5.3
5	FLWCON(K), K=1,NN	8x, 7F10.4
6	H(K), K=NO,TNN	8x, 9F8.2
7	DELTA	F6.4

Note the following:

- If NSCONF is equal to zero, Card 3 is skipped.
- The set of Cards 4, 5, and 6 are repeated:

LIST times if LSW3=1

LIST × MAJOR times if LSW3=2

LIST × MAJOR × MINOR times if LSW3=3

This is the case for LSW4=2; for the combination of LSW4=1 and LSW3=2, the set of Cards 4, 5, and 6 are repeated MAJOR times.

- If LSW5 is equal to 1, Card 7 is skipped.

4.2.3 Data Set III

SGMP 3^a prints the results of the calculation in tabular form. Prescribed for SGMP 3^a - along with the calculated watertable elevations and water balance components, which are read from a file (FILE 2) - are values for the three external switches. These provide the user with options for the output.

Definitions of input variables

LSW7 = an external switch that can be given three values.
Setting LSW7 equal to 1 means that the watertable elevations are printed at each time step DELTA.

Setting LSW7 equal to 2 means that the watertable elevations are printed at each first accumulation level (MINOR time steps DELTA).

Setting LSW7 equal to 3 means that the watertable elevations are printed at each second accumulation level (MAJOR × MINOR time steps DELTA).

LSW8 = an external switch that can be given three values.
The meanings of the values 1, 2, and 3 for this switch are analogue to those for LSW7. Instead of printing watertable elevations at various time levels, the components of the water

balance of the nodal areas are calculated *over* the various time levels and printed after each particular time level.

LSW9 = an external switch that can be given two values. Setting LSW9 equal to 1 means that only the water levels of the internal nodes are printed. Setting LSW9 equal to 2 means that the water levels of both internal and external nodes are printed. This is usually done only once to check the head-controlled boundaries numerically.

With the aid of these switches, the user can choose the interval for which he wants the results printed. For example, the watertable elevations can be printed each month and the water balance each year.

Sequence of cards and data formats

As the required data are read from a file (FILE 2), the three external switches are the only input data for SGMP 3^a (Table 4.4).

Table 4.4 Card structure of Data Set III

Card No.	Name	Format
1	LSW7, LSW8, LSW9	3I4

Definitions of output variables

H SEMICONF = watertable elevation of the aquifer if it is semi-confined.
H CONFINED = watertable elevation of the aquifer if it is confined.
H UNCONF = watertable elevation of the aquifer if it is unconfined.
H' = watertable elevation of the confining layer if the aquifer is semi-confined.

T = actual time expressed as a numeric in the dimension TMBAS.

NO. OF ITERATIONS = number of iterations required in the Gauss-Seidel technique (SGMP2) to reduce the sum of all residual values to a value that is equal to or less than the prescribed threshold value ERROR. When using the elimination technique (OPRO2), the print-out will show "NO. OF ITERATIONS = 0".

NO. OF SUBITERATIONS = number of iterations required to bring one or more of the calculated watertable elevations within the prescribed limits UL(K) or OL(K) (see Chap. 3 Sect. 2.1). To distinguish this process from the convergence process, these iterations are denoted as subiterations. When the number of subiterations is not equal to zero, the print-out will show, under the heading DRAINAGE FLOW, the amount(s) of artificial percolation and/or abstraction necessary to keep one or more of the calculated watertable elevations within the prescribed limits.

RECHARGE = a reformatted playback of the recharge input data. This is the lumped sum of the recharge components that initially had the dimension of a depth per time. In the program this lumped sum is multiplied by the area of the nodal area concerned, so the printed values have the dimension of a volume per time. A positive sign means percolation to the aquifer, or if it is not unconfined, percolation to the confining layer; a negative sign means abstraction from the aquifer or confining layer.

CHANGE IN STORAGE IN TOP LAYER = the calculated amount of water stored in or released from the confining layer. This value is the algebraic product of the change in head in the confining layer, the storage coefficient of that layer, and the area of the nodal area concerned. A positive sign means that water is released from the layer and a negative sign means that water is stored in the layer.

SEEPAGE FLOW = the calculated amount of water stored in or released from the aquifer. This value is the algebraic product of the difference in head between the aquifer and its confining layer, the vertical hydraulic conductivity of the confining layer, and the area of the nodal area concerned, divided by the saturated thickness of the confining layer. A positive sign means that the flow direction is from the confining layer to the aquifer and a negative sign that the flow direction is from the aquifer to the confining layer.

CHANGE IN STORAGE IN AQUIFER = the calculated amount of water stored in or released from the aquifer itself. This value is calculated in the same way as that for the change in storage in the confining layer.

TOTAL SUBSURFACE FLOW = the calculated amount of water stored in or released from the nodal area concerned. This value is the net sum of the subsurface flows through all the sides of the nodal area. Each subsurface flow is the algebraic product of the hydraulic gradient between the node itself and one of its neighbouring nodes, the hydraulic conductivity, the saturated thickness of the aquifer between these nodes, and the length of the nodal area's side. A positive sign means that there is a net inflow of subsurface flow into the nodal area and a negative sign means that there is a net outflow from the nodal area.

PUMP FLOW = a playback of the recharge input data. This is the lumped sum of the recharge components that already had the dimension of a volume per time. A positive sign means percolation to the aquifer and a negative sign means abstraction from the aquifer.

DRAINAGE FLOW = the calculated quantity of water, additionally stored in or released from the aquifer, to keep the water-table between the prescribed limits. A positive sign means additional percolation to the aquifer and a negative sign, additional abstraction from the aquifer.

For each time step, the actual time and the number of iterations and subiterations, if any, are printed. Depending on the actual values of LSW7 and LSW8, watertable elevations at the nodes and water balance components of the nodal areas are printed over various time levels. These water balance components should be read as follows:

- For unconfined and confined aquifers there is one water balance: recharge + change in storage in aquifer + total subsurface flow + pump flow + drainage flow = residual value.
- For semi-confined aquifers there are two water balances, one for the aquifer itself and one for the confining layer:
 - (i) seepage flow + change in storage in aquifer + total subsurface flow + pump flow + drainage flow = residual value
 - (ii) recharge + change in storage in confining layer - seepage flow = another residual value.

With the aid of the actual values of the water balance components, the user can check whether the residual value for the aquifer is acceptable; if not, he must choose a smaller value of ERROR (see Data Set I).

Note: A slight discrepancy exists between the printed watertable elevations and two of the printed water balance components related to the watertable elevations (i.e. change in storage and subsurface flow). The values of those water balance components correspond to watertable elevations as they were calculated during the second last iteration, whereas only in the last iteration are the watertable elevations adjusted.

4.2.4 Data Set IV

SGMP 3^b presents the watertable elevations at the nodes in graphical form. We have chosen to have this done by a line printer instead of a plotter for two reasons. The first is that a plotter works more slowly and is thus more expensive to use, and the second is that not every computer centre has plotter facilities. A disadvantage is that the graphs consist of isolated points instead of continuous lines.

Prescribed for SGMP 3^b - along with the calculated watertable elevations, which are read from a file (FILE 2) - are various signs for the plot and values for three external switches. For the calibration process, the historical watertable elevations are prescribed. (For information on historical watertable elevations, see Chap. 2 Sect. 3.1). For operational runs the values of MINOR, MAJOR, and LIST must be reread.

Definitions of input variables

- BLNK = always a blank.
- HI = a sign that indicates the unit of scale.
- HMINUS = a sign that indicates the tenth of the unit of scale.
- HX = a sign that indicates when a computed watertable elevation falls outside the maximum range of the scale.
- ASTRSK = a sign that indicates the position of a calculated watertable elevation in the graph.
- HY = a sign that indicates when a historical watertable elevation falls outside the maximum range of the scale.
- PLUS = a sign that indicates the position of a historical watertable elevation in the graph.
- LSW9 = an external switch that can be given two values.
Setting LSW9 equal to 1 means that only the watertable elevations at the internal nodes are plotted.
Setting LSW9 equal to 2 means that the watertable elevations at the internal and external nodes are plotted. Usually this is done only once to provide a visual check of the head-controlled boundaries.
- LSW10 = an external switch that can be given two values.
Setting LSW10 equal to 1 means that both calculated and historical watertable elevations are plotted. This is required for the calibration process, in which the calculated watertable elevations are compared with the historical ones.
Setting LSW10 equal to 2 means that only the calculated watertable elevations are plotted. This is done in operational runs, when no historical water levels are required as input.

LSW11 = an external switch that can be given two values.
Setting LSW11 equal to 1 means that an error calculation is made of the deviations between the calculated and historical watertable elevations. For all the internal nodes of the network, these deviations are calculated for each time step for which historical watertable elevations are available; the mean and standard deviation are then calculated and printed at the end of all the plots.

Note: We have found that after having made some calibration runs (Chap. 6 Sect. 1.1) we could not always see whether the results of the last calibration run were an improvement on the preceding ones, especially when the network consists of a great number of internal nodes. We then found that an error calculation could be helpful. The mean gives a general indication of whether the model is predominantly underestimating or predominantly overestimating the measured watertable elevations, whereas the standard deviation gives a direct measure of the degree of improvement of any run over any previous run. In general, one can say that the smaller the standard deviation, the better the generated watertable behaviour, even if the mean is slightly higher than in a previous run. It is stressed that the actual values of mean and standard deviation are only an expedient; first of all, one must visually inspect the calculated watertable elevations and examine the calculated water balance components.

Setting LSW11 equal to 2 means that no error calculation is made. In production runs LSW11 must be made equal to 2, because there are then no historical watertable elevations to be compared.

MINOR : In operational runs these parameters should be given values
MAJOR that differ from those prescribed in the calculation program.
LIST Suppose the model is run for 30 years with a time step of a fortnight and the boundary conditions are prescribed on a monthly basis. The parameters of the time discretization are then:

TMBAS : month

DELTA : 0.5

MINOR : 2

MAJOR : 12

LIST : 30

Using the same values in the plot program would mean that the water levels are plotted for each month, because they are plotted at the end of each first accumulation level. In general, one will not need that much information, and water levels plotted after each half year will usually suffice. The values of MINOR, MAJOR, and LIST are then:

MINOR : 12

MAJOR : 60

LIST : 1

H(K,M) = historical watertable elevations of the aquifer for all internal nodes.

The maximum range of the plot is ten units of scale; the scale is not fixed, but depends on the range of the historical and calculated watertable elevations; the minimum scale is 1 metre and the maximum 8 metres. The number of watertable elevations printed in one plot depends on the value of MAJOR. When, for instance, for a calibration, historical watertable elevations are available on a monthly basis for a period of two years, the value of MAJOR is 24. In our plot program the maximum number of watertable elevations in one plot is 36. If one wishes to increase this number, one must adjust the value of MAJOR in the array dimensions of SGMP 3^b (see Appendix 1).

If one is using a mini-computer and is facing problems of memory requirements, a solution is to split up the plots by making MAJOR in Data Set I equal to 12. Suppose that one is simulating a period of ten years for which historical data are available on a monthly basis. If the values of LIST and MAJOR in Data Set I have been chosen as 1 and 120 respectively, the value of MAJOR in the array dimensions of SGMP 3^b must then be adjusted to 120 and the output of SGMP 3^b will show for each node all the 120 historical and calculated watertable elevations in one plot. For mini-computers such an increase in the value of MAJOR could result in an error message that the computer memory is not big enough to store all the data. One can avoid this problem by making LIST and MAJOR in Data Set I equal to 10 and 12 respect-

ively and reducing the value of MAJOR in the array dimensions to 12. This will substantially reduce the memory requirement. As a result, the output of SGMP 3^b will show for each node 10 plots of 12 historical and calculated watertable elevations. A disadvantage is that the interpretation of the results is more difficult because the data are spread over various plots.

Sequence of cards and data formats

Table 4.5 shows the input sequence and data formats for direct key punching of the data cards of Data Set IV; the other required data are read from a file (FILE 2).

Table 4.5 Card structure of Data Set IV

Card No.	Name	Format
1	BLNK, HI, HMINUS, HX, ASTRSK, HY, PLUS, LSW9, LSW10, LSW11	7A4,3I2
2	MINOR, MAJOR, LIST	3I4
3	H(K,M), K=1,NN, M=1,MAJOR	8x,9F8.2

Note that:

- If LSW10 is equal to 1, Card 2 is skipped.
- If LSW10 is equal to 2, Cards 3 are skipped.

4.2.5 Data Set V

The data required for OPRO 1 are the same as for SGMP 1: data concerning the network, and those of the hydrological parameters and other variables. The data are processed and stored in the memory (FILE 1). The output is also the same as for SGMP 1.

To compose a rectangular network, a system of rectangles and/or squares is superposed on the area (Fig. 4.3). An arbitrary origin is chosen with the

x-axis in horizontal direction (positive to the right) and the y-axis in vertical direction (positive downwards).

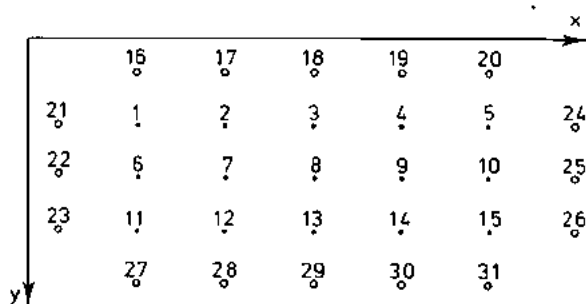

- internal node
- external node

Fig. 4.3 Lay-out of rectangular network

The internal nodes of the network are numbered in a fixed sequence, from left to right (positive x-direction) row after row. The external nodes of the network are also numbered in a fixed sequence: first the network's top boundary, then its left- and right-hand-side boundaries, and finally its bottom boundary. These nodes are numbered consecutively in the positive direction.

The following input variables are used for this network:

- NX = number of internal nodes in x-direction
- NY = number of internal nodes in y-direction
- RX(I), I=1, NX = x-coordinates of the internal nodes along a line parallel to the y-axis
- RY(I), I=1, NY = y-coordinates of the internal nodes along a line parallel to the x-axis
- COTBY = y-coordinate of the external nodes of the top boundary
- COBBY = y-coordinate of the external nodes of the bottom boundary
- CORBX = x-coordinate of the external nodes at right-hand-side boundary

COLBX * x-coordinate of the external nodes at the left-hand-side boundary

Definitions of input variables

In this program the aquifer is assumed to be homogeneous except along its boundaries, where other hydraulic conductivity values can be prescribed.

The geohydrological parameters are:

SLC = upper boundary of the aquifer system
BLC = lower boundary of the aquifer system
STO = specific yield or storage coefficient of the aquifer
CONDOC = hydraulic conductivity of the aquifer
CONDTC = hydraulic conductivity along the network's top boundary
CONDCB = hydraulic conductivity along the network's bottom boundary
CONDRB = hydraulic conductivity along the network's right-hand-side boundary
CONDLB = hydraulic conductivity along the network's left-hand-side boundary

These eight parameters are needed for all types of aquifer. If the aquifer is semi-confined, three additional geohydrological parameters are needed:

STOCON = specific yield of the confining layer
PCONC = hydraulic conductivity of the confining layer for vertical flow
THID = thickness of the aquifer

The last parameter is also needed when the aquifer is confined.

The dimensions of all the above variables are the same as in SGMP 1.

Sequence of cards and data formats

Table 4.5 shows the input sequence and data formats for direct key punching of data cards of Data Set V.

Table 4.5 Card structure of Data Set V

Card No.	Name	Format
1	TITLE	20A4/20A4
2	NX, NY, NSCONF, NCONF, NEXTN	5I4
3	SLC, BLC, STO, CONDUCT	2F4.0,F7.5,F8.4
4	COTBY, COBBY, CORBX, COLBX, CONDTB, CONDBB, CONDRB, CONDLB	8F5.2
5	TMBAS, DTIM, T, SCALE, LSW1	2A4,2F4.1,F8.0,I4
6	DELTA, MINOR, MAJOR, LIST	F4.2,3I4
7	ERROR, COEFFA	2F8.2
8	LSW2, DELQ	I4,F4.1
9	ULC, OLC	2F4.0
10	RX(I), I=1,NX	16F5.2
11	RY(I), I=1,NY	16F5.2
12	PCONC, STOCON	F8.4,F7.5
13	THID	F4.0

Note that:

- If LSW2 is equal to two, Card 9 is skipped.
- If NSCONF is equal to zero, Card 12 is skipped.
- If both NSCONF and NCONF are equal to zero, Card 13 is skipped.

4.3 Program adaptations

4.3.1 Adaptations to nodal network

Required at the beginning of all computer programs is a block of array dimensions, an array being a collection of variables of one specific type. PERM(7), for instance, is an array called PERM with 7 variables. Figure 4.4 presents part of the listing of SGMP 1 showing the array dimensions.

```

C   GROUNDWATERMODEL/PART: 1 READING INPUT DATA(POLYGONS/INHOMOGENOUS)
    INTEGER TNN
    REAL LENGTH
    DIMENSION PERM(7),NS(7),TITLE(40),TMBAS(2)
    DIMENSION ASC( NN),UL( NN),OL( NN),AREA( NN),AS( NN),SL( NN)
    DIMENSION OL(TNN),NSIDE( NN),PCONF( NN),NREL( NN,7),CONDU( NN,7)
    DIMENSION CO(TNN,2)

```

Fig. 4.4 Array dimensions (SGMP 1)

Of the array dimensions in our programs, the only ones that may need to be adapted are those related to the nodal network. The network used in the programs comprises 71 internal nodes, signifying nodal areas, and 39 external nodes, signifying boundary conditions - a total of 110 nodes. If the user's network comprises 110 nodes or less, no adjustments need to be made in the network array dimensions. If his network comprises more than 110 nodes, however, he must increase the array dimensions accordingly. If his computer has insufficient memory capacity to cope with 110 nodes, he must reduce the array dimensions accordingly.

The complete listings of our programs is given in Appendix 1. In these listings the array dimensions of the nodal network are presented as NN and TNN, with NN denoting the number of internal nodes and TNN the total number of nodes (internal + external). If the user's network comprises, say, 90 internal nodes and 44 external nodes, he must replace NN with 90 and TNN with 134 in all the programs that he uses.

4.3.2 Adaptations to computer systems

Each computer consists of a "central memory", in which the calculations are performed, and "peripheral devices", which provide for the input/output handling. The peripheral devices used in our programs are the "card-reader", the "line printer", and "two scratch files on the disk mass storage". Assigned to each device is a "logical device number", which differs from one computer to another. In our source programs, the logical device number for the card reader is 8, that for the line printer is 5, and those for the two scratch files are 1 and 2. Figure 4.5 shows part of the listing of SGMP 2 as an illustration.

```

C      DIMENSION OL(TNN),UL( NN),OL( NN),THID( NN),SL( NN)
      IRO=8
      IPR=9
      IOSK1=1
      IOSK2=2
      REWIND IOSK1
      READ(IOSK1) DELQ,COEFFA,T,NN,NO,TNN,ERROR,DELTA,NCONF,LSN1

```

Fig. 4.5 Logical device numbers

If the computer operator prescribes other values for the logical device numbers, the new values must be inserted in all the programs.

Cyber computer systems require that the first card of each source program be a "program card". A program card states the name of the program, the peripheral devices used, and their logical device numbers.

Figure 4.6 shows the program cards for the four source programs of the program package.

Our programs are suitable for computers in which a "word" contains at least 16 "bits". If the user's computer has fewer bits in a word, the accuracy of the results will be endangered. He is then advised to use "double precision", which is achieved by inserting certain cards after the first card in each source program. Figure 4.7 shows an example of such cards. Depending on the Fortran compiler features in use in the system, declaratives other than "implicit real*8" and "real*8" may have to be used.

Input data	PROGRAM LINPUT(INPUT,OUTPUT,TAPE8=INPUT,TAPE5=OUTPUT,TAPE1)
Calculation	PROGRAM CALCU(INPUT,OUTPUT,TAPE8=INPUT,TAPE5=OUTPUT,TAPE1,TAPE2)
Print-out	PROGRAM PRINT(INPUT,OUTPUT,TAPE8=INPUT,TAPE5=OUTPUT,TAPE2)
Plot-out	PROGRAM PLOT(INPUT,OUTPUT,TAPE8=INPUT,TAPE5=OUTPUT,TAPE2)

Fig. 4.6 Examples of program cards

Input data	IMPLICIT REAL*8 (A-H,O-S,U-Z) REAL*8 TMBAS,T
Calculation	IMPLICIT REAL*8 (A-H,O-R,U-Z) REAL*8 TMBAS,T,THID,TOTALQ,S,SC,SL,THI,SUM
Print-out	IMPLICIT REAL*8 (A-H,O-R,U-Z) REAL*8 TMBAS,T,SL,TOTALQ,S,SC,TOTRE,TOTFC,TOTSO,TOTS,TOTOS,TOTSC REAL*8 TOTDQ,TTRE,TTSQ,TTT,TTSC,TTFC,TTQS,TTDQ
Plot-out	IMPLICIT REAL*8 (A-H,O-S,U-Z) REAL*8 TMBAS,T,SL,TI,SCALE

Fig. 4.7 Example of cards for double precision

4.4 Some remarks for the system manager

(If the system manager is not available, the user should consult either the shift-leader or operator).

The program consists of either three or four source programs, depending on which combination is chosen by the user (see also Fig. 4.1). Each program is followed by its own data set. The programs must be run in one batch string and in a certain sequence. Figure 4.8 shows the structure of the deck of cards used for the four programs of SGMP. Please advise the user which job control language cards he should use to run the program.

While the programs are being run, there is a data transfer from or to scratch files on the disk mass storage. These files are unformatted and in binary form. File 1 is created in the first source program and is used in the second. Its records are as follows:

```
WRITE(IDSK1) DELQ,COEFFA,T,NN,NO,TNN,ERROR,DELTA,NCONF,LSN1
WRITE(IDSK1) TITLE,TMBAS,(BL(K),K=1,TNN),LIST,MAJOR,MINOR,NSCONF
WRITE(IDSK1) (UL(K),OL(K),SL(K),AREA(K),AS(K),NSIDE(K),K=1,NN)
WRITE(IDSK1) ((NREL(K,J),CONDU(K,J),J=1,7),K=1,NN)
IF(NCONF,GT,0) WRITE(IDSK1) (CD(I,2),I=1,NCONF)
IF(NSCONF,GT,0) WRITE(IDSK1) (ASC(K),PCONF(K),K=1,NSCONF)
```

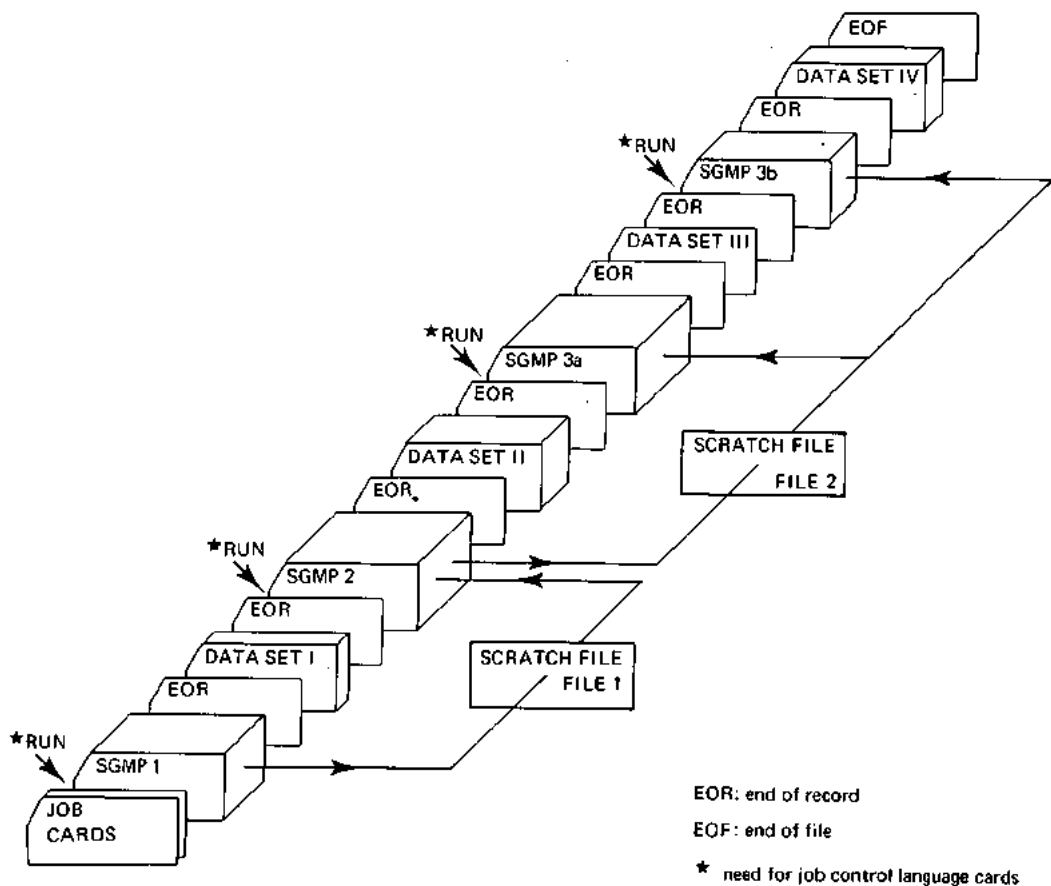

Fig. 4.8 Example of deck structure

In the second source program, another file, FILE 2, is created and is used in the third or fourth programs or both, depending on the combination of programs chosen. Its records are as follows:

```

WRITE(IDSK2) LIST,MAJOR,MINOR,DELTA,T,NN,TNN,LSW1
WRITE(IDSK2) (H(K),K=1,TNN),NSCONF,(SL(K),K=1,NN),NCONF,TITLE,TMBA9
IF(NSCONF,GT,0) WRITE(IDSK2) (MCONF(K),K=1,NSCONF)
  DO 98 L=1,LIST
31  DO 88 M=1,MAJOR
5   DO 78 JT = 1,MINOR
WRITE(IDSK2) (RECH(K),TOTALQ(K),S(K),FLWCON(K),DRECH(K),K=1,NN)
WRITE(IDSK2) (H(K),K=1,TNN),T,ITRNO,DELTA,SUBITR
IF(NSCONF,GT,0) WRITE(IDSK2) (MCONF(K),QSEEP(K),SC(K),K=1,NSCONF)
78  CONTINUE
88  CONTINUE
98  CONTINUE

```

Depending upon the values of the array dimensions, there can be a problem of finding enough space on the disk mass storage. An alternative would then be to transfer these two data files to magnetic tape.

If the programs are to be run often, make reloadable modules of the source programs and adjust the job control language cards accordingly.

5 SAMPLE RUN

5.1 Introduction

Before a program can be run on a computer, the data have to be transferred from maps to a nodal network, from a nodal network to tables, and finally from tables to computer cards. We shall illustrate the process with a hypothetical example. By using a hypothetical example instead of a real one, we can restrict the number of nodal areas to only a few, thus avoiding the reproduction of lengthy tables. A hypothetical example also gives us the freedom to introduce various boundary conditions and to impose arbitrary hydrological stresses on the aquifer system.

For our example we shall use the complete set of the Standard Groundwater Model Package (SGMP), which means that we must prepare four data sets.

5.2 Description of the area

Our hypothetical area represents part of a graben valley. The valley originates from a downfaulting between two WNW-ESE striking faults of which only one is shown in Figure 5.1. To the west, another fault crosses the valley from north to south. Massive granite blocks form the valley walls. On the upthrown block to the west, a relatively thin sandstone aquifer overlies the granitic bedrock. A river enters the downthrown block through a gorge. The downthrown block is entirely filled with unconsolidated river

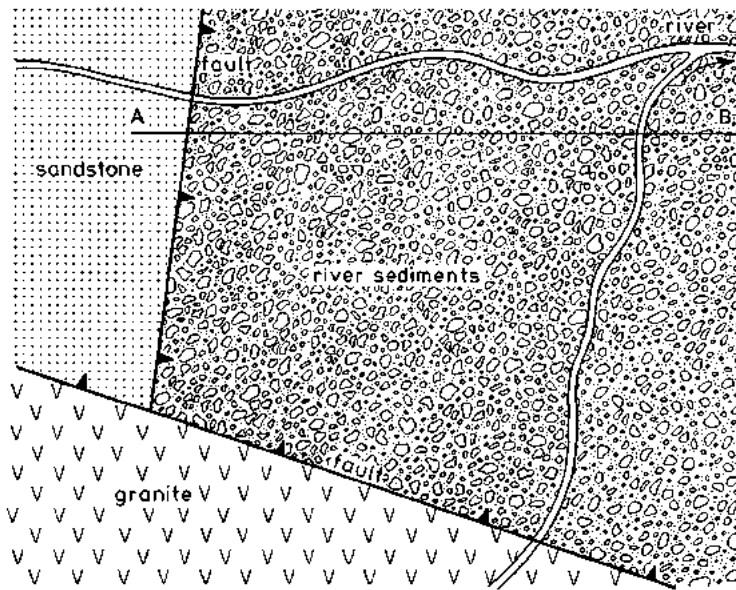

Fig. 5.1 Hypothetical area

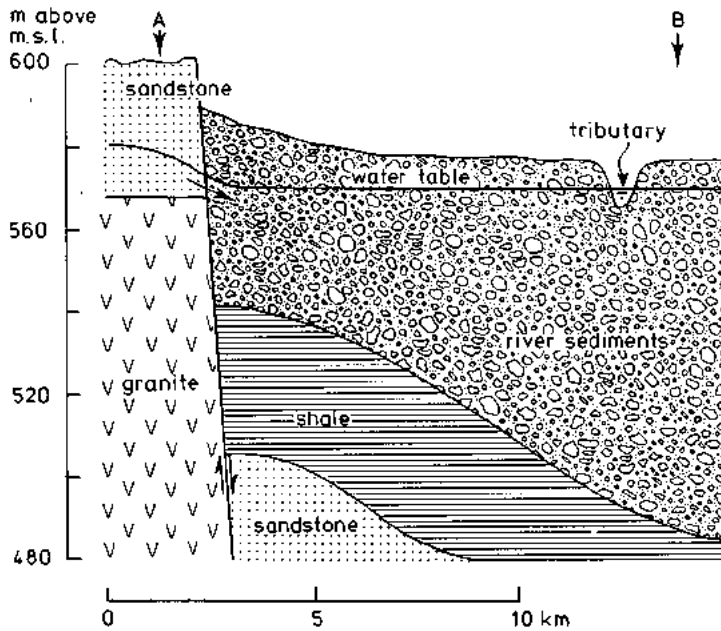

Fig. 5.2 Longitudinal section of the hypothetical area

sediments whose grain sizes vary from very coarse at the mouth of the gorge to finer textured downstream. A tributary, rising on the southern granitic block, has built an alluvial fan into the valley. The coarse material of the fan becomes progressively finer grained downstream. A study of available well logs reveals that a thick bed of shale underlies the river sediments of the downthrown block; the surface of the shale dips in downstream direction. The geology of the area is shown schematically in Figure 5.1 and a geologic section in Figure 5.2.

A groundwater model is required for the area bounded by the river and its tributary, the WNW-ESE fault, and the western N-S fault. The available logs of wells and boreholes and readings from observation wells and some double piezometers reveal that the aquifer is unconfined. The total area of the aquifer to be modelled is 78 km².

The boundary conditions are defined as follows:

- As the river and its tributary are perennial, they are considered to represent head-controlled boundaries. Although their water levels change in the course of the year, mean fixed water levels are assumed in the calculations.
- In the south, the WNW-ESE fault is considered to represent a zero flow boundary because the aquifer terminates there against the massive block of granite which does not transmit any appreciable amount of groundwater.
- In the west, the N-S fault is considered to represent a flow-controlled boundary, because the sandstone overlying the granite contains a watertable that stands higher than that in the aquifer to the east of the fault. From available data on rainfall and surface runoff, we assume an average percolation of rain in the sandstone that corresponds with an average groundwater flow across this fault of 15 l/s per km length of the fault.

Figure 5.3 shows the configuration of the nodal network used for the example. The five internal nodes (Nodes 1 to 5) were selected arbitrarily. The external nodes needed to construct the network are those in the river and its tributary (Nodes 6 to 11) and those beyond the faults: Node 12 (opposite Node 4), Nodes 13 and 14 (opposite Node 5), and Node 15 (opposite Node 1). As explained in Chapt. 3 Sect. 4 the Thiessen method was used to construct the network.

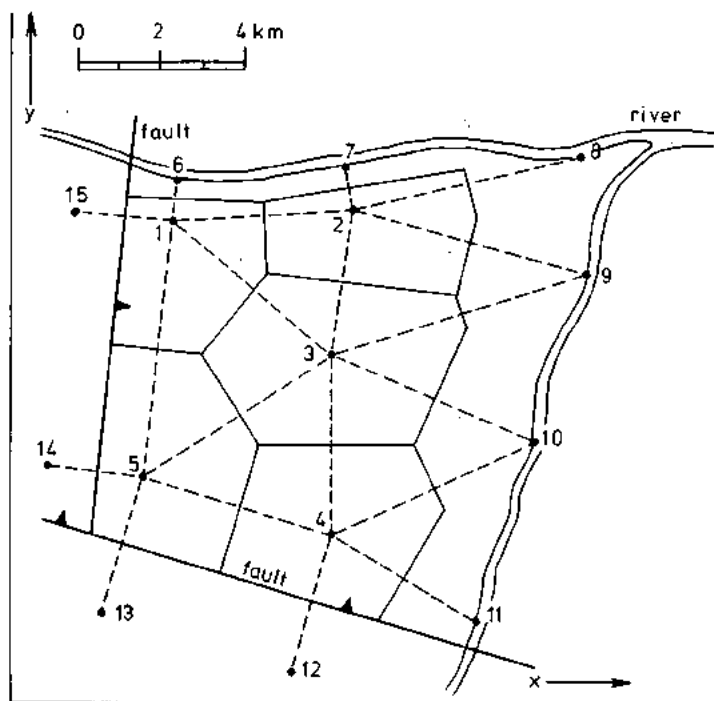

Fig. 5.3 Configuration of the nodal network and coordinate system for determining the coordinates of the nodes

5.3 Data preparation

The procedure of preparing data for our groundwater model is as follows.

5.3.1 Parameters for the configuration of the network

As shown in Figure 5.3, the area is modelled in five nodal areas, so NN is 5. The boundaries are represented by 10 external nodes, so NEXTN = 10. Figure 5.2 shows that the modelled area is part of an unconfined aquifer, so NSCONF = 0 and NCONF = 0.

The number of sides of each nodal area and the coordinate values of each node are read from Figure 5.3. These data are presented in Table 5.1.

Table 5.1 Parameters of network configuration

Number of node K	NSIDE(K)	CO(K,1) (x-coordinate)	CO(K,2) (y-coordinate)
1	5	4.45	12.55
2	5	8.80	12.80
3	6	8.35	9.25
4	5	8.35	4.90
5	5	3.75	6.30
6	-	4.50	13.55
7	-	8.60	13.90
8	-	14.20	14.15
9	-	14.40	11.30
10	-	13.15	7.20
11	-	11.75	2.80
12	-	7.35	1.55
13	-	2.75	3.00
14	-	1.35	6.55
15	-	2.05	12.80

Note: The coordinates of the external nodes must also be prescribed as these values enable the computer to calculate the area of each nodal area.

5.3.2 Parameters of dimensions

Recharge and abstraction rates and the conditions along the head-controlled boundaries are known on a monthly basis, so TMBAS = MONTH, and DMTIM = 30.5. The calculations are started on 1 December ($T=0$). The scale of the map on which the nodal network is drawn is 1:100,000, so SCALE = 100,000. Because the hypothetical area is large, the dimensions for area and volume are taken as 1,000,000 square metres and 1,000,000 cubic metres, respectively, so LSW1 = 1.

5.3.3 Parameters of time discretization

A time step of one month is chosen for the calculation procedure, so $\Delta T = 1$, TMBAS being one month. The total time period for which the calculations are to be made is taken as one year. Because the algebraic product of the values of ΔT , MINOR, MAJOR, and LIST must be equal to the total time period expressed in the unit TMBAS, the following arbitrary values have been chosen:

MINOR : 1
MAJOR : 12
LIST : 1

5.3.4 Geohydrological parameters

As we assume the presence of an unconfined aquifer throughout the valley, we must prepare mean hydraulic conductivity values for all sites where aquifer tests took place or where boreholes or wells were drilled.

Figure 5.4 shows the network superimposed on the isoperm map, which shows lines of equal weighted mean hydraulic conductivity.

For all the sides of the nodal areas, a representative hydraulic conductivity $PERM(J)$ (m/d) is determined, either by interpolation or by the calculation of a weighted mean value, depending on whether the isoperms are parallel or perpendicular to the sides, respectively.

Note: The WNW-ESE fault represents a barrier boundary. Its hydraulic conductivity is therefore zero. The N-S fault is a flow-controlled boundary but its hydraulic conductivity is set equal to zero because the groundwater inflow there is accounted for in the net pumped abstractions of Nodal Areas 1 and 5.

As the aquifer is unconfined, we now need representative values of the specific yield in the nodal areas. In Figure 5.5 the network is superimposed on the map showing lines of equal weighted mean specific yield of the aquifer. As explained earlier, this map is compiled from aquifer test

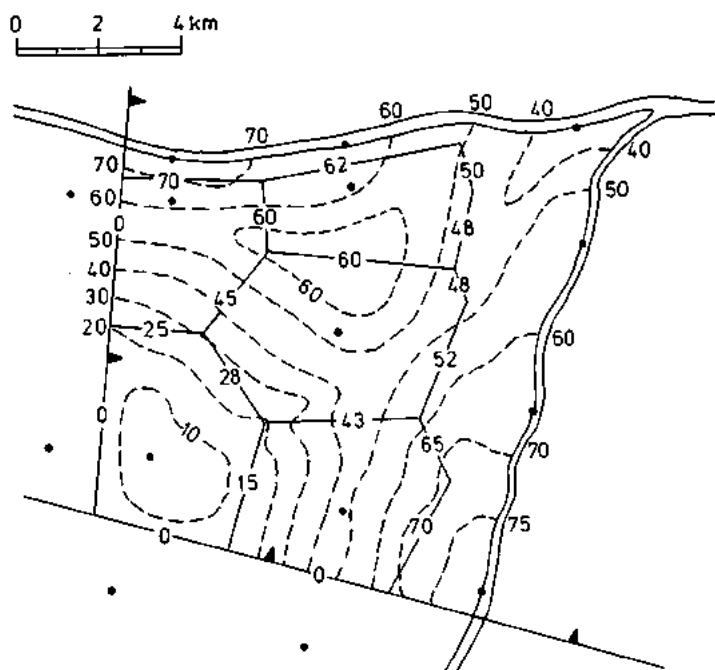

Fig. 5.4 Network superimposed on the isperm map, which shows lines of equal weighted mean hydraulic conductivity (m/d)

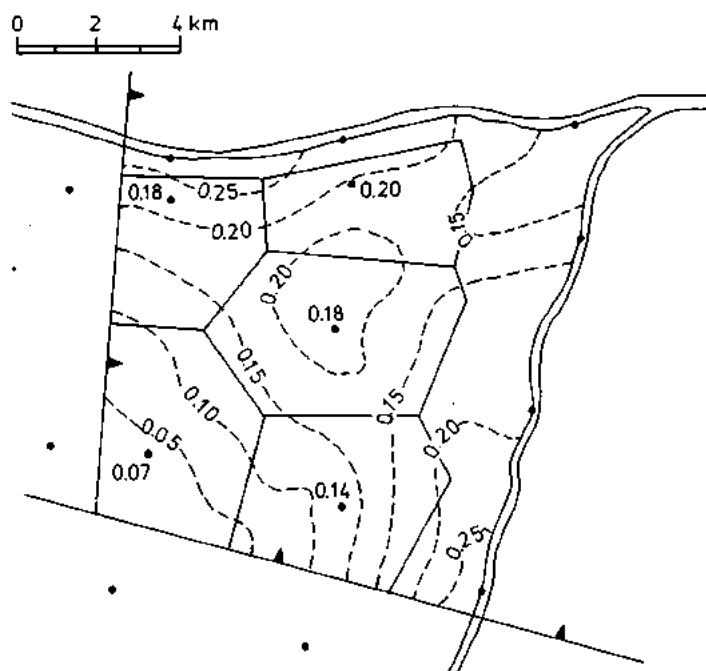

Fig. 5.5 Network superimposed on the map showing lines of equal weighted mean specific yield of the aquifer

data and by estimating weighted mean specific yield values $CO(K,1)$ from bore and well logs over a section extending from the land surface to some 10 to 20 m below the average watertable depth. Representative specific yield values for all the nodal areas are determined from the iso-specific yield lines and weighted over the area of each nodal area.

5.3.5 Topographical parameters

A study of available well logs, bore logs, and geophysical data shows that a thick bed of shale represents the impermeable base of the aquifer. Owing to tectonic events in the past, the surface of the shale is not horizontal but slopes from west to east.

Figure 5.6 shows the network superimposed on a contour map of the shale surface. The configuration, gradient, and elevation of this surface can be derived from this map and the weighted mean elevation for each of the nodal areas can be determined. The results are indicated at each node in m above mean sea level.

Note: Elevations of the impermeable base are required not only for the internal nodes but also for the nodes in the rivers, which are head-controlled. No such elevations are needed for the external nodes to the south and west of the two faults.

Figure 5.7 shows the network superimposed on the topographical map showing contour lines of the land surface in m above mean sea level. The weighted mean land surface elevations of the five nodal areas are indicated at each node.

In our example, no restrictions are imposed on the watertable fluctuations, so $LSW2 = 2$. This means that the calculation program only checks whether the watertable elevations remain within the imposed limits defined by the impermeable base and the land surface elevations.

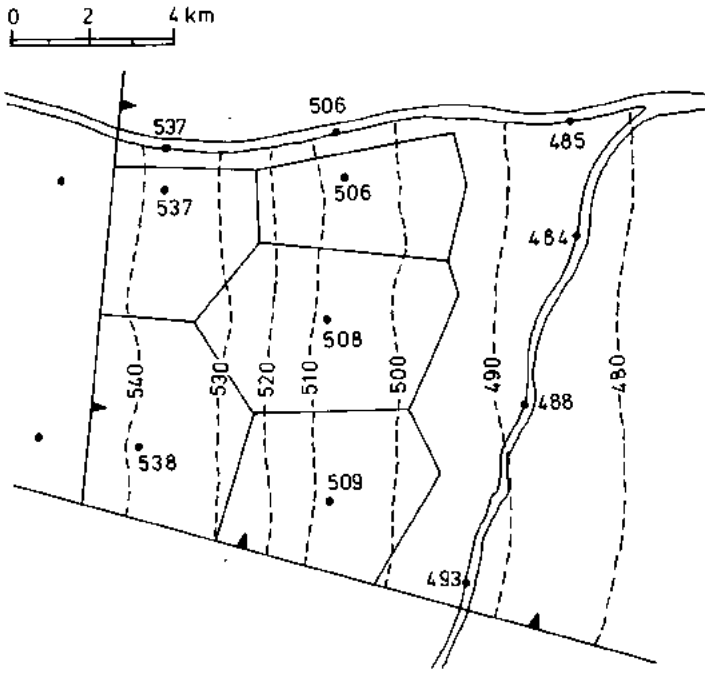

Fig. 5.6 Network superimposed on the contour map of the surface of the impermeable shale underlying the aquifer

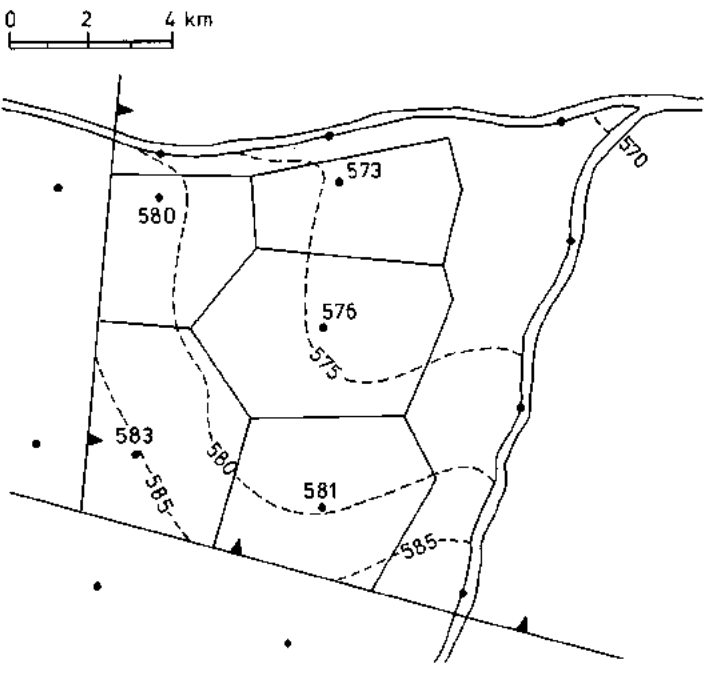

Fig. 5.7 Network superimposed on the topographical contour map

5.3.6 Initial conditions

As explained earlier, initial watertable elevations are needed for all internal and head-controlled nodes. To obtain these values, a watertable-contour map is made for the date on which the calculation process starts. This map is based on data from observation wells and/or piezometers and on water level data of the rivers. In our example we assume that the water levels of the external nodes in the rivers are fixed.

In Figure 5.8 the network is superimposed on the contour map of the initial watertable (HZERO), which shows lines of equal watertable elevation. These lines are used to determine a weighted mean watertable elevation for all nodal areas. The mean values in m above mean sea level are indicated at each node.

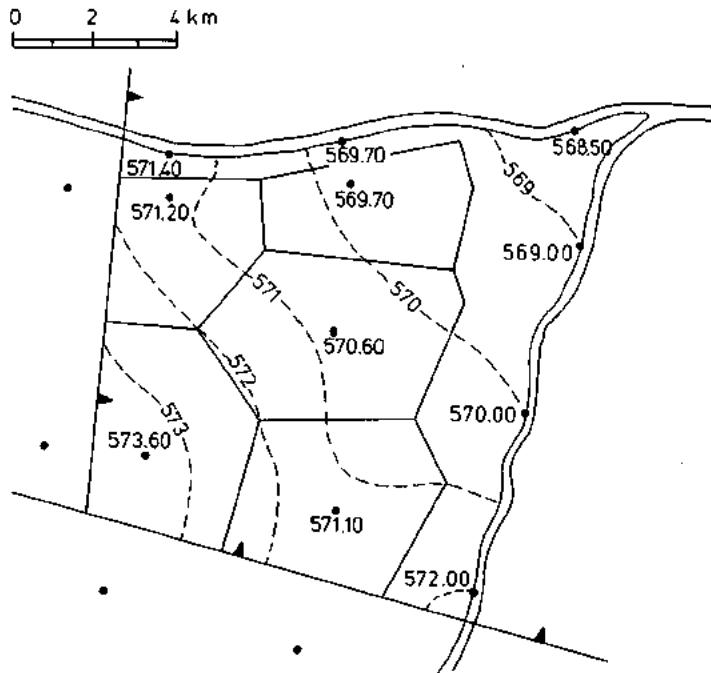

Fig. 5.8 Network superimposed on the initial watertable contour map (HZERO map)

5.3.7 Boundary conditions

Rain is the only source of groundwater recharge in the area. Rainfall data are available from a single meteorological station. Taking into account the size of the area and the fact that only one station exists in it, we shall assume that the rainfall is regularly distributed over the area. The portion of rain that reaches the groundwater, depends on several factors:

- the depth of the rainfall
- the slope of the area
- whether the area has a vegetative cover (trees, crops) or is barren land
- the infiltration capacity of the soil
- the soil moisture conditions of the unsaturated zone

Table 5.2 gives the monthly rainfall for the station and the corresponding deep percolation to the groundwater which we have estimated by assuming certain values for the different factors.

Table 5.2 Monthly rainfall and deep percolation, in mm

Rainfall	J	F	M	A	M	J	J	A	S	O	N	D	Total
	13	24	2	44	89	46	121	184	323	207	16	36	1105
Deep percolation													
	0	0	0	0	19	10	25	29	56	38	0	0	177

The entire valley bottom is used for agriculture. Supplementary irrigation is needed to grow two crops a year. To meet the water requirements, groundwater is pumped from wells which are scattered over the area. Their location, discharge, and time of operation are known. Table 5.3 shows the monthly groundwater abstractions from each nodal area.

Table 5.3 Monthly groundwater abstractions in million m³ in the Nodal Areas 1 to 5

Month	Nodal areas					Total
	1	2	3	4	5	
January	-0.38	-0.39	-1.20	-0.71	-0.62	-3.30
February	-0.36	-0.36	-1.15	-0.67	-0.57	-3.11
March	-0.25	-0.30	-0.89	-0.52	-0.40	-2.36
April	0	-0.11	-0.32	-0.19	-0.03	-0.65
May	+0.14	0	0	0	+0.18	+0.32
June	+0.14	0	0	0	+0.18	+0.32
July	+0.14	0	0	0	+0.18	+0.32
August	+0.14	0	0	0	+0.18	+0.32
September	+0.14	0	0	0	+0.18	+0.32
October	+0.14	0	0	0	+0.18	+0.32
November	-0.13	-0.21	-0.64	-0.37	-0.23	-1.58
December	-0.32	-0.36	-1.07	-0.62	-0.52	-2.89

Note: The abstractions of Nodes 1 and 5 have been adjusted for the lateral groundwater inflow across the N-S fault. It is assumed that this inflow (15 l/s per km length of the fault) is constant. For Nodes 1 and 5 this corresponds to 0.14 and 0.18 million m³ per month, respectively. The net abstraction in these nodes is the algebraic sum of the real abstraction and the groundwater inflow.

The area has three types of boundary conditions, viz. zero-flow, flow-controlled, and head-controlled. Because the hydraulic conductivity for zero-flow and flow-controlled boundaries is set equal to zero, the only watertable elevations that need to be prescribed are those for the head-controlled boundaries. The nodal network (Fig. 5.3) has six external nodes that simulate head-controlled boundaries, viz. Nodes 6, 7, 8, 9, 10, and 11. Table 5.4 shows the values of these external water levels, which are kept constant.

Note: The user should be aware of the special problems that a low-flow river may pose when used as a head-controlled boundary. If water is to be abstracted from wells in its neighbourhood, the river may dry up without the model noticing it. Another, infinite source will then act as boundary. A second problem is that rivers may have a low-permeability bed, increasing their radial resistance to groundwater flow and restricting recharge (see Chap. 6. Sect. 2.2).

Table 5.4 Data of water levels at head-controlled boundaries (m above m.s.l.)

Month	External node no.									
	6	7	8	9	10	11	12	13	14	15
January	571.4	569.7	568.5	569.0	570.0	572.0	-	-	-	-
February	571.4	569.7	568.5	569.0	570.0	572.0	-	-	-	-
March	571.4	569.7	568.5	569.0	570.0	572.0	-	-	-	-
April	571.4	569.7	568.5	569.0	570.0	572.0	-	-	-	-
May	571.4	569.7	568.5	569.0	570.0	572.0	-	-	-	-
June	571.4	569.7	568.5	569.0	570.0	572.0	-	-	-	-
July	571.4	569.7	568.5	569.0	570.0	572.0	-	-	-	-
August	571.4	569.7	568.5	569.0	570.0	572.0	-	-	-	-
September	571.4	569.7	568.5	569.0	570.0	572.0	-	-	-	-
October	571.4	569.7	568.5	569.0	570.0	572.0	-	-	-	-
November	571.4	569.7	568.5	569.0	570.0	572.0	-	-	-	-
December	571.4	569.7	568.5	569.0	570.0	572.0	-	-	-	-

5.3.8 Historical watertable elevations

For the five internal nodes of the network, monthly watertable elevations have been derived. Table 5.5 shows these data. This table is needed in the calibration phase when the calculated watertable elevations are compared with the historical ones.

Table 5.5 Data of historical watertable elevations (m above m.s.l.)

Month	Internal node no.				
	1	2	3	4	5
January	571.58	569.64	570.38	570.78	573.00
February	571.30	569.62	570.16	570.49	572.48
March	571.10	569.66	570.09	570.32	572.22
April	571.03	569.71	570.02	570.26	572.26
May	571.08	569.88	570.06	570.52	572.37
June	571.13	570.00	570.12	570.63	572.69
July	571.24	570.16	570.23	570.99	573.04
August	571.32	570.33	570.40	571.17	573.41
September	571.53	570.57	570.45	571.65	573.83
October	571.68	570.72	570.42	571.88	574.25
November	571.37	570.59	570.34	571.77	573.86
December	571.14	569.28	570.21	571.43	573.54

5.3.9. Groundwater balance

Prior to modelling a groundwater basin, one must assess an overall groundwater balance of the basin. In the calibration process, some of the flow components of the groundwater balance can be compared with the corresponding flow components calculated by the computer (e.g. total surface water outflow, change in groundwater storage).

In our example, the annual groundwater balance reads as follows:

<u>Input</u>		<u>Output</u>	
Recharge from rain	13,735,200 m ³	Abstraction by wells	15,810,000 m ³
Inflow through N-S fault	3,840,000	Groundwater outflow	2,113,300
	<u>17,575,200 m³</u>	Change in storage	<u>- 0,348,100</u>
			17,575,200 m ³

5.3.10 Other input data

The use of SGMP means that the calculation process is a Gauss-Seidel iteration method. To terminate the iterations, a tolerance level must be prescribed. The value of the annual recharge from rain - being the only external flow in the variable RECH(K) - is used as a yardstick and 10 per cent of this value is taken as an initial estimate. Because the unit for volume is one million cubic metres and the unit for time is one month, ERROR is equal to 0.114.

For the relaxation coefficient we take the value of 1 and for DELQ the value of 0.1, in conformity with the previously given guidelines.

For SGMP 2, four external switches must be prescribed. LSW3 is equal to 2, because the boundary conditions are available on a monthly basis and because DELTA=1 and MINOR=1. LSW4 is equal to 2, because we start with the calibration process. LSW5 is equal to 1, because we use a fixed time step of one month. For LSW6 no specific value needs to be given, because the aquifer is not semi-confined.

For SGMP 3^a three external switches must be prescribed. As we want to have the calculated watertable elevations and groundwater balances printed for each month, the values for LSW7 and LSW8 are both equal to 1. LSW9 is equal to 2, because it is the first run and we want to check the values of the head-controlled boundaries.

For SGMP 3^b three external switches must be prescribed. LSW9 is made equal to 1, because in SCMP 3^a the values of the head-controlled boundaries will be printed, so we do not need a plot of them. LSW10 is made equal to 1, because we have historical watertable elevations available. Finally LSW11 is made equal to 1, because we want to calculate the deviations between historical and calculated watertable elevations.

5.4 Transfer of data

The preparation of data as discussed in Section 5.3 resulted in a number of maps, a number of tables, and a number of single values. To transfer these data to computer cards, one first prepares a number of tables, as will be explained below.

5.4.1 Preparation of Data Set I

The parameters assigned to the nodes are represented by their node numbers. Table 5.6 lists the data assigned to both internal and external nodes; the data are taken from Figure 5.6 and Table 5.1.

Table 5.6 Parameters assigned to internal and external nodes

Number of node K	BL(K)	CO(K,1) (x-coordinate)	CO(K,2) (y-coordinate)
1	537	4.45	12.55
2	506	8.80	12.80
3	508	8.35	9.25
4	509	8.35	4.90
5	538	3.75	6.30
6	537	4.50	13.55
7	506	8.60	13.90
8	485	14.20	14.15
9	484	14.40	11.30
10	488	13.15	7.20
11	493	11.75	2.80
12	-	7.35	1.55
13	-	2.75	3.00
14	-	1.35	6.55
15	-	2.05	12.80

Table 5.7 lists the data assigned to the internal nodes only; the data are taken from Figures 5.5 and 5.7 and Table 5.1.

Table 5.7 Parameters assigned to internal nodes only

Number of node	SL(K)	NSIDE(K)	CO(K,1) specific yield	UL(K)*	OL(K)*
1	580	5	0.18	-	-
2	573	5	0.20	-	-
3	576	6	0.18	-	-
4	581	5	0.14	-	-
5	583	5	0.07	-	-

* Note: If switch LSW2 is equal to 1, specific values for UL(K) and OL(K) are needed in Columns 5 and 6.

Note: If some of the nodes in the network are denoted as semi-confined and/or confined, another table is needed (Table 5.8).

Table 5.8 Parameters for semi-confined and/or confined aquifers

Number of node	PCONF(I)	ASC(I)	CO(I,2) (thickness aquifer)
1	-	-	-
2	-	-	-
3	-	-	-
4	-	-	-
5	-	-	-

The parameters assigned to the sides of the nodal areas are more difficult to represent than those of the nodes. A special table is needed to represent the hydraulic conductivity PERM(J). First an auxiliary table is made (Table 5.9). Its first column lists the numbers of the internal nodes. Its second and following columns list the nodes that surround each of the nodes in Column 1. One starts with an arbitrarily chosen surrounding node and then continues with the others, moving in a *clock-wise* direction. The process is repeated for all the other internal nodes.

Table 5.9 Numbering system of the nodal network

Number of node (K)	Number of internal and external nodes surrounding node (K)				
1	6	2	3	5	15
2	7	8	9	3	1
3	2	9	10	4	5
4	3	10	11	12	5
5	1	3	4	13	14

Table 5.10 can now be compiled from Table 5.9 and Figure 5.4. Column 1 again lists the numbers of the internal nodes. The even-numbered columns list the surrounding nodes, and the odd-numbered columns, starting with Column 3, list the values of the hydraulic conductivity between the nodes of Column 1 and the surrounding nodes listed in the preceding even-numbered column. For example, the hydraulic conductivity of the side separating Nodes 1 and 6 is 70.

Table 5.10 Parameter assigned to the sides of the nodal areas

1	2	3	4	5	6	7	8	9	10	11	12	13
1	6	70	2	60	3	45	5	25	15	0	-	-
2	7	62	8	50	9	48	3	60	1	60	-	-
3	2	60	9	48	10	52	4	43	5	28	1	45
4	3	43	10	65	11	70	12	0	5	15	-	-
5	1	25	3	28	4	15	13	0	14	0	-	-

5.4.2 Sequence of cards and data formats in Data Set I

Table 5.11 shows the input sequence and data formats of the data cards in Data Set I.

Table 5.11 Card structure of Data Set I

Card No.	Name	Format
1	TITLE	20A4/20A4
2	NN, NSCONF, NCONF, NEXTN	4I4
3	NSIDE(K), K=1,NN	40I2
4	(CO(I,J), J=1,2), I=1,TNN	16F5.2
5	TMBAS, DMTIM, T, SCALE, LSW1	2A4,2F4.1,F8.0, I4
6	DELTA, MINOR, MAJOR, LIST	F4.2,3I4
7	ERROR, COEFFA	2F8.2
8	BL(K), K=1,TNN	20F4.0
9	K, (NS(J), PERM(J), J=1,J2)	I3,7x,7(I3, F5.2, 2x)
10	CO(I,1), I=1,NN	11F7.5
11	PCONF(K), K=1,NSCONF	10F8.4
12	ASC(I), I=1,NSCONF	11F7.5
13	SL(K), K=1,NN	20F4.0
14	CO(I,2), I=1,NCONF	20F4.0
15	LSW2, DELQ	I4,F4.1
16	UL(K), K=1,NN	10F8.4
17	OL(K), K=1,NN	10F8.4

The details are:

- Card 1 : Any name or sentence; total number of cards is 2.
- Card 2 : For actual values, see Section 5.3.1.
- Card 3 : The values of Column 3 of Table 5.7 are punched on this card, 40 values on each card. Total number of cards is $NN/40$.
- Card 4 : The values of Columns 3 and 4 of Table 5.6 are punched on this card; for each node, first the x-coordinate and then the y-coordinate, 16 values on each card. Total number of cards is $2 \times TNN/16$.
- Card 5 : For actual values, see Section 5.3.2.
- Card 6 : For actual values, see Section 5.3.3.
- Card 7 : For actual values, see Section 5.3.10.
- Card 8 : The values of Column 2 of Table 5.6 are punched on this card, 20 values on each card. Total number of cards is $TNN/20$.
- Card 9 : The values of Table 5.10 are punched on this card, each row on one card. Total number of cards is equal to NN .
- Card 10 : The values of Column 4 of Table 5.7 are punched on this card, 11 values on each card. Total number of cards is $NN/11$.
- Card 11 : If $NSCONF$ is not equal to zero, the values of Column 2 of Table 5.8 are punched on this card, 10 values on each card. Total number of cards is $NSCONF/10$.
If $NSCONF$ is equal to zero, skip Cards 11.
- Card 12 : If $NSCONF$ is not equal to zero, the values of Column 3 of Table 5.8 are punched on this card, 11 values on each card. Total number of cards is $NN/11$.
If $NSCONF$ is equal to zero, skip Cards 12.
- Card 13 : The values of Column 2 of Table 5.7 are punched on this card, 20 values on each card. Total number of cards is $NN/20$.
- Card 14 : If $NSCONF$ or $NCONF$ is not equal to zero, the values of Column 4 of Table 5.8 are punched on this card, 20 values on each card. Total number of cards is $(NSCONF + NCONF)/20$.
If both $NSCONF$ and $NCONF$ are equal to zero, skip Cards 14.
- Card 15 : For actual values, see Sections 5.3.5 and 5.3.10.
- Card 16 : If $LSW2$ is equal to 1, the values of Column 5 of Table 5.7 are punched on this card, 10 values on each card. Total number of cards is $NN/10$.

If LSW2 is equal to 2, skip Cards 16.

Card 17 : If LSW2 is equal to 1, the values of Column 6 of Table 5.7 are punched on this card, 10 values on each card. Total number of cards is $NN/10$.

If LSW2 is equal to 2, skip Cards 17.

A special form is used to facilitate the punching of the data cards; it is divided into 80 columns, which correspond with the 80 columns on a computer card (for more information, see Appendix 2). Figure 5.9 shows such a form. Its values have been written in accordance with the formats given in Table 5.11. The values correspond with the data of the hypothetical example.

When the form has been completed, the cards can be punched and Data Set I is ready.

Figure 5.10 shows part of the numerical output of Data Set I. It gives a reformatted playback of the general input, the distance between adjacent nodes (LENGTH), the length of the sides of the nodal areas, characterized by two node numbers (WIDTH), and the areas of the nodal areas.

5.4.3 Preparation of Data Set II

To transfer the data to computer cards, four tables are prepared:

Table 5.12 contains the data of the initial watertable elevations at each node, and the data of the initial watertable elevations of the confining layer for those nodes denoted as semi-confined. As our hypothetical example is part of an unconfined aquifer, Table 5.12 is compiled from Figure 5.8.

2880 Sustaining data handling of the standard groundwater model package (55MP)															
5	6	5	5	0	10										
445	1255	880	1280	835	925	835	490	375	630	450	1355	860	1390	1420	1415
1	2	3	4	5	6	7	8	9	10	11	12	13	14	15	16
1440	1130	1315	720	1175	280	735	155	275	300	135	655	205	1280		
month	305	80	100000	1											
1	1	12	1												
0	114	110													
537	506	508	509	538	537	506	485	484	488	493	0	0	0	0	0
1	2	3	4	5	6	7	8	9	10	11	12	13	14	15	16
1	670	2	60	3	45	5	25	3	60	15	0				
2	762	8	50	9	48	3	60	4	43	5	28			1	45
3	260	9	48	10	52	11	70	12	0	5	15				
4	343	10	65	11	70	12	0	13	0	14	0				
5	125	3	28	4	15										
18	20	18	14												
580	573	576	581	583											
2	1														

Fig. 5.9 Completed form for Data Set I

GROUNDWATERMODEL FOR ILLUSTRATING DATA HANDLING OF THE STANDARD GROUNDWATER MODEL PACKAGE(SGMP)

NUMBER OF INTERNAL NODES IS 5
 NUMBER OF EXTERNAL NODES IS 10

NUMBER OF SEMICONFINED NODAL AREAS IS 0
 NUMBER OF CONFINED NODAL AREAS IS 0
 NUMBER OF UNCONFINED NODAL AREAS IS 5

UNIT LENGTH : 1 METRE
 UNIT AREA : 1,000,000 SQ.METRES
 UNIT VOLUME : 1,000,000 CU.METRES

UNIT OF TIME FOR DELTA AND BOUNDARY CONDITIONS IS MONTH

156

BETWEEN NODE	PERMEABILITY SQ.M/DAY/M	WIDTH CM	LENGTH CM	NODE NO.	X-COORD. CM	Y-COORD. CM	BOTTOM ELEVATION
1 AND 6	70.00	3.32	1.80	1	4.45	12.55	537.
1 AND 2	60.00	1.68	4.36	2	8.80	12.80	506.
1 AND 3	45.00	2.55	5.11	3	8.35	9.25	508.
1 AND 5	25.00	2.15	6.29	4	8.35	4.90	509.
1 AND 15	0.00	3.37	2.41	5	3.75	6.30	530.
2 AND 7	62.00	4.88	1.12	6	4.50	13.55	537.
2 AND 8	50.00	1.34	5.57	7	8.80	13.90	506.
2 AND 9	48.00	1.92	5.88	8	14.20	14.15	485.
2 AND 3	60.00	4.57	3.58	9	14.40	11.50	484.
2 AND 1	60.00	1.71	4.56	10	13.15	7.20	486.
3 AND 2	60.00	4.57	3.58	11	11.75	2.80	493.
3 AND 9	48.00	0.78	6.39	12	7.35	1.55	0.
3 AND 10	52.00	3.12	5.22	13	2.75	3.80	0.
3 AND 4	43.00	3.76	4.35	14	1.35	6.55	0.
3 AND 5	20.00	2.66	5.40	15	2.65	12.80	0.
3 AND 1	45.00	2.55	5.11				
4 AND 3	43.00	3.76	4.35				
4 AND 10	65.00	1.60	5.32				
4 AND 11	70.00	3.15	4.00				
4 AND 12	0.00	4.81	3.50				
4 AND 5	15.00	3.30	4.81				
5 AND 1	25.00	2.20	6.20				
5 AND 3	28.00	2.66	5.46				
5 AND 4	15.00	3.26	4.81				
5 AND 13	0.00	3.30	3.45				
5 AND 14	0.00	4.80	2.41				

Fig. 5.10 Part of the output of SGMP 1

Table 5.12 Initial conditions at time T=0

Number of node	H(K)	HCONF(K)
1	571.20	-
2	569.70	-
3	570.60	-
4	571.10	-
5	573.60	-
6	571.40	-
7	569.70	-
8	568.50	-
9	569.00	-
10	570.00	-
11	572.00	-
12	-	-
13	-	-
14	-	-
15	-	-

Note: Of the external nodes, only those simulating head-controlled boundaries (Nodes 6, 7, 8, 9, 10, and 11) require a value of H(K). For purely flow-controlled boundaries, there is no need to specify H(K) because the boundaries facing these external nodes are assumed to be impermeable and their hydraulic conductivity values are therefore zero.

Table 5.13 contains the data of RECH(K), representing the deep percolation from rainfall.

The columns are headed by the numbers of the internal nodes. The rows contain the values of RECH(K), either for each time step DELTA or for each first or second accumulation level, depending on the value assigned to LSW3. The total number of rows also depends on LSW3:

- for LSW3 equal to 1: LIST rows
- for LSW3 equal to 2: LIST × MAJOR rows
- for LSW3 equal to 3: LIST × MAJOR × MINOR rows

For our hypothetical example, Table 5.13 is compiled from Table 5.2 (LIST=1, MAJOR=12, MINOR=1, LSW3=2).

Table 5.13 Data of RECH(K)

Number of first accumulation level (month)	Internal node no.				
	1	2	3	4	5
1	0	0	0	0	0
2	0	0	0	0	0
3	0	0	0	0	0
4	0	0	0	0	0
5	0.019	0.019	0.019	0.019	0.019
6	0.010	0.010	0.010	0.010	0.010
7	0.025	0.025	0.025	0.025	0.025
8	0.029	0.029	0.029	0.029	0.029
9	0.056	0.056	0.056	0.056	0.056
10	0.038	0.038	0.038	0.038	0.038
11	0	0	0	0	0
12	0	0	0	0	0

Table 5.14 contains the data of FLWCON(K), representing the algebraic sum of the abstraction by pumped wells and the groundwater flow through flow-controlled boundaries. This table is compiled from Table 5.3 and is set out in the same way as Table 5.13.

Table 5.14 Data of FLWCON(K)

Number of first accumulation level (month)	Internal node no.				
	1	2	3	4	5
1	-0.38	-0.39	-1.20	-0.71	-0.62
2	-0.36	-0.36	-1.15	-0.67	-0.57
3	-0.25	-0.30	-0.89	-0.52	-0.40
4	0	-0.11	-0.32	-0.19	+0.03
5	+0.14	0	0	0	+0.18
6	+0.14	0	0	0	+0.18
7	+0.14	0	0	0	+0.18
8	+0.14	0	0	0	+0.18
9	+0.14	0	0	0	+0.18
10	+0.14	0	0	0	+0.18
11	-0.13	-0.21	-0.64	-0.37	-0.23
12	-0.32	-0.36	-1.07	-0.62	-0.52

Note: If the values of RECH(K) and FLWCON(K) are available on a monthly basis and TMBAS is made equal to one week, these values must be entered in

Tables 5.14 and 5.15 on the time basis of one *week*; in other words, the original data must be divided by four.

Table 5.15 contains the watertable elevations for those external nodes that simulate head-controlled boundaries. It is compiled from Table 5.4.

Table 5.15 Data of head-controlled boundaries

Number of first accumulation level (month)	External node no.									
	6	7	8	9	10	11	12	13	14	15
1	571.4	569.7	568.5	569.0	570.0	572.0	-	-	-	-
2	571.4	569.7	568.5	569.0	570.0	572.0	-	-	-	-
3	571.4	569.7	568.5	569.0	570.0	572.0	-	-	-	-
4	571.4	569.7	568.5	569.0	570.0	572.0	-	-	-	-
5	571.4	569.7	568.5	569.0	570.0	572.0	-	-	-	-
6	571.4	569.7	568.5	569.0	570.0	572.0	-	-	-	-
7	571.4	569.7	568.5	569.0	570.0	572.0	-	-	-	-
8	571.4	569.7	568.5	569.0	570.0	572.0	-	-	-	-
9	571.4	569.7	568.5	569.0	570.0	572.0	-	-	-	-
10	571.4	569.7	568.5	569.0	570.0	572.0	-	-	-	-
11	571.4	569.7	568.5	569.0	570.0	572.0	-	-	-	-
12	571.4	569.7	568.5	569.0	570.0	572.0	-	-	-	-

5.4.4 Sequence of cards and data format in Data Set II

Table 5.16 shows the input sequence and data formats of the data cards in Data Set II.

Table 5.16 Card structure of Data Set II

Card No.	Name	Format
1	LSW3, LSW4, LSW5, LSW6	4I4
2	H(K), K=1,TNN	10F8.2
3	HCONF(K), K=1,NSCONF	10F8.2
4	RECH(K), K=1,NN	8x,14F5.3
5	FLWCON(K), K=1,NN	8x,7F10.4
6	H(K), K=NO,TNN	8x,9F8.2
7	DELTA	F6.4

The details are:

- Card 1 : For actual values, see Section 5.3.10.
- Card 2 : The values of Column 2 of Table 5.12 are punched on this card. Each card contains 10 values. Total number of cards is $TNN/10$.
- Card 3 : The values of Column 3 of Table 5.12 are punched on this card. Each card contains 10 values. Total number of cards is $NCONF/10$. If $NCONF$ equals zero, skip Card 3.
- Card 4 : The first 8 columns are reserved for identification (see below). The values of the first row of Table 5.13 are punched on this card, except the one in Column 1. Each card contains 14 values. Total number of cards is $NN/14$.
- Card 5 : The first 8 columns are reserved for identification (see below). The values of the first row of Table 5.14 are punched on this card, except the one in Column 1. Each card contains 7 values. Total number of cards is $NN/7$.
- Card 6 : The first 8 columns are reserved for identification (see below). The values of the first row of Table 5.15 are punched on this card, except the one in Column 1. Each card contains 9 values. Total number of cards is $NEXTN/9$.
- Card 7 : Values of DELTA. If $LSW5$ is equal to 1, skip Card 7; the calculation is then made with a constant time step DELTA read from SGMP 1.

Note: Because $LSW3$ is made equal to 2, Cards 4, 5, and 6 are repeated $LIST \times MAJOR$ times. In the second set of these cards, the values of the second row of Tables 5.13, 5.14, and 5.15 are punched; in the third set the values of the third row, and so on.

Depending on the total number of time steps for which the boundary conditions are available and on the number of internal nodes in the network, Data Set II may contain a great number of data cards. To facilitate the identification of specific cards, the first 8 columns of Cards 4, 5, and 6 are reserved for identification, indicating, for example, the name of the variable, run-number, number of time step.

Figure 5.11 shows the form completed for Data Set II. Its values have been written in accordance with the formats given in Table 5.16. When the cards have been punched, Data Set II is ready.

With Data Sets I and II, the calculations can be made. There is still no output, however, because it is stored on a file (FILE 2).

5.4.5 Preparation of Data Set III

As the required data are read from a file (FILE 2), Data Set III only requires the values of three external switches with which the user can choose what kind of data he wants printed and in what detail. Data Set III requires only one card. Its data format is shown in Table 5.17. For the actual values of the three switches, see Section 5.3.10.

Table 5.17 Card structure of Data Set III

Card No.	Name	Format
1	LSW7, LSW8, LSW9	3I4

Figure 5.12 shows part of the output of SGMP 3^a. Note that both the watertable elevations and the groundwater balance are printed for each time step of one month and that the values at the external nodes are also printed.

5.4.6 Preparation of Data Set IV

To transfer the data to computer cards, one table, Table 5.18 is prepared. It contains the historical watertable elevations at the five internal nodes, and is compiled from Table 5.5.

T = 1.0000 NO. OF ITERATIONS = 2 NO. OF SUBITERATIONS = 0

NODE NO. 1 H UNCONF # 571.9317
 NODE NO. 2 H UNCONF # 569.5001
 NODE NO. 3 H UNCONF # 570.2095
 NODE NO. 4 H UNCONF # 570.5408
 NODE NO. 5 H UNCONF # 572.9792
 NODE NO. 6 H UNCONF # 571.4000
 NODE NO. 7 H UNCONF # 569.7500
 NODE NO. 8 H UNCONF # 568.5000
 NODE NO. 9 H UNCONF # 569.0000
 NODE NO. 10 H UNCONF # 570.0000
 NODE NO. 11 H UNCONF # 572.0000
 NODE NO. 12 H UNCONF # 0.0000
 NODE NO. 13 H UNCONF # 0.0000
 NODE NO. 14 H UNCONF # 0.0000
 NODE NO. 15 H UNCONF # 0.0000

WATERBALANCE COMPONENTS

NODE	RECHARGE	CHANGE IN STORAGE IN TOPLAYER	SEEPAGE FLOW	CHANGE IN STORAGE IN AQUIFER	TOTAL SUBSURFACE FLOW	PUMP FLOW	DRAINAGE FLOW
1	0.0000	0.0000	0.0000	0.3303	0.0304	-0.3000	0.0000
2	0.0000	0.0000	0.0000	0.2026	0.1393	-0.3000	0.0000
3	0.0000	0.0000	0.0000	1.1023	-0.0160	-1.2000	0.0000
4	0.0000	0.0000	0.0000	0.5114	0.0882	-0.7100	0.0000
5	0.0000	0.0000	0.0000	0.7253	-0.1049	-0.6200	0.0000

WATERBALANCE COMPONENTS FOR HOLE B SIN

0.0000	0.0000	0.0000	3.0518	0.1369	-3.3000	0.0000
--------	--------	--------	--------	--------	---------	--------

T = 2.0000 NO. OF ITERATIONS = 2 NO. OF SUBITERATIONS = 0

NODE NO. 1 H UNCONF # 570.8847
 NODE NO. 2 H UNCONF # 569.5183
 NODE NO. 3 H UNCONF # 569.9091
 NODE NO. 4 H UNCONF # 570.0192
 NODE NO. 5 H UNCONF # 572.4141
 NODE NO. 6 H UNCONF # 571.4000
 NODE NO. 7 H UNCONF # 569.7000
 NODE NO. 8 H UNCONF # 568.5000
 NODE NO. 9 H UNCONF # 569.0000

Fig. 5.12 Part of the output of SGMP 3a

Table 5.18 Data of historical watertable elevations

No. of first accumulation level (month)	Internal node no.				
	1	2	3	4	5
1	571.58	569.64	570.38	570.78	573.00
2	571.30	569.62	570.16	570.49	572.48
3	571.10	569.66	570.09	570.32	572.22
4	571.03	569.71	570.02	570.26	572.26
5	571.08	569.88	570.06	570.52	572.37
6	571.13	570.00	570.12	570.63	572.69
7	571.24	570.16	570.23	570.99	573.04
8	571.32	570.33	570.40	571.17	573.41
9	571.53	570.57	570.45	571.65	573.83
10	571.68	570.72	570.42	571.88	574.25
11	571.37	570.59	570.34	571.77	573.86
12	571.14	569.28	570.21	571.43	573.54

Table 5.19 shows the input sequence and data formats of the data cards in Data Set IV.

Table 5.19 Card structure of Data Set IV

Card No.	Name	Format
1	BLNK, HI, HMINUS, HX, ASTRSK, HY, PLUS, LSW9, LSW10, LSW11	7A4,3I2
2	MINOR, MAJOR, LIST	3I4
3	H(K,M), K=1,NN, M=1,MAJOR	8x,9F8.2

The details are:

- Card 1 : The signs BLNK, HI, HMINUS, HX, ASTRSK, HY, and PLUS are arbitrarily chosen; for actual values for LSW9, LSW10, and LSW11, see Section 5.3.10.
- Card 2 : The values of MINOR, MAJOR, and LIST are punched on this card. If LSW10 is equal to 1, skip Card 2.
- Card 3 : The first 8 columns are reserved for identification. The values of the first row of Table 5.18, except the one in Column 1, are

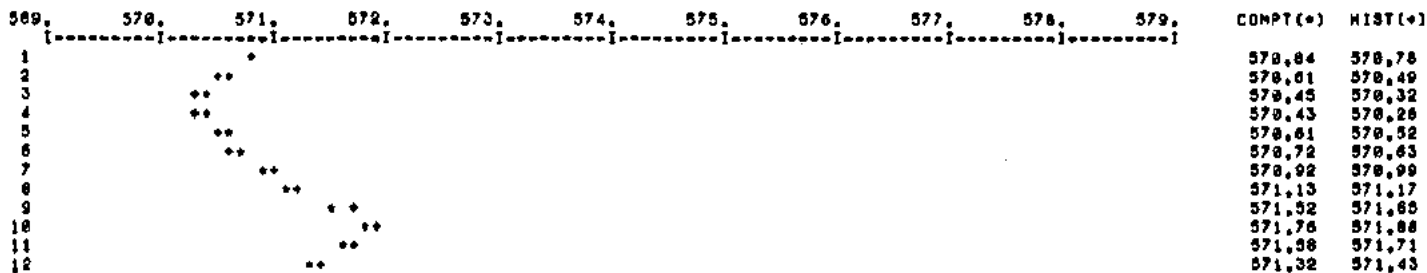

NODE NO 4 ELEVATIONS(METRES ABOVE SEALEVEL) VS, TIME(MONTH); SURFACE ELEVATION = 581.

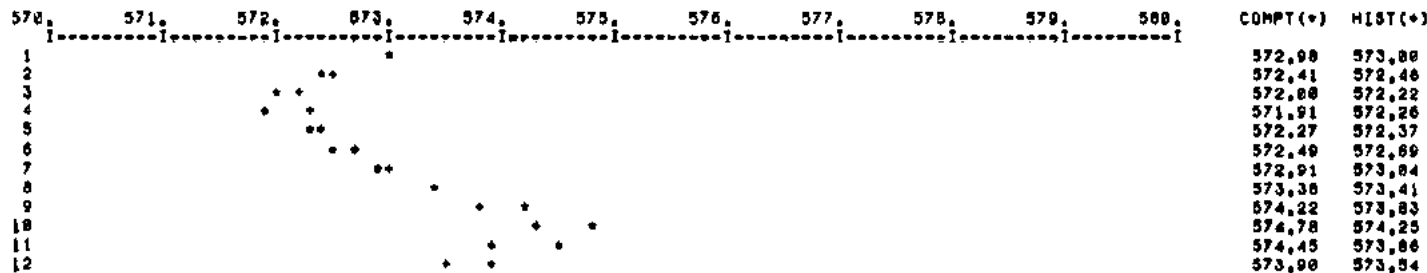

NODE NO 5 ELEVATIONS(METRES ABOVE SEALEVEL) VS, TIME(MONTH); SURFACE ELEVATION = 583.

CALCULATION OF DEVIATIONS BETWEEN CALCULATED AND HISTORICAL WATERTABLE ELEVATIONS

THIS CALCULATION IS BASED ON THE DEVIATIONS DYER ALL THE INTERNAL NODES AND TAKEN OVER 12 TIME STEPS;
TOTAL NUMBER OF TIME STEPS IN THE ENTIRE CALCULATION PERIOD IS 12

MEAN * 0,86 METER
STANDARD DEVIATION * 0,27 METER

167

Fig. 5.14 Part of the output of SGMP 3^b

6.1 Calibration

6.1.1 General

Before the model can perform its task of predicting the future watertable behaviour, it must be calibrated. This means that a check must be made to see whether the model can correctly generate the past behaviour of the watertable as it is known from historical records.

One starts the calibration procedure by selecting a period for which historical records are available. The relevant geological information and the historical data are then fed into the computer, which calculates a watertable elevation for each nodal point. These values are then compared with the watertable elevations as they are known from historical records. The comparison will usually reveal a discrepancy between the two.

As errors can obviously be made in the interpretation of geological information and as historical records may not be wholly reliable or may be incomplete, one is permitted to change the input parameters to a certain extent. One must re-evaluate the geological information and/or the historical records, which will yield a new set of input data for the model. A new run is made with this new set of data and new watertable elevations are calculated. These may fit the historical watertable elevations better (or possibly even worse) than the original set. This process of trial and error is repeated until the calculated values satisfactorily match the historical ones.

Depending on the desired accuracy and the difficulties experienced with scarcity of data, some ten to twenty runs may be needed to obtain a good fit. Goodness of fit, of course, is a relative idea but, in general, the permissible deviations between calculated and historical watertables are some tens of centimetres.

Obviously, the longer the period used for calibration, the better the results will be. This is particularly so for unconfined aquifers, which have a long natural response time (Rushton and Redshaw 1979). As long-term records of watertable elevations are seldom available, however, the model usually has to be calibrated with data covering only a relatively short period, which, if possible, should be so selected that extremes of watertable behaviour have occurred within it. The absolute minimum period, however, is two full years of data, the first year being used to adjust the input data and the second year serving as a check to see whether the adjustments were adequate. If not, the process is repeated.

Calibration is the most difficult part of groundwater modelling. It requires great skill and real teamwork on the part of all the people involved: the geologist who is providing data on transmissivities and storage coefficients, the irrigation engineer providing data on irrigation practices and losses, the hydrologist providing data on watertable behaviour and watertable elevations, and the others who are providing data on rainfall, evapotranspiration, runoff, and pumping rates. All these data must be brought together before a calibration run can be made.

The best way to act during calibration is to evaluate the results of a calibration run, propose certain adjustments in input parameters, and discuss these with the expert(s) in question. For fruitful cooperation, each expert should be aware that many of his figures are mere estimates and are thus liable to error.

It is stressed that each expert providing input parameters should indicate the possible range of errors in the values he is providing, preferably before the first calibration run is made. To be able to do this, he must have a sound judgement of the parameters in question and must know the extent to which their values can be varied over the tolerance to which they are known.

It may happen that some of the calculated watertable elevations cannot be matched with the historical ones, even if the values of the parameters have been varied up to their maximum error percentage. Faced with this situation, one has no alternative but to return to the field for additional measurements.

Proper model calibration depends above all else on the integrity of the calibrator. It is always possible to "calibrate" a model. When one has a "free hand" in changing the input parameters and disregards the maximum error limits, one can always get the calculated watertable elevations to match the historical ones. But then, one is not calibrating the model, one is merely playing with it, which is a dangerous game. A model calibrated in this way means that the computer replaces field work and the question then remains whether the model makes any hydrological sense. But, if the assumptions on which the model is based are satisfied, if certain of the input parameters have a good to fair degree of accuracy, and the model is properly calibrated on this basis, it can be a sound prediction tool on which to base decisions for the optimum use and management of a basin's groundwater resources.

6.1.2 Sources of error

Errors in input data can stem from two categories of sources:

- i) Errors in the physical properties of the aquifer:
 - type of aquifer
 - depth
 - permeability
 - storage coefficient/specific yield
 - watertable elevation
- ii) Errors in the hydrological stress exerted on the aquifer:
 - precipitation
 - seepage from or drainage to rivers
 - losses in the conveyance, distribution, and application of irrigation water
 - groundwater flow through flow-controlled boundaries

- tubewell abstraction
- capillary rise from a shallow watertable
- evapotranspiration

As this list shows, almost all input data are subject to error. The deviations between calculated and historical watertables will often be the result of a combination of errors. Unravelling the sources of error can best be done by examining each aquifer parameter and each hydrologic parameter separately. The most common errors will be discussed below.

Of course, errors can also be made in punching the data onto computer cards and it is advisable to first check whether any such errors have been made. One can do this in two ways: either by comparing the punched data with the data on the completed forms, or by making a computer run and comparing the printed data with the tables and lists prepared before completing the forms.

Transmissivity

Figure 6.1 shows the effect of a wrong estimate of the transmissivity between two nodes. For this and the following examples we used our hypothetical area described in Chapter 5. Its watertable-contour map shows that the groundwater flow is from Nodal Area 1 to Nodal Area 2. It is therefore obvious that the transmissivity at the side shared by these two areas has been assessed too low. This results in watertables that are too high in Nodal Area 1 and too low in Nodal Area 2, which is characteristic of this kind of error. Because the transmissivity T is the algebraic product of the saturated thickness D and the hydraulic conductivity K , the source of the error could be either in D or K or in both.

Storage coefficient (or specific yield)

Figure 6.2 shows the effect of too high an estimate of the storage coefficient in a nodal area.

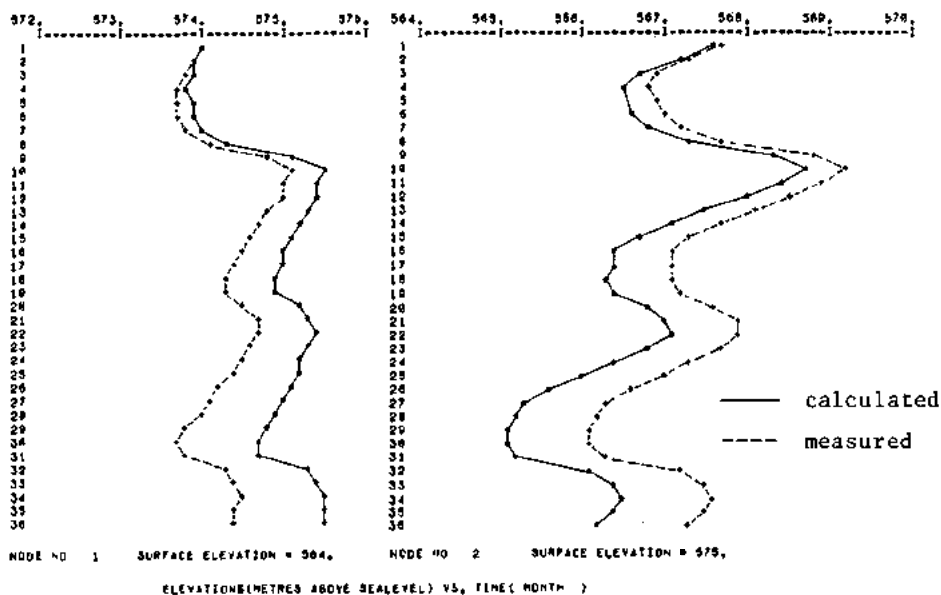

Fig. 6.1 Error in transmissivity

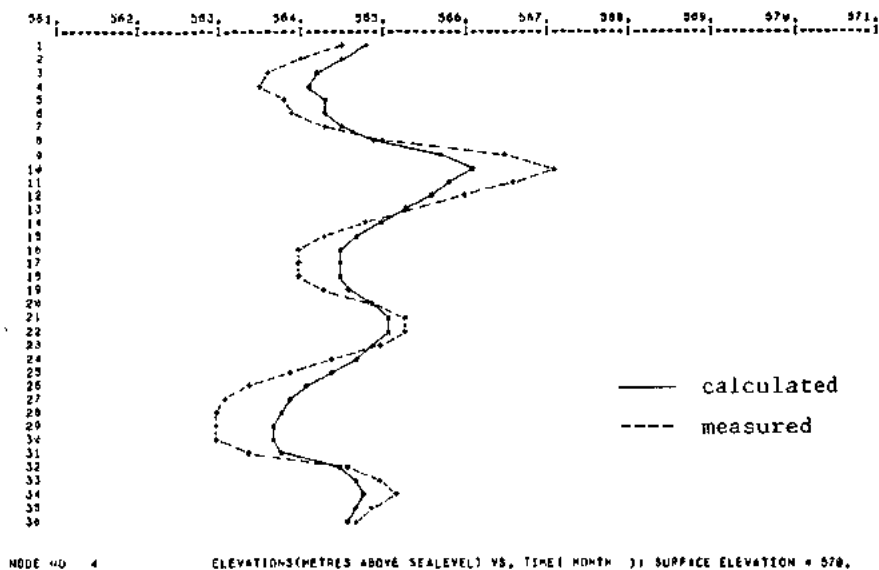

Fig. 6.2 Error in storage coefficient

For periodic fluctuations in the historical watertables, this results in amplitudes in the calculated watertables that are too small. For too low values of the storage coefficient, the amplitudes are too large.

Watertable elevation

Figure 6.3 shows the effect of an error in a nodal watertable elevation.

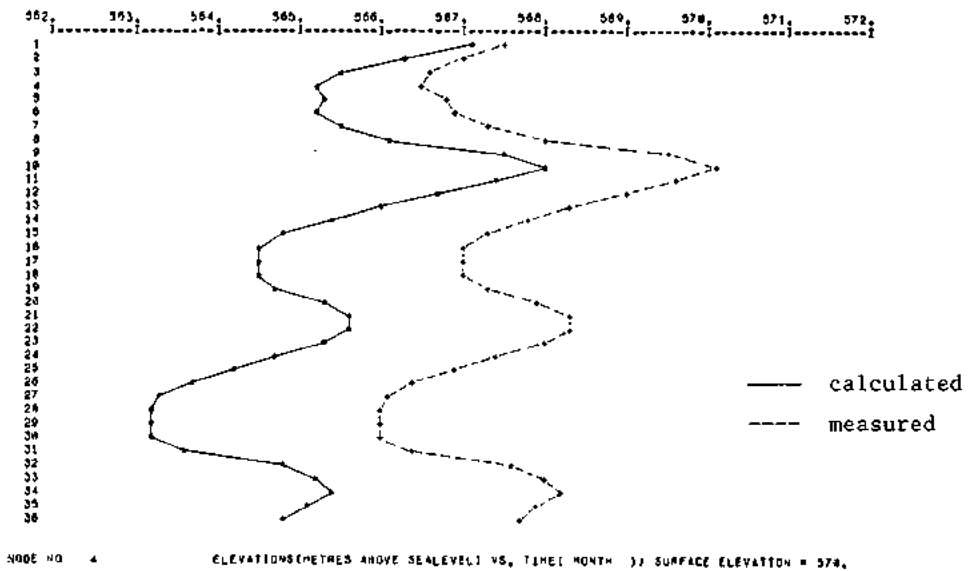

Fig. 6.3 Error in watertable elevation

In the field, groundwater levels are measured as a depth to the watertable, but the model requires absolute elevations above a datum. This means that the elevation of the rim of the well or a reference point in the well must be known from a levelling survey. This levelling is sometimes a great source of error, especially when the levelling survey is not performed in closed circuits or back and forth from a bench mark. Such mistakes may go unnoticed and the resulting errors can range from several metres to some tens of metres. Because the initial and consecutive historical watertables

are all affected in the same way, a result as shown in Figure 6.3 can be obtained. Because there was a levelling error of + 3 m in the elevation of the well, the initial watertable and all consecutive historical watertables are 3 m too high. Characteristic of this type of error is that in the beginning of the calculation period the deviations between calculated and historical watertable elevations increase steadily and later on become more or less constant. In this case, the deviations stabilized at 3 m difference.

Percolation or abstraction

Figure 6.4 shows the effects of errors in nodal net percolation and/or abstraction.

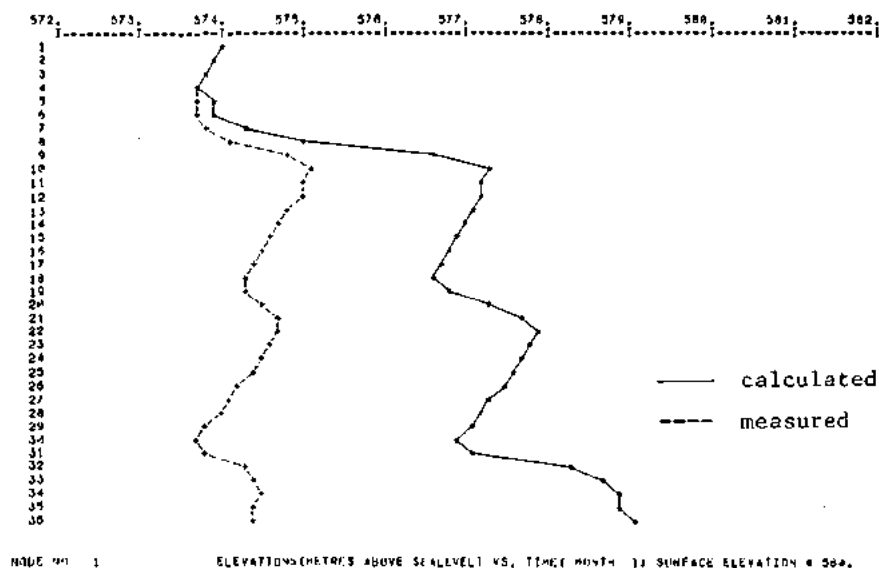

Fig. 6.4 Error in percolation or abstraction

These errors are often systematic. If, for example, irrigation field losses have been assessed too high, the watertables in all areas where irrigation is practised will be too high. Another possibility is that not all components influence the watertable constantly. As shown in Figure 6.4, for

instance, the abstraction was assessed reasonably well, but the percolation from precipitation was estimated too high. There was no percolation from rainfall in the first three months, so the calculated watertables match the historical ones in that period.

6.1.3 Calibration procedure

As deviations between calculated and historical watertables can be due either to errors in individual input parameters or to a combination of such errors, the problem one faces in changing input parameters is where to start and what to change.

The best place to start is in those nodal areas where the largest deviations occur. This is advised for two reasons. Firstly, if input data are changed in too many nodal areas at once, it will be difficult to see what the individual effects of these changes are. Secondly, deviations in a certain nodal area may well be the result of errors in input data of other nodal areas, whereas the input data for the nodal area itself are good.

Figure 6.5 gives an example.

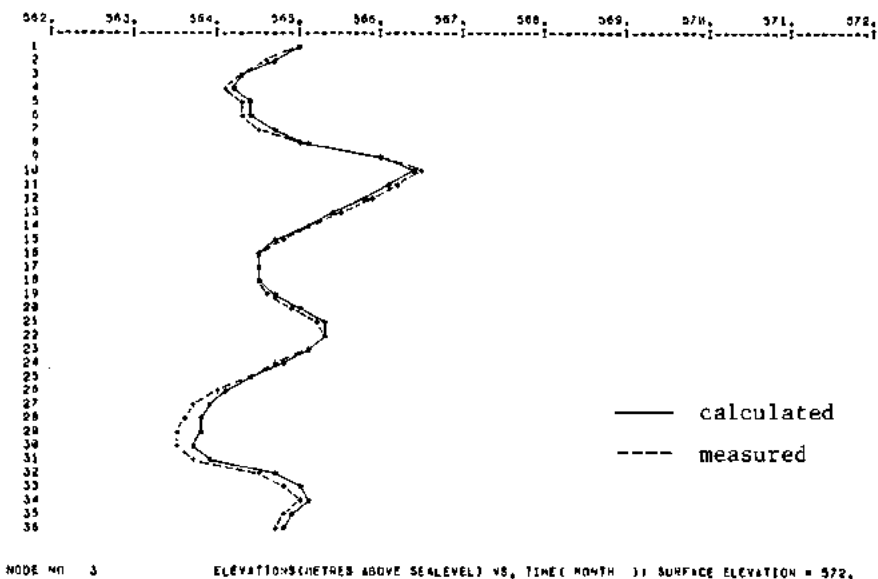

Fig. 6.5 Influence of one area on another

For the nodal area itself, the input data are correct, but the deviations are caused by an error in the storage coefficient in its neighbouring nodal areas. When this error is corrected, the problem in the nodal area no longer exists. One must always be on one's guard for errors of this kind, and must never forget that changing an input parameter in one nodal area will have an effect, either good or bad, in other nodal areas.

As to the question of what to change, there is no cut-and-dried answer; the problem is to detect which input parameter(s) is (are) causing the deviations. One begins by considering the four sources of error:

- errors in storage coefficient (S)
- errors in transmissivity (K or D)
- errors in percolation or/and abstraction (R or P)
- errors in watertable elevation (WE)

By making a sensitivity analysis of the first three categories, it may be possible to detect the sources of error. At the very least, a sensitivity analysis will reveal that a watertable is more sensitive to changes in one kind of input parameter than to changes in another. For example, from Figures 6.1, 6.2, and 6.4, in which the values of K (or D), S, and R (or P) were changed 100 per cent, it can be seen that the watertable reacts more sharply to changes in net recharge (R or P) than to changes in the geohydrological parameters (K, D, and S). Since this is true for most ground-water basins, it is sometimes possible to establish whether changes in the geohydrological parameters alone are sufficient to reduce deviations to within an acceptable range. To be able to do this, one must set upper and lower limits for each of these parameters. Suppose that there are deviations of more than 3 m and sensitivity runs have indicated that changing the geohydrological parameters up to their limits only results in changing the watertable by 2 m, this is clear evidence that changes must also be made in the net percolation and abstraction rates or watertable elevations, because there are obviously errors in these data.

The next step is to examine the pattern of deviation, as this can help in determining which of the input parameters is primarily causing the deviations. Figure 6.6 outlines a procedure that can be followed. It shows five possibilities.

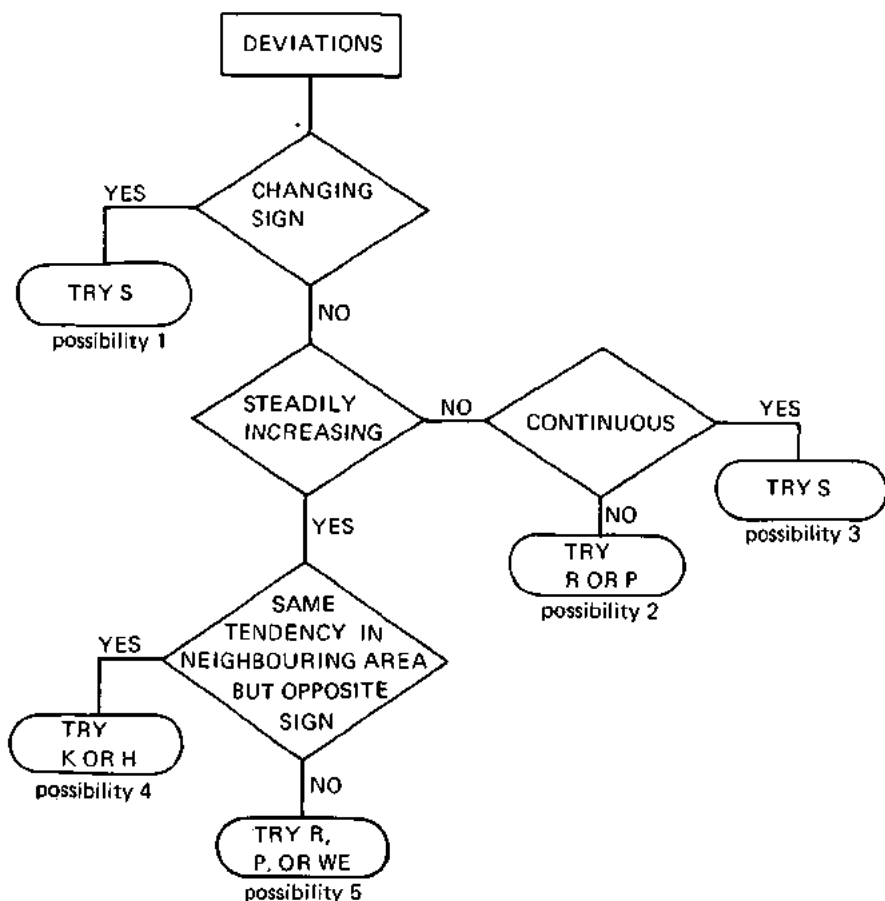

Fig. 6.6 Procedure for determining which input parameter(s) is (are) causing the deviation

Possibility 1 refers to a situation in which the historical watertable exhibits periodic fluctuations and the deviations keep changing in sign from positive to negative. The amplitude of the calculated watertable is then constantly greater or smaller than that of the historical watertable. Figure 6.2 gives an example.

Possibility 2 refers to calculated and historical watertables that match for a certain period, and then suddenly deviate. An example is shown in Figure 6.7. It is also possible that the calculated and historical water-

tables first deviate for a certain period and then suddenly match. In both cases there are obviously errors in the percolation and/or abstraction rates. An explanation of the second could be that during the initial period it was assumed that no irrigation took place, whereas in reality it did.

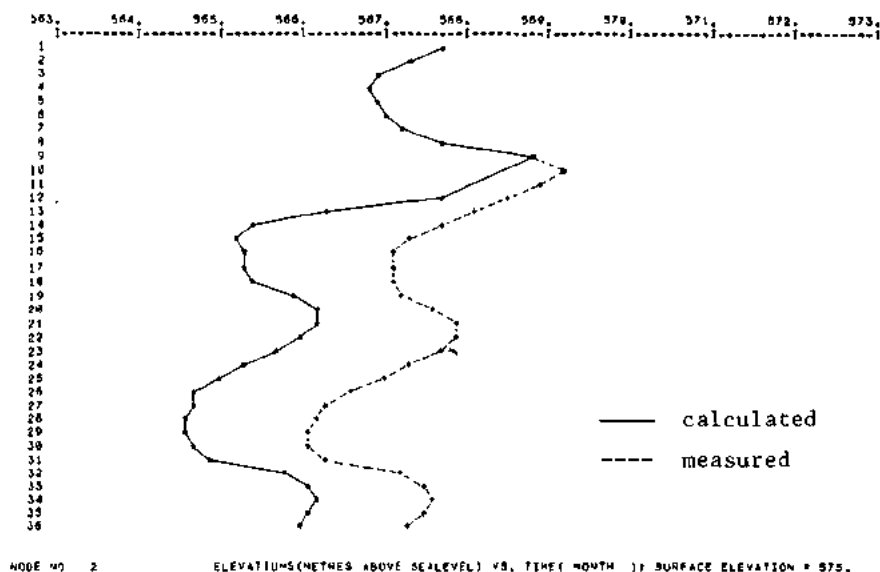

Fig. 6.7 Error in net deep percolation

Possibility 3 refers to deviations that do not necessarily change in sign, but vary in magnitude with time. This is illustrated in Figure 6.8. Here too, the best way to start is by changing the storage coefficient S .

Possibility 4 is clear; when two neighbouring nodal areas exhibit the same tendency in deviations, but with opposite signs, it is advisable to change the transmissivity at their common boundary (see also Fig. 6.1). In all other circumstances, changing the transmissivity will result in an improvement in one nodal area and a worsening in another. It is not advisable trying to change the percolation or abstraction rates in outputs as in Figure 6.1, because errors in net recharge are often systematic. This means that in both areas they are either too big or too small.

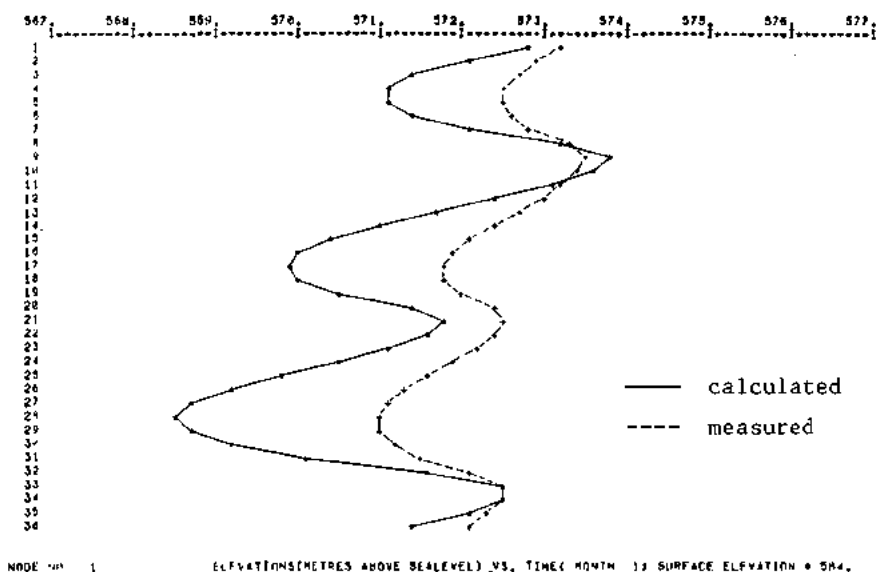

Fig. 6.8 Error in storage coefficient

Possibility 5 is the most difficult; it means that none of the previous possibilities were clearly relevant, so that the cause of the deviations must be sought in errors in net percolation and/or abstraction rates or errors in watertable elevations. When the calculated watertables are consistently too high or too low over the whole area or over a part of it, it is advisable to re-evaluate the net percolation and/or abstraction rates. When isolated deviations occur without any clear pattern, it is advisable to re-evaluate the levelling data in those areas.

The procedure outlined above is meant merely as a guideline; one will always face deviations occurring in a pattern that suggests that they are due to errors in one input parameter, whereas in reality they are due to a combination of errors. The procedure merely suggests which input parameter one might start with. In Figure 6.4, for instance, there may also be an error in the storage coefficient, but changing that parameter in an early stage will not improve the picture.

6.2 Production runs

6.2.1 General

So far, all the work of collecting the data, preparing the data sets, and calibrating the model has only allowed us to reconstruct the historical measured watertable elevations. But the true purpose of a model is to indicate what the long-term behaviour of the watertable would be if certain plans for the use of water were to be implemented. A "production run" is the term used when the model simulates future percolation and abstraction as if a certain development plan had already been implemented.

Such plans introduce either percolation or abstraction (or both) that is different from the percolation or abstraction in the past. A new irrigation scheme, for example, introduces additional percolation through irrigation losses and leaching practices, if any; a new pumping station for domestic water supplies or for irrigation introduces new, locally high, abstraction rates. A more complex situation is one in which an area is already being irrigated with water from a river but, since the river flows vary greatly, a plan is being drawn up to use groundwater as an auxiliary supply. Such a plan not only means rates of groundwater abstraction that will vary in accordance with the river flows but also new, additional percolation.

In complex situations like this, the model enables us to examine what consequences a certain development plan will have on the watertable. But - and this is the real strength of the model - it also allows us to study the consequences of a number of alternatives within the development plan. Possible alternatives are:

- whether irrigation canals should be lined or not
- which irrigation method should be applied
- what is the best site for a pumping station
- what are the effects of changes in the relative contribution of surface water and groundwater.

By simulating such alternatives, one can provide the decision-maker with a sound basis on which to select the most appropriate plan.

Each development plan or alternative within it can be "translated" into new, additional percolation and/or abstraction rates. These rates, super-

imposed on the actual rates, can be regarded as the assumed, future hydrological stress on the groundwater basin. Together with the values of the hydrogeological parameters that were found during the calibration process, they form the base of the data sets for production runs.

The period over which the model can simulate future conditions in production runs can be as long as one likes, although periods of twenty to forty years will suffice for most purposes. The advantage of such long-term simulation is that cycles of dry and wet years can be simulated, with groundwater mining in dry years and groundwater recharge in wet years (de Ridder and Erez 1977).

6.2.2 Data requirements

For production runs, our model requires Data Sets I, II, III, and/or IV. A brief description of each follows.

As Data Set I consists of data on the geometry of the nodal network and on the hydrogeological parameters of the aquifer, it is the same for production runs as it was after calibration, except for the parameters of time discretization. Because the percolation losses and abstraction rates will usually be prepared on a monthly basis (TMBAS is month), LIST denotes the number of years one wants to simulate, MAJOR is equal to 12 (denoting months), and MINOR and DELTA are equal to 1. If DELTA is chosen as 0.5, MINOR is then equal to 2.

As Data Sets III and IV consist only of external switches for printing or plotting the simulation results, they constitute no problem. The only difficulties that may arise are in Data Set II, which consists of three types of data:

- i) data on initial watertable elevations
- ii) data on percolation and abstraction rates
- iii) data on boundary conditions

i) Initial watertable elevations must be prescribed for all internal nodes and for any external nodes that are head-controlled. To obtain these elevations, one needs the most recently recorded data. One might, for in-

stance, use last year's records of observation wells and calculate from them the mean watertable elevations. These values, transposed to a watertable-contour map and superimposed on the network, allow the nodal watertable elevations to be determined.

ii) The future assumed percolation and abstraction data in each nodal area must be prescribed for each production run. First the percolation and/or abstraction rates as they will be under the development plan are calculated. These rates are then superimposed on the present rates, which may consist of percolation from rainfall, groundwater inflow and/or outflow over the boundaries of the area, abstraction from wells, etc. The final rates must be prescribed for each month and for the number of years one wants to simulate. Depending on conditions, there are two ways in which one can proceed.

Firstly, it is sometimes justified to assume that the percolation and abstraction rates will not vary substantially from year to year, although they may vary from month to month within each year. In such circumstances one can prepare monthly nodal percolation and abstraction rates for *one* year, based on an average of the future percolation and abstraction rates. Using the external switch LSW4 in Data Set II (see Chap. 4 Sect. 2.2) one can repeat this one-year data base for the number of years one wants to simulate. This saves considerable time in data preparation. The results of such a run will show how long it will take before a "new" steady-state condition in the groundwater basin is reached and to what extent the watertable will rise or fall.

Unfortunately, situations as simple as that described above will not often be encountered and it will be far more common to meet situations in which percolation from rainfall plays an important role, with rainfall varying strongly from one year to another, or in which abstraction rates from pumped wells are expected to vary due to a non-regulated surface water supply. Here, one cannot base production runs on average conditions, but must prepare monthly percolation and abstraction rates for *each* separate year. Because production runs are projections of possible future conditions, one must use probability analysis to quantify the variations of the different percolation and/or abstraction rates from one year to another and

derive stochastic sequences. Figure 6.9 shows an example of stochastically determined abstraction rates, in which years of "normal" stream flow are followed by dry years when groundwater is mined to meet the water demand.

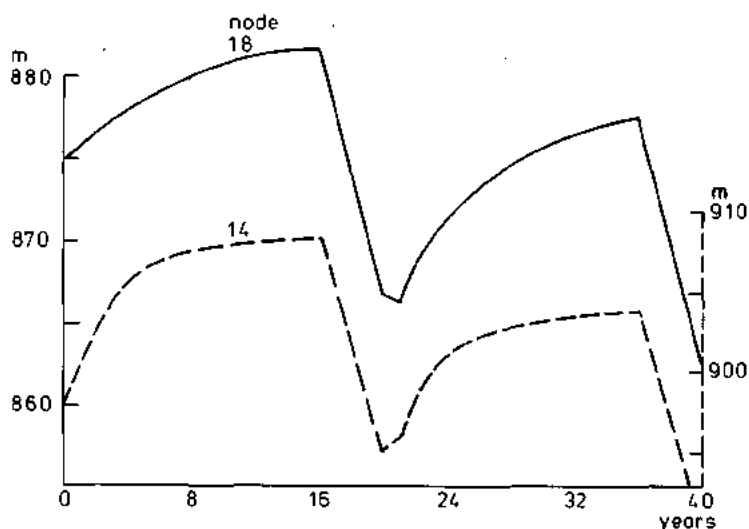

Fig. 6.9 Watertable behaviour of two nodes for stochastically varying abstraction rates (de Ridder and Erez 1977)

For more information on this subject, the reader is referred to ILRI Publication 21: *Optimum use of water resources* (de Ridder and Erez 1977).

iii) The introduction of surface water irrigation or groundwater abstraction may cause a change in the boundary conditions of the study area. These future boundary conditions must be prescribed. Zero-flow boundaries constitute no problem because they remain unchanged. Flow-controlled and head-controlled boundaries, however, require a projection of how they may change under future conditions. A way to avoid this problem is to extend the network over such a large area that no matter what the future conditions are, they will not exert any influence on the boundaries of the aquifer. If such an extension is impossible, one must analyse the behaviour of the boundary conditions in the past and extrapolate this into the future.

6.2.3 Sensitivity analysis

A sensitivity analysis made during production runs can analyse the sensitivity of an aquifer to changes in the hydrological stress exerted on it. Two separate occasions call for a sensitivity analysis.

Firstly, a new development plan implies a whole set of assumptions: a new cropping pattern, a new water delivery system, improved irrigation efficiencies, groundwater pumped by individual farmers or supplied from wells owned by the state, and so on. All these assumptions and corresponding data are drawn up from behind a desk; they are design values. In reality, when the plan is implemented, there will be many deviations: some farmers will not pump groundwater or will pump it for shorter or longer periods than were envisaged; irrigation conveyance, distribution, and field application efficiencies will differ from the assumed ones, and so on. Making a sensitivity analysis of the major assumptions will show how sensitive the different parts of the aquifer are to deviations from the design values. If such a sensitivity analysis shows that certain of the assumptions are highly sensitive i.e. that deviations in them will result in appreciably different watertable behaviour, one must make a number of alternative runs, showing the influence of these deviations on the watertable. The decision-maker will then be forewarned and can perhaps re-evaluate the assumptions.

Secondly, once certain values have been assigned to the head- and flow-controlled boundaries, these boundary conditions will influence the future watertable behaviour. If the network does not extend far enough beyond the area that will be affected by major changes in the hydrological stress, the future conditions at the boundaries can differ appreciably from the present ones. A sensitivity analysis of the boundary conditions, performed by making production runs with varying watertable elevations and/or flows across the boundaries, will show the influence of such variations on future watertable behaviour. If an appreciable influence is found, one must enlarge the area simulated.

6.2.4 Network modification

When a series of production runs have been made to test various alternative plans, their results should be examined and non-feasible plans should be discarded. After ranking the remaining plans, it may happen that one wants to make a more accurate study of one or two of the "best" alternatives. To do so, one may need a different, denser, nodal network than that used in the earlier runs. This will be so, for instance, when one needs more accurate values of watertable elevations in areas where future abstraction rates will be high and where, consequently, hydraulic gradients will be steep. The mesh size of the network in such areas should then be reduced accordingly.

The data on the geometry of the new network must be prepared and the data on its hydrogeological parameters derived by interpolation from the ones found after calibration.

APPENDIX 1

LISTING OF SOURCE PROGRAMS

Source programs listings are given to illustrate where to make any changes demanded by the user's nodal network or his computer system.

Copies of the source programs in the form of a complete set of punched cards can be ordered from ILRI; the only costs involved are those of copying the programs and of mailing the cards. All dimension statements in these copies refer to a network of 71 nodal areas and 39 boundary conditions.

```

C   GROUNDWATERMODEL/PART1 : READING INPUT DATA(POLYGONS/INHOMOGENOUS)
    INTEGER TNN
    REAL LENGTH
    DIMENSION PERM(7),NS(7),TITLE(40),TMBAS(2)
    DIMENSION ASC( NN),UL( NN),OL( NN),AREA( NN),AS( NN),SL( NN)
    DIMENSION BL(TNN),NSIDE( NN),PCONF( NN),NREL( NN,7),CONDU( NN,7)
    DIMENSION CO(TNN,2)
    IRD=8
    IPR=5
    IOSK1=1
40  READ(IRD,40) TITLE
    FORMAT(20A4/20A4)
    READ(IRD,1) NN,NSCONF,NCONF,NEXTN
1   FORMAT(4I4)
    TNN=NN+NEXTN
    NO=NN+1
    NCONF=NCONF+NCONF
    NPH=NN+NCONF
    NNC=NCONF+NCONF
    DO 47 I=1,NN
    DO 47 J=1,7
47  NREL(I,J)=0
    CONDU(I,J)=0.0
10  READ(IRD,10) (NSIDE(K),K=1,NN)
    FORMAT(40I2)
42  READ(IRD,42) ((CO(I,J),J=1,2),I=1,TNN)
    FORMAT(16F5,2)
46  READ(IRD,46) TMBAS,OMTIM,T,SCALE,LSW1
    FORMAT(2A4,2F4.1,F8.0,I4)
3   READ (IRD,3) DELTA,MINOR,MAJOR,LIST
    FORMAT (F4.2,3I4)
4   READ (IRD,4)ERROR,COEFFA
    FORMAT (2F8.2)
44  WRITE(IPR,44) TITLE
12  WRITE(IPR,12) NN,NEXTN,NCONF,NNC,NPH
    FORMAT(28H NUMBER OF INTERNAL NODES IS,I4/28H NUMBER OF EXTERNAL N
    ODES IS,I4//38H NUMBER OF SEMICONFINED NODAL AREAS IS,I4/38H NUMB
    2ER OF CONFINED NODAL AREAS IS,I4/38H NUMBER OF UNCONFINED NODA
    3L AREAS IS,I4/)
    IF(LSW1.EQ.1) WRITE(IPR,17)
    IF(LSW1.EQ.2) WRITE(IPR,39)
17  FORMAT(//30H UNIT LENGTH : 1 METRE/34H UNIT AREA : 1,000
    1,000 SQ.METRES/34H UNIT VOLUME : 1,000,000 CU.METRES)
39  FORMAT(//22H UNIT LENGTH : 1 METRE/25H UNIT AREA : 1 SQ.METRE/25
    1H UNIT VOLUME : 1 CU.METRE)
45  WRITE(IPR,45) TMBAS
    FORMAT(//50H UNIT OF TIME FOR DELTA AND BOUNDARY CONDITIONS IS,2A4
    1)
    WRITE(IPR,13)
13  FORMAT(//13H BETWEEN NODE,4X,12HPERMEABILITY,4X,5HWIDTH,4X,6HLENGT
    1H,18X,8HNODE NO.,,10X,8HX=COORD.,,10X,8HY=COORD.,,10X,6HBOTTOM/18X,10
    2HSG,M-DAY/M,6X,2HCM,8X,2HCM,41X,2HCM,15X,2HCM,13X,9HELEVATION//)
    READ(IRD,6)(BL(K),K = 1,TNN)
    TAREA=0.
    DO 11 I=1,NN
    J2=NSIDE(I)
15  READ (IRD,15) K,(NS(J),PERM(J),J=1,J2)
    FORMAT(13,7X,7(13,F5.2,2X))
    DO 41 J=1,J2.

```



```

NREL(K,J)=NS(J)
41 CONDU(K,J)=PERM(J)
11 CONTINUE
DO 49 K=1,NN
J2=NSIDE(K)
DO 52 J=1,J2
NOD=NREL(K,J)
IF(NOD,LT,K,OR,NOD,GT,NN) GO TO 52
J3=NSIDE(NOD)
DO 54 J1=1,J3
IF(NREL(NOD,J1),NE,K) GO TO 54
GO TO 55
54 CONTINUE
55 IF(CONDU(K,J),EQ,CONDU(NOD,J1)) GO TO 52
WRITE(IPR,53) K,NOD,NOD,K
53 FORMAT(30H PERMEABILITIES BETWEEN NODES ,I3,1H/,I3,5H AND ,I3,1H/,
1I3,17H ARE NOT THE SAME)
52 CONTINUE
49 CONTINUE
JJ=0
DO 10 K=1,NN
J2=NSIDE(K)
DUM=0.0
DO 35 J=1,J2
JJ=JJ+1
NS(I)=NREL(K,J)
IF(J=1,EQ,0) NS(2)=NREL(K,J2)
IF(J=1,NE,0) NS(2)=NREL(K,J+1)
IF(J,EQ,J2) NS(3)=NREL(K,1)
IF(J,NE,J2) NS(3)=NREL(K,J+1)
DO 36 I=1,3
X=CO(K,1)=CO(NS(I),1)
Y=CO(K,2)=CO(NS(I),2)
36 PERM(I)=X*X+Y*Y
DO 37 I=2,3
X=CO(NS(I),1)=CO(NS(I),1)
Y=CO(NS(I),2)=CO(NS(I),2)
37 PERM(I+2)=X*X+Y*Y
B2=PERM(2)*PERM(4)=PERM(1)
IF(B2,LT,0.0) WRITE(IPR,40) K,NS(2),NS(1)
B2=PERM(3)*PERM(5)=PERM(1)
IF(B2,LT,0.0) WRITE(IPR,40) K,NS(3),NS(1)
40 FORMAT(/30H THE ANGLE FORMED BY THE NODES,I3,2H ,,I3,2H ,,I3,27H I
;S GREATER THAN 90 DEGREES/)
A=PERM(1)
B=(PERM(4)+PERM(2)+PERM(1))*2.
C=(PERM(3)+PERM(5)+PERM(1))*2.
D=4*PERM(4)*PERM(2)
E=4*PERM(3)*PERM(5)
WIDTH=SQRT((0.25*A+B)/(D-B))+SQRT((0.25*A+C)/(E-C))
LENGTH=SQRT(A)
IF(JJ,GT,TNN) WRITE(IPR,16) K,NS(1),CONDU(K,J),WIDTH,LENGTH
IF(JJ,LE,TNN) WRITE(IPR,16) K,NS(1),CONDU(K,J),WIDTH,LENGTH,JJ,CO(
1JJ,1),CO(JJ,2),BL(JJ)
16 FORMAT(I5,4H AND,I4,10X,F5,2,5X,F5,2,5X,F5,2,10X,I5,15X,F5,2,13X,F
15,2,F16,0)
IF(LSW1,EQ,1) CONDU(K,J)=(CONDU(K,J)*(WIDTH/LENGTH)*DMTIM)/1000000.
IF(LSW1,EQ,2) CONDU(K,J)=CONDU(K,J)*(WIDTH/LENGTH)*DMTIM
DUM=DUM+WIDTH*LENGTH
35 CONTINUE

```

```

IF(LSW1, EQ, 1) AREA(K) = DUM * 0.25 * (SCALE / 100000.) ** 2.
IF(LSW1, EQ, 2) AREA(K) = DUM * 0.25 * (SCALE / 100.) ** 2.
18 TAREA = TAREA + AREA(K)
   READ(IRD, 43) (CO(I, 1), I = 1, NN)
43  FORMAT(11F7.5)
   IF(NSCONF, GT, 0) READ(IRD, 5) (PCONF(K), K = 1, NSCONF)
5   FORMAT(10F8.4)
   IF(NSCONF, GT, 0) READ(IRD, 43) (ASC(I), I = 1, NSCONF)
   DO 38 K = 1, NN
38  AS(K) = AREA(K) * CO(K, 1)
   READ(IRD, 6) (SL(K), K = 1, NN)
   IF(NCONF, NE, 0) READ(IRD, 6) (CO(I, 2), I = 1, NCONF)
6   FORMAT(20F4.0)
   READ(IRD, 2) LSW2, DELO
2   FORMAT(14, F4.1)
   IF(LSW2, EQ, 2) GO TO 7
   READ(IRD, 5) (UL(K), K = 1, NN)
   READ(IRD, 5) (OL(K), K = 1, NN)
   GO TO 9
7   DO 8 K = 1, NN
   UL(K) = SL(K)
8   OL(K) = BL(K)
9   WRITE (IPR, 19)
19  FORMAT(/ / 5H NODE, 5X, 4H AREA, 5X, 14H STORAGE COEFF., 6X, 7H SURFACE, 8X, 9H
1THICKNESS, 7X, 9H THICKNESS, 5X, 12H PERMEABILITY, 5X, 14H STORAGE COEFF., 7
22X, 7H AQUIFER, 9X, 9H ELEVATION, 5X, 12H CONF. AQUIFER, 6X, 8H TOPLAYER, 7X, 8H
3TOPLAYER, 10X, 8H TOPLAYER /)
   DUM = 0.0
   DO 50 K = 1, NN
   DL = BL(K) * CO(K, 2)
   IF(K, LE, NSCONF) WRITE (IPR, 20) K, AREA(K), CO(K, 1), SL(K), CO(K, 2), DL, P
1CONF(K), ASC(K)
   IF(K, GT, NSCONF, AND, K, LE, NCONF) WRITE (IPR, 20) K, AREA(K), CO(K, 1), SL
1(K), CO(K, 2)
   IF(K, GT, NCONF) WRITE (IPR, 20) K, AREA(K), CO(K, 1), SL(K)
20  FORMAT(13, F11.2, F14.5, F17.8, F15.0, F16.0, F16.3, F18.3)
50  CONTINUE
   WRITE (IPR, 33) TAREA
33  FORMAT(/ F14.2)
   IF(NSCONF, EQ, 0.) GO TO 34
   DO 51 K = 1, NSCONF
   PCONF(K) = PCONF(K) * DHTIM
51  ASC(K) = AREA(K) * ASC(K)
34  IF(LSW2, EQ, 2) GO TO 23
   WRITE (IPR, 21)
21  FORMAT(/ / 5H NODE, 5X, 12H UPPER LIMITS, 5X, 12H LOWER LIMITS / /)
   WRITE (IPR, 22) (K, UL(K), OL(K), K = 1, NN)
22  FORMAT(13, F16.2, F17.2)
23  WRITE (IPR, 24)
24  FORMAT(/ / 4X, 23H MISCELLANEOUS CONSTANTS, 10X, 27H VALUES OF EXTERNAL S
1WITCHES /)
   WRITE (IPR, 25) LIST, LSW1
25  FORMAT(6X, 7H LIST = , 17, 26X, 7H LSW1 = , 12)
   WRITE (IPR, 31) MAJOR, LSW2
31  FORMAT(5X, 8H MAJOR = , 17, 26X, 7H LSW2 = , 12)
   WRITE (IPR, 32) MINOR
32  FORMAT(5X, 8H MINOR = , 17)
   WRITE (IPR, 27) SCALE
27  FORMAT(5X, 8H SCALE = , F10.2)
   WRITE (IPR, 28) COEFFA

```

```

28  FORMAT(4X,9HCDEFFA = ,F10,2)
    WRITE(IPR,14) DNTIM
14  FORMAT(5X,8HDHTIM = ,F10,2)
    WRITE (IPR,26)DELTA
26  FORMAT(5X,8HDELTA = ,F14,6)
    WRITE (IPR,29)ERROR
29  FORMAT(5X,8HERROR = ,F14,6)
    WRITE(IPR,30)DELO
30  FORMAT(6X,7HDELU = ,F14,6)
    WRITE(IDSK1) DELO,COEFFA,T,HN,NO,TNN,ERROR,DELTA,NCONF,LSW1
    WRITE(IDSK1) TITLE,TMBAS,(BL(K),K=1,TNN),LIST,MAJOR,MINOR,NSCONF
    WRITE(IDSK1) (UL(K),DL(K),SL(K),AREA(K),AS(K),NSIDE(K),K=1,NN)
    WRITE(IDSK1) ((NREL(K,J),CO:DU(K,J),J=1,7),K=1,NN)
    IF(NCONF.GT.0) WRITE(IDSK1) (CO(I,2),I=1,NCONF)
    IF(NSCONF.GT.0) WRITE(IDSK1) (ASC(K),PCONF(K),K=1,NSCONF)
END

```

```

C GROUNDWATERMODEL/PART2 : CALCULATION OF GROUNDWATER FLOW(GAUSS/SEIDEL)
  INTEGER TNN,SUBITR
  REAL IMP
  DIMENSION NREL( NN,7),NSIDE( NN),AREA( NN),TITLE(40),TMBAS(2)
  DIMENSION H(TNN),HO( NN),HT( NN),HCONF( NN),HOCONF( NN),DRECH( NN)
  DIMENSION RECH( NN),FLWCON( NN),TOTALQ( NN),S( NN),QSEEP( NN)
  DIMENSION CONDU( NN,7),PCONF( NN),SC( NN),ASC( NN),AS( NN)
  DIMENSION BL(TNN),UL( NN),OL( NN),THID( NN),SL( NN)

C
  IRD=0
  IPR=5
  IDSK1=1
  IDSK2=2
  REWIND IDSK1
  READ(IDSK1) DELQ,COEFFA,T,NN,HO,TNN,ERROR,DELTA,NCONF,LSW1
  READ(IDSK1) TITLE,TMBAS,(BL(K),K=1,TNN),LIST,MAJOR,MINOR,NSCONF
  READ(IDSK1) (UL(K),OL(K),SL(K),AREA(K),AS(K),NSIDE(K),K=1,NN)
  READ(IDSK1) ((NREL(K,J),CONDU(K,J),J=1,7),K=1,NN)
  IF(HCONF.GT.0) READ(IDSK1) (THID(I),I=1,NCONF)
  IF(NSCONF.GT.0) READ(IDSK1) (ASC(K),PCONF(K),K=1,NSCONF)
  READ(IRD,38) LSW3,LSW4,LSW5,LSW6
38  FORMAT(4I4)
  READ (IRD,18) (H(K),K=1,TNN)
  IF(NSCONF.GT.0) READ(IRD,18) (HCONF(K),K=1,NSCONF)
18  FORMAT(10F8,2)
  WRITE(IDSK2) LIST,MAJOR,MINOR,DELTA,T,NN,TNN,LSW1
  WRITE(IDSK2) (H(K),K=1,TNN),NSCONF,(SL(K),K=1,NN),NCONF,TITLE,TMBAS
  IF(NSCONF.GT.0) WRITE(IDSK2) (HCONF(K),K=1,NSCONF)
  WRITE(IPR,40)
40  FORMAT(12H CALCULATION////)
  WRITE(IPR,39) TITLE
39  FORMAT(21H GROUNDWATERMODEL FOR,20A4/20A4)
  WRITE(IPR,41)
41  FORMAT(///28H VALUES OF EXTERNAL SWITCHES/)
  WRITE(IPR,42) LSW3,LSW4,LSW5,LSW6
42  FORMAT(10X,7HLSW3 = ,I2/10X,7HLSW4 = ,I2/10X,7HLSW5 = ,I2/10X,7HLS
1W6 = ,I2)
  DO 90 L=1,LIST
  IF(LSW3.NE.1) GO TO 31
  READ(IRD,1) (RECH(K),K=1,NN)
1  FORMAT(8X,14F5,3)
  READ(IRD,2) (FLWCON(K),K=1,NN)
2  FORMAT(8X,7F10,4)
  DO 32 K=1,NN
32  RECH(K)=RECH(K)+AREA(K)
  READ(IRD,4) (H(K),K=NO,TNN)
4  FORMAT(8X,9F8,2)
31  DO 80 M=1,MAJOR
  IF(LSW4.EQ.1.AND.L.NE.1) GO TO 5
  IF(LSW3.NE.2) GO TO 5
  READ(IRD,1) (RECH(K),K=1,NN)
  READ(IRD,2) (FLWCON(K),K=1,NN)
  DO 3 K=1,NN
3  RECH(K)=RECH(K)+AREA(K)
  READ(IRD,4) (H(K),K=NO,TNN)
5  DO 70 JT = 1,MINOR
  IF(LSW3.NE.3) GO TO 7
  READ(IRD,1) (RECH(K),K=1,NN)
  READ(IRD,2) (FLWCON(K),K=1,NN)
  DO 6 K=1,NN

```

```

6 RECH(K)=RECH(K)+AREA(K)
  READ(IRD,4) (H(K),K=NO,TNN)
7 IF(LSW5,EQ,2) READ(IRD,20) DELTA
28 FORMAT(F6,4)
  T = T + DELTA
  ITRNO = 0
  DO 6 K=1,NN
    DRECH(K)=0,0
8 HO(K) = H(K)
  DO 35 K=1,NSCONF
    QSEEP(K)=0,0
    SC(K)=0,0
35 HOCONF(K)=HCONF(K)
9 ITRNO = ITRNO + 1
  SUBITR=0
10 LM=0
  ITOET=1
  SUM=0,0
  DO 14 K=1,NN
    RES=0,0
    IMP=0,0
    HL=H(K)
    J2=NSIDE(K)
    DO 13 J=1,J2
      NOD=NREL(K,J)
      B=(BL(NOD)+BL(K))/2,
      HA=(H(NOD)+HL)/2,
      THI=HA-B
      IF(K,LE,NSCONF,AND,NOD,LE,NSCONF) THI=(THID(K)+THID(NOD))*0,5
      IF(K,LE,NSCONF) THI=THID(K)
      IF(NOD,LE,NSCONF) THI=THID(NOD)
      Y=THI*CONDU(K,J)
      IMP=IMP+Y
      U=Y*(H(NOD)-HL)
      RES=RES+U
13 CONTINUE
    TOTALQ(K)=RES
    S(K)=(HO(K)-HL)*AS(K)/DELTA
    IF(K,GT,NSCONF) GO TO 33
    DL=BL(K)+THID(K)
    IF(HCONF(K),LE,DL) GOTO 30
    C=(HCONF(K)-DL)/PCONF(K)
    QSEEP(K)=((HCONF(K)-HL)/C)*AREA(K)
    IF(HL,LE,DL) QSEEP(K)=((HCONF(K)-DL)/C)*AREA(K)
    GOTO 43
30 QSEEP(K)=0,0
43 RES=RES+FLWCON(K)+QSEEP(K)+S(K)+DRECH(K)
  SC(K)=(HOCONF(K)-HCONF(K))*ASC(K)/DELTA
  RESC=RECH(K)+SC(K)+QSEEP(K)
  IF(LSW6,EQ,1) HCONF(K)=HCONF(K)+RESC/(ASC(K)/DELTA+AREA(K)/C)
  H(K)=HL+(RES*COEFFA/(IMP+AS(K)/DELTA+AREA(K)/C))
  GO TO 34
33 IF(K,LE,NSCONF) RECH(K)=0,0
  RES=RES+RECH(K)+S(K)+FLWCON(K)+DRECH(K)
  H(K)=HL+(RES*COEFFA/(IMP+AS(K)/DELTA))
34 SUM=SUM+ABS(RES)
14 CONTINUE
  IF(SUM,GT,ERROR) ITOET=2
  IF(SUBITR,LT,49) GO TO 17
  WRITE(IPR,16) T

```

```

16  FORMAT(/26H DELQ IS TOO SMALL AT TIME,F8,4/)
17  IF(ITRNO.LT.50) GO TO 20
    WRITE(IPR,19) T
19  FORMAT(/60X,37H RELAXATION FAILS TO CONVERGE AT TIME,F8,4)
20  DO 25 K = 1,NN
    IF(H(K).GE.OL(K).AND.H(K).LT.UL(K)) GO TO 25
    IF(ABS(FLWCON(K)).GT.ABS(RECH(K))) GO TO 21
    TORECH=ABS(RECH(K))*DELO
    GO TO 22
21  TORECH=ABS(FLWCON(K))*DELO
22  IF(H(K).LT.OL(K)) GO TO 23
    IF(K.LE.NCONF) GO TO 25
    DRECH(K)=DRECH(K)-TORECH
    GO TO 24
23  DRECH(K)=DRECH(K)+TORECH
24  LM = 1
25  CONTINUE
    IF(ITRNO.GE.50.OR.SUBITR.GE.50) GO TO 37
    IF(LM.EQ.1) SUBITR=SUBITR+1
    IF(LM.EQ.1) GO TO 10
    IF(ITDET.EQ.2) GO TO 9
37  DO 26 K=1,NN
    IF(K.GT.NSCONF) GO TO 27
    IF(HCONF(K).GT.SL(K)) WRITE(IPR,29) K,T
29  FORMAT(/39H WATER TABLE IN CONFINING LAYER AT NODE,13,31H IS ABOVE
    1E SURFACE LEVEL AT TIME,F8,4)
27  IF(K.GT.NCONF) GO TO 26
    IF(H(K).LT.(BL(K)+THID(K))) WRITE(IPR,36) K,T
36  FORMAT(/37H PIEZOMETRIC LEVEL IN AQUIFER AT NODE,13,26H IS BELOW
    1TOPLAYER AT TIME,F8,4)
26  CONTINUE
    WRITE(IDSK2) (RECH(K),TOTALQ(K),S(K),FLWCON(K),DRECH(K),K=1,NN)
    WRITE(IDSK2) (H(K),K=1,TNN),T,ITRNO,DELTA,SUBITR
    IF(NSCONF.GT.0) WRITE(IDSK2) (HCONF(K),QSEEP(K),SC(K),K=1,NSCONF)
70  CONTINUE
80  CONTINUE
90  CONTINUE
    END

```

```

C GROUNDWATERMODEL/PART3A : PRINTING OF RESULTS
  INTEGER TNN,SUBITR
  DIMENSION H(TNN),SL(NN),HCONF(NN),TITLE(40),TMBAS(2)
  DIMENSION RECH(NN),FLWCON(NN),TOTALQ(NN),S(NN),QSEEP(NN)
  DIMENSION SC(NN),DRECH(NN),TOTRE(NN),TOTFC(NN),TOTSQ(NN)
  DIMENSION TOTS(NN),TOTQS(NN),TOTSC(NN),TOTDQ(NN)
  IRD=8
  IPR=5
  IDSK2=2
  REWIND IDSK2
  READ(IDSK2) LIST,MAJOR,MINOR,DELTA,T,NN,TNN,LSW1
  READ(IDSK2) (H(K),K=1,TNN),NSCONF,(SL(K),K=1,NN),NCONF,TITLE,TMBAS
  IF(NSCONF.GT.0) READ(IDSK2) (HCONF(K),K=1,NSCONF)
14 READ(IRD,14) LSW7,LSW8,LSW9
  FORMAT(3I4)
  IF(LSW9.EQ.1) NT=NN
  IF(LSW9.EQ.2) NT=TNN
  NEXTN=TNN-NN
  NPH=NN-NCONF
  NNC=NCONF-NSCONF
  WRITE(IPR,1)
  1 FORMAT(9H SOLUTION////)
  WRITE(IPR,44) TITLE
  44 FORMAT(21H GROUNDWATERMODEL FOR,20A4/20A4//)
  WRITE(IPR,43) NN,NEXTN,NSCONF,NNC,NPH
  43 FORMAT(28H NUMBER OF INTERNAL NODES IS,14/28H NUMBER OF EXTERNAL N
  10DES IS,14//38H NUMBER OF SEMICONFINED NODAL AREAS IS,14/38H NUMB
  2ER OF CONFINED NODAL AREAS IS,14/38H NUMBER OF UNCONFINED NODA
  3L AREAS IS,14//)
  IF(LSW1.EQ.1) WRITE(IPR,42)
  IF(LSW1.EQ.2) WRITE(IPR,39)
  42 FORMAT(/30H UNIT LENGTH : 1 METRE/34H UNIT AREA : 1,000
  1,000 SQ,METRES/34H UNIT VOLUME : 1,000,000 CU,METRES)
  39 FORMAT(/22H UNIT LENGTH : 1 METRE/25H UNIT AREA : 1 SQ,METRE/25
  1H UNIT VOLUME : 1 CU,METRE)
  WRITE(IPR,47) TMBAS
  47 FORMAT(/50H UNIT OF TIME FOR DELTA AND BOUNDARY CONDITIONS IS,2A4
  1)
  WRITE(IPR,27)
  27 FORMAT(/28H VALUES OF EXTERNAL SWITCHES/)
  WRITE(IPR,28) LSW7,LSW8,LSW9
  28 FORMAT(10X,7HLSW7 = ,I2/10X,7HLSW8 = ,I2/10X,7HLSW9 = ,I2)
  WRITE(IPR,2)
  2 FORMAT(///31H INITIAL WATER LEVEL ELEVATIONS/)
  WRITE(IPR,3) T
  3 FORMAT(/9H T = ,F10.4//)
  DO 4 K=1,NT
  IF(K.LE.NSCONF) WRITE(IPR,41) K,H(K),HCONF(K)
  IF(K.GT.NSCONF.AND.K.LE.NCONF) WRITE(IPR,40) K,H(K)
  IF(K.GT.NCONF) WRITE(IPR,45) K,H(K)
  41 FORMAT(9H NODE NO.,14,5X,17HHZERO SEMICNF = ,F8.4,5X,5HH1 = ,F8.4
  1)
  40 FORMAT(9H NODE NO.,14,5X,17HHZERO CONFINED = ,F8.4)
  45 FORMAT(9H NODE NO.,14,5X,17HHZERO UNCONF = ,F8.4)
  4 CONTINUE
  DO 90 L=1,LIST
  IF(LSW8.NE.3) GO TO 6
  DO 5 K=1,NN
  TOTRE(K)=0.0
  TOTSQ(K)=0.0
  TOTS(K)=0.0

```

```

TOTFC(K)=0.0
TOTDQ(K)=0.0
IF(K.GT.NSCONF) GO TO 5
TOTSC(K)=0.0
TOTQS(K)=0.0
5 CONTINUE
TYRE=0.0
TTSQ=0.0
TYS=0.0
TTSC=0.0
TTFC=0.0
TTQS=0.0
TTDQ=0.0
6 DO 80 H=1,MAJOR
IF(LSW0.NE.2) GO TO 8
DO 7 K=1,NN
TOTRE(K)=0.0
TOTSQ(K)=0.0
TOTS(K)=0.0
TOTFC(K)=0.0
TOTDQ(K)=0.0
IF(K.GT.NSCONF) GO TO 7
TOTSC(K)=0.0
TOTQS(K)=0.0
7 CONTINUE
TYRE=0.0
TTSQ=0.0
TYS=0.0
TTSC=0.0
TTFC=0.0
TTQS=0.0
TTDQ=0.0
8 DO 70 JT=1,MINOR
IF(LSW0.NE.1) GO TO 10
DO 9 K=1,NN
TOTRE(K)=0.0
TOTSQ(K)=0.0
TOTS(K)=0.0
TOTFC(K)=0.0
TOTDQ(K)=0.0
IF(K.GT.NSCONF) GO TO 9
TOTSC(K)=0.0
TOTQS(K)=0.0
9 CONTINUE
TYRE=0.0
TTSQ=0.0
TYS=0.0
TTSC=0.0
TTFC=0.0
TTQS=0.0
TTDQ=0.0
10 READ(IDSK2) (RECH(K),TOTALQ(K),S(K),FLWCON(K),DRECH(K),K=1,NN)
READ(IDSK2) (H(K),K=1,TNN),T,ITRNO,DELTA,SUBITR
IF(NSCONF.GT.0) READ(IDSK2) (HCONF(K),QSEEP(K),SC(K),K=1,NSCONF)
DO 11 K=1,NN
TOTRE(K)=TOTRE(K)+RECH(K)+DELTA
TOTSQ(K)=TOTSQ(K)+TOTALQ(K)+DELTA
TOTS(K)=TOTS(K)+S(K)+DELTA
TOTFC(K)=TOTFC(K)+FLWCON(K)+DELTA
TOTDQ(K)=TOTDQ(K)+DRECH(K)+DELTA

```



```

IF(K,GT,NSCONF) GO TO 11
TOTSC(K)=TOTSC(K)+SC(K)*DELTA
TOTQS(K)=TOTQS(K)+QSEEP(K)*DELTA
11 CONTINUE
DO 12 K=1,NN
TTRE=TTRE+RECH(K)*DELTA
TTSQ=TTSQ+TOTALQ(K)*DELTA
TTS=TTS+S(K)*DELTA
TTFC=TTFC+FLWCON(K)*DELTA
TTDQ=TTDQ+DRECH(K)*DELTA
IF(K,GT,NSCONF) GO TO 12
TTSC=TTSC+SC(K)*DELTA
TTQS=TTQS+QSEEP(K)*DELTA
12 CONTINUE
WRITE (IPR,13) T,ITRNO,SUBITR
13 FORMAT(////5H T = ,F10.4,8X,20HNO. OF ITERATIONS = ,I3,8X,23HNO.
10F SUBITERATIONS = ,I3/)
IF(LSW7,NE,1) GO TO 15
DO 38 K=1,NT
IF(K,LE,NSCONF) WRITE(IPR,37) K,H(K),HCONF(K)
IF(K,GT,NSCONF,AND,K,LE,NCONF) WRITE(IPR,36) K,H(K)
IF(K,GT,NCONF) WRITE(IPR,35) K,H(K)
37 FORMAT(9H NODE NO.,I4,5X,13HH SEMICONF = ,F8.4,5X,5HH' = ,F8.4)
36 FORMAT(9H NODE NO.,I4,5X,13HH CONFINED = ,F8.4)
35 FORMAT(9H NODE NO.,I4,5X,13HH UNCONF = ,F8.4)
38 CONTINUE
15 IF(LSW8,NE,1) GO TO 70
WRITE(IPR,16)
16 FORMAT(//24H WATERBALANCE COMPONENTS)
WRITE(IPR,17)
17 FORMAT(//(5H NODE,4X,8HRECHARGE,4X,17HCHANGE IN STORAGE,4X,12HSEEP
1AGE FLOW,4X,17HCHANGE IN STORAGE,4X,21HTOTAL SUBSURFACE FLOW,4X,9H
2PUMP FLOW,4X,13HORAINAGE FLOW/24X,11HIN TOPLAYER,27X,10HIN AQUIFER
3/30X,53H(ALL COMPONENTS ARE CALCULATED FOR THE LAST TIMESTEP)/))
DUM=0.0
DO 18 K=1,NN
IF(K,LE,NSCONF) WRITE(IPR,19) K,TOTRE(K),TOTSC(K),TOTQS(K),TOTS(K)
1,TOTSQ(K),TOTFC(K),TOTDQ(K)
IF(K,GT,NSCONF,AND,K,LE,NCONF) WRITE(IPR,19) K,DUM,DUM,DUM,TOTS(K)
1,TOTSQ(K),TOTFC(K),TOTDQ(K)
IF(K,GT,NCONF) WRITE(IPR,19) K,TOTRE(K),DUM,DUM,TOTS(K),T
1TOTFC(K),TOTDQ(K)
19 FORMAT(I5,F12.4,F21.4,F16.4,F21.4,F25.4,F13.4,F17.4)
18 CONTINUE
WRITE(IPR,20)
20 FORMAT(//40H WATERBALANCE COMPONENTS FOR WHOLE BASIN/)
WRITE(IPR,21) TTRE,TTSC,TTQS,TTS,TTSQ,TTFC,TTDQ
21 FORMAT(F17.4,F21.4,F16.4,F21.4,F25.4,F13.4,F17.4)
70 CONTINUE
IF(LSW7,NE,2) GO TO 22
DO 34 K=1,NT
IF(K,LE,NSCONF) WRITE(IPR,37) K,H(K),HCONF(K)
IF(K,GT,NSCONF,AND,K,LE,NCONF) WRITE(IPR,36) K,H(K)
IF(K,GT,NCONF) WRITE(IPR,35) K,H(K)
34 CONTINUE
22 IF(LSW8,NE,2) GO TO 80
WRITE(IPR,16)
WRITE(IPR,23) MINOR
23 FORMAT(//(5H NODE,4X,8HRECHARGE,4X,17HCHANGE IN STORAGE,4X,12HSEEP
1AGE FLOW,4X,17HCHANGE IN STORAGE,4X,21HTOTAL SUBSURFACE FLOW,4X,9H

```

```

2PUMP FLOW,4X,13HDRAINAGE FLOW/24X,11HIN TOPLAYER,27X,10HIN AQUIFER
3/30X,43H(ALL COMPONENTS ARE CALCULATED FOR THE LAST,13,11H TIMESTE
4PS)/)
  DO 24 K=1,NN
    IF(K.LE.NSCONF) WRITE(IPR,19) K,TOTRE(K),TOTSC(K),TOTQS(K),TOTS(K)
1,TOTSQ(K),TOTFC(K),TOTDQ(K)
    IF(K.GT.NSCONF.AND.K.LE.NCONF) WRITE(IPR,19) K,DUM,DUM,DUM,TOTS(K)
1,TOTSQ(K),TOTFC(K),TOTDQ(K)
    IF(K.GT.NCONF) WRITE(IPR,19) K,TOTRE(K),DUM,DUM,TOTS(K),TOTSQ(K),T
1TOTFC(K),TOTDQ(K)
24  CONTINUE
    WRITE(IPR,20)
    WRITE(IPR,21) TTRE,TTSC,TTQS,TTT,TTSQ,TTFC,TTDQ
80  CONTINUE
    IF(LSN7,NE,3) GO TO 25
    DO 33 K=1,NT
      IF(K.LE.NSCONF) WRITE(IPR,37) K,H(K),HCONF(K)
      IF(K.GT.NSCONF.AND.K.LE.NCONF) WRITE(IPR,36) K,H(K)
      IF(K.GT.NCONF) WRITE(IPR,35) K,H(K)
33  CONTINUE
25  IF(LSN8,NE,3) GO TO 90
    WRITE(IPR,16)
    IYEAR=MAJOR*MINOR
    WRITE(IPR,23) IYEAR
    DO 26 K=1,NN
      IF(K.LE.NSCONF) WRITE(IPR,19) K,TOTRE(K),TOTSC(K),TOTQS(K),TOTS(K)
1,TOTSQ(K),TOTFC(K),TOTDQ(K)
      IF(K.GT.NSCONF.AND.K.LE.NCONF) WRITE(IPR,19) K,DUM,DUM,DUM,TOTS(K)
1,TOTSQ(K),TOTFC(K),TOTDQ(K)
      IF(K.GT.NCONF) WRITE(IPR,19) K,TOTRE(K),DUM,DUM,TOTS(K),TOTSQ(K),T
1TOTFC(K),TOTDQ(K)
26  CONTINUE
    WRITE(IPR,20)
    WRITE(IPR,21) TTRE,TTSC,TTQS,TTT,TTSQ,TTFC,TTDQ
90  CONTINUE
    END

```

```

C   GROUNDWATERMODEL/PART3B : PLOTTING OF RESULTS
      INTEGER TNN
      DIMENSION A(104),X(11),B(TNN,MAJOR),H(TNN,MAJOR),SL(NN),TI(100)
      DIMENSION TMBAS(2),TITLE(40)
      IRD=8
      IPR=5
      IDSK2=2
      REWIND IDSK2
      READ (IRD,1) BLNK,MI,HMINUS,HX,ASTRSK,HY,PLUS,LSW9,LSW10,LSW11
1     FORMAT (7A4,3I2)
      READ (IDSK2) LIST,MAJOR,MINOR,DUM,T,NN,TNN,IDUM
      READ (IDSK2) (H(K,1),K=1,TNN),NSCONF,(SL(K),K=1,NN),IDUM,TITLE,TMBAS
      IF (NSCONF.GT.0) READ (IDSK2)
      IF (LSW10.EQ.2) READ (IRD,14) MINOR,MAJOR,LIST
14    FORMAT (3I4)
      WRITE (IPR,33)
33    FORMAT (5H PLOT////)
      WRITE (IPR,29) TITLE
29    FORMAT (21H GROUNDWATERMODEL FOR,20A4/20A4)
      WRITE (IPR,31)
31    FORMAT (///28H VALUES OF EXTERNAL SWITCHES/)
      WRITE (IPR,32) LSW9,LSW10,LSW11
32    FORMAT (10X,8HLSW9 = ,I2/10X,8HLSW10 = ,I2/10X,8HLSW11 = ,I2)
      IF (LSW10.EQ.1) GO TO 35
      WRITE (IPR,34) MINOR,MAJOR,LIST
34    FORMAT (10X,8HMINOR = ,I4/10X,8HMAJOR = ,I4/10X,8HLIST = ,I4)
35    WRITE (IPR,30)
30    FORMAT (1H1)
      NO=NN+1
      IF (LSW9.EQ.1) NT=NN
      IF (LSW9.EQ.2) NT=TNN
      DO 90 L1=1,LIST
      DO 80 M=1,MAJOR
      DO 70 JT=1,MINOR
      READ (IDSK2)
      IF (JT.GE.MINOR) GO TO 70
      READ (IDSK2)
      IF (NSCONF.GT.0) READ (IDSK2)
70    CONTINUE
      READ (IDSK2) (B(K,M),K=1,TNN),TI(M)
      IF (NSCONF.GT.0) READ (IDSK2)
80    CONTINUE
      DO 3 M=1,MAJOR
      IF (LSW10.EQ.1) READ (IRD,2) (H(K,M),K=1,NN)
2     FORMAT (8X,9F8.2)
      DO 26 I=1,TNN
      IF (LSW10.EQ.1.AND,I.LE.NN) GO TO 26
      H(I,M)=B(I,M)
26    CONTINUE
3     CONTINUE
      DO 24 II=1,NT
      SMALL=B(II,1)
      HSMALL=H(II,1)
      BIG=B(II,1)
      HBIG=H(II,1)
      DO 4 J=1,MAJOR
      IF (B(II,J).LT,SMALL) SMALL=B(II,J)
      IF (H(II,J).LT,HSMALL) HSMALL=H(II,J)
      IF (SMALL.GT,HSMALL) SMALL=HSMALL
      IF (B(II,J).GT,BIG) BIG=B(II,J)

```

```

4     IF(H(II,J).GT,MBIG) MBIG=H(II,J)
      IF(BIG.LT,MBIG) BIG=MBIG
      SCALE=1,0
      IF(BIG-SMALL=1,0.GT, 8,0) GOTO 5
      GOTO 8
5     IF(BIG-SMALL=2,0.GT,16,0) GOTO 6
      SCALE=2,0
      GOTO 8
6     IF(BIG-SMALL=4,0.GT,32,0) GOTO 7
      SCALE=4,0
      GOTO 8
7     SCALE=8,0
8     IY=SMALL
      Y=IY
      XINC=1,0*SCALE
      DO 9 K=1,11
      X(K)=Y+XINC
9     XINC=XINC+SCALE
      IF(LSW10.EQ,1) WRITE(IPR,10) (X(K),K=1,11)
      IF(LSW10.EQ,2) WRITE(IPR,20) (X(K),K=1,11)
10    FORMAT(1H+,2X,11(F5,0,5X),17HCOMPT(+)) HIST(+))
28    FORMAT(1H+,2X,11(F5,0,5X),8HCOMPT(+))
      DO 11 I=1,10
      K=I+10-9
      A(K)=HI
      DO 11 J=1,9
      L=J+K
11    A(L)=HMINUS
      A(101)=HI
      DO 12 I=102,104
12    A(I)=BLNK
      WRITE(IPR,13) A
13    FORMAT(7X,104A1)
      DO 15 K=1,104
15    A(K)=BLNK
      XX=Y-SCALE
      DO 21 J=1,MAJOR
      ITT=TI(J)
      I=(B(II,J)-XX)/(SCALE/10,0)+1,5
      IH=(H(II,J)-XX)/(SCALE/10,0)+1,5
      VAL=B(II,J)
      HVAL=H(II,J)
      IF(LSW11.EQ,2) GO TO 36
      IF(II.GT,NN) GO TO 36
      B(II,J)=B(II,J)-H(II,J)
36    IF(IH.LE,0.OR,IH.GT,104) GOTO 20
      A(IH)=PLUS
16    IF(I.LE,0.OR,I.GT,104) GOTO 19
      A(I)=ASTRSK
17    IF(LSW10.EQ,1) WRITE(IPR,18) ITT,A,VAL,HVAL
      IF(LSW10.EQ,2) WRITE(IPR,18) ITT,A,VAL
18    FORMAT (16,1X,104A1,2(F9,2))
      A(I)=BLNK
      A(IN)=BLNK
      GO TO 21
19    I=102
      A(I)=HX
      GOTO 17
20    IH=104
      A(IH)=HY

```

```

GOTO 16
21 CONTINUE
   IF(II,LE,NN) WRITE (IPR,22) II,TMBAS,SL(II)
   IF(II,GT,NN) WRITE (IPR,27) II,TMBAS
22  FORMAT(/9H NODE NO,I4,13X,44H ELEVATIONS(METRES ABOVE SEALEVEL)
1VS, TIME(,2A4,1H),22H) SURFACE ELEVATION * ,F4,0)
27  FORMAT(/9H NODE NO,I4,26X,44H ELEVATIONS(METRES ABOVE SEALEVEL)
1VS, TIME(,2A4,1H))
   WRITE (IPR,23)
23  FORMAT(////)
24  CONTINUE
   IF(LSW11,EO,2) GO TO 90
   XI=0.0
   XI2=0.0
   DO 37 K=1,NN
   DO 38 J=1,MAJOR
   XI=XI+B(K,J)
38  XI2=XI2+B(K,J)*B(K,J)
37  CONTINUE
   MNN=MAJOR*NN
   OMEAN=XI/MNN
   OSDEV=SQRT((XI2*(XI+XI)/MNN)/(MNN-1))
   HT=MAJOR*LIST
   WRITE(IPR,41)
41  FORMAT(82HICALCULATION OF DEVIATIONS BETWEEN CALCULATED AND HISTOR-
1ICAL WATERTABLE ELEVATIONS//)
   WRITE(IPR,39) MAJOR,HT
39  FORMAT(87H THIS CALCULATION IS BASED ON THE DEVIATIONS OVER ALL TH
1E INTERNAL NODES AND TAKEN OVER,13,12H TIME STEPS,/63H TOTAL NUMBE
2R OF TIME STEPS IN THE ENTIRE CALCULATION PERIOD IS,13/)
   WRITE(IPR,40) OMEAN,OSDEV
40  FORMAT(22H MEAN * ,F5,2,6H METER/22H STANDARD DEVIAT
1ION * ,F5,2,6H METER)
   WRITE (IPR,25)
25  FORMAT(1H;)
90  CONTINUE
   END

```

```

C   GROUNDWATERMODEL/PART1 : READING INPUT DATA(SQUARE GRID/HOMOGENEOUS)
      INTEGER TNN
      REAL LENGTH
      DIMENSION PERH(7),NS(7),TITLE(40),TMBAS(2)
      DIMENSION ASC( NN),UL( NN),UL( NN),AREA( NN),AS( NN),SL( NN)
      DIMENSION BL(TNN),NSIDE( NN),PCONF( NN),NREL( NN,7),CONDU( NN,7)
      DIMENSION CO(TNN,2),RX(NX),RY(NY)
      IRD=8
      IPR=5
      IDSK1=1
      READ(IRD,40) TITLE
40    FORMAT(20A4/20A4)
      READ(IRD,1) NX,NY,NSCONF,NCONF,NEXTN
1     FORMAT(5I4)
      READ(IRD,2) SLC,BLC,STC,CONDC
2     FORMAT(2F4,0,F7,5,F8,4)
      READ(IRD,47) COTBY,COBBY,CORBX,COLBX,CONDTB,CONDOB,CONDRO,CONDLB
47    FORMAT(8F5,2)
      NN=NX*NY
      TNN=NN+NEXTN
      NO=NN+1
      NCONF=NCONF+NSCONF
      NPH=NN-NCONF
      NNC=NCONF-NSCONF
      N1=NY-2
      N3=NN+NX
      N4=NN+NX+1
      N5=NN+NX+NY
      READ(IRD,46) TMBAS,DMTIM,T,SCALE,LSW1
46    FORMAT(2A4,2F4,1,F8,0,I4)
      READ(IRD,3) DELTA,MINOR,MAJOR,LIST
3     FORMAT(F4,2,3I4)
      READ(IRD,4) ERNOR,COEFFA
4     FORMAT(2F8,2)
      READ(IRD,49) LSW2,DELO
49    FORMAT(I4,F4,1)
      DO 5 K=1,NN
      NSIDE(K)=4
5     SL(K)=SLC
      DO 9 K=1,TNN
      BL(K)=BLC
9     IF(LSW2,EQ,2) GO TO 7
      READ(IRD,48) ULC,OLC
48    FORMAT(2F4,0)
      DO 15 K=1,NN
      UL(K)=ULC
15    OL(K)=OLC
      GO TO 10
7     DO 8 K=1,NN
      UL(K)=SL(K)
8     OL(K)=BL(K)
10   WRITE(IPR,44) TITLE
44   FORMAT(21H GROUNDWATERMODEL FOR,20A4/20A4//)
      WRITE(IPR,12) NN,NEXTN,NSCONF,NNC,NPH
12   FORMAT(28H NUMBER OF INTERNAL NODES IS,I4/28H NUMBER OF EXTERNAL N
10DES IS,I4//38H NUMBER OF SEMICONFINED NODAL AREAS IS,I4/38H NUMB
2ER OF CONFINED NODAL AREAS IS,I4/38H NUMBER OF UNCONFINED NODA
3L AREAS IS,I4/)
      IF(LSW1,EQ,1) WRITE(IPR,17)
      IF(LSW1,EQ,2) WRITE(IPR,39)
17   FORMAT(/30H UNIT LENGTH :           1 METRE/34H UNIT AREA : 1,000

```

```

1,000 SQ. METRES/34H UNIT VOLUME : 1,000,000 CU. METRES)
39  FORMAT(/22H UNIT LENGTH : 1 METRE/25H UNIT AREA : 1 SQ. METRE/25
    1H UNIT VOLUME : 1 CU. METRE)
    WRITE(IPR,45) THBAS
45  FORMAT(/50H UNIT OF TIME FOR DELTA AND BOUNDARY CONDITIONS IS,2A4
    1)
    WRITE(IPR,13)
13  FORMAT(/13H BETWEEN NODE,4X,12H PERMEABILITY,4X,5H WIDTH,4X,6H LENGT
    1H,10X,8H NODE NO.,,10X,8HX=COORD.,10X,8HY=COORD./10X,10H SQ. M-DAY/M,6
    2X,2HCM,8X,2HCM,41X,2HCM,15X,2HCM//)
    TAREA=0.
    DO 11 I=1,NN
    J2=NSIDE(I)
    NS(1)=I+1
    NS(2)=I-NX
    NS(3)=I-1
    NS(4)=I+NX
    DO 41 J=1,J2
    NREL(I,J)=NS(J)
41  CONDU(I,J)=CONOUC
11  CONTINUE
    JJ=0
    DO 58 I=1,NX
    NREL(I,2)=I+NN
    CONDU(I,2)=CONDTB
58  CONDU(I+NN-NX,4)=CONDBB
    NREL(I+NN-NX,4)=I+TNN-NX
    IF(NY,LT,3) GOTO 63
    DO 59 I=1,NI
    NREL(I+NX+1,3)=NN+NX+1+I
    CONDU(I+NX+1,3)=CONDLB
    CONDU(NX+NX+I,1)=CONDRB
59  NREL(NX+NX+I,1)=I+NN+4X+NY+1
63  NREL(I,3)=NN+NX+1
    NREL(NX,1)=NN+NX+NY+1
    NREL(NN-NX+1,3)=NN+NX+NY
    NREL(NN,1)=TNN-NX
    CONDU(I,3)=CONDLB
    CONDU(NX,1)=CONDRB
    CONDU(NN-NX+1,3)=CONDLB
    CONDU(NN,1)=CONDRB
    READ(IRD,60) (RX(I),I=1,NX)
    READ(IRD,60) (RY(I),I=1,NY)
60  FORMAT(16F5.2)
    IJ=0
    IJ1=0
    DO 42 I=1,NN
    IJ=IJ+1
    IF(IJ,LE,NX) GO TO 6
    IJ1=IJ1+1
    IJ=1
6  J=I-IJ1-NX
    CO(I,1)=RX(J)
42  CO(I,2)=RY(IJ1+1)
    DO 61 I=NU,N3
    J=I-NN
    CO(I+2*NY+NX,2)=COBBY
    CO(I,2)=COTBY
    CO(I,1)=RX(J)
61  CO(I+2*NY+NX,1)=RX(J)

```

```

DO 62 I=N4,N5
J=I-NN=NX
CO(I+NY,1)=CORBX
CO(I,1)=COLBX
CO(I,2)=RY(J)
62 CO(I+NY,2)=RY(J)
DO 18 K=1,NN
J2=NSIDE(K)
DUM=0.0
DO 35 J=1,J2
JJ=JJ+1
NS(1)=NREL(K,J)
IF(J-1,EQ,0) NS(2)=NREL(K,J2)
IF(J-1,NE,0) NS(2)=NREL(K,J-1)
IF(J,EQ,J2) NS(3)=NREL(K,1)
IF(J,NE,J2) NS(3)=NREL(K,J+1)
DO 36 I=1,3
X=CO(K,1)-CO(NS(I),1)
Y=CO(K,2)-CO(NS(I),2)
36 PERM(I)=X*X+Y*Y
DO 37 I=2,3
X=CO(NS(I),1)-CO(NS(I),1)
Y=CO(NS(I),2)-CO(NS(I),2)
37 PERM(I+2)=X*X+Y*Y
A=PERM(1)
B=(ABS(PERM(4)+PERM(2)-PERM(1)))**2,
C=(ABS(PERM(3)+PERM(5)-PERM(1)))**2,
D=4*PERM(4)*PERM(2)
E=4*PERM(3)*PERM(5)
WIDTH=SQRT((0.25*A*B)/(D-B))+SQRT((0.25*A*C)/(E-C))
LENGTH=SQRT(A)
IF(JJ,GT,TNN) WRITE(IPR,16) K,NS(1),CONDU(K,J),WIDTH,LENGTH
IF(JJ,LE,TNN) WRITE(IPR,16) K,NS(1),CONDU(K,J),WIDTH,LENGTH,JJ,CO(
1JJ,1),CO(JJ,2)
16 FORMAT(I5,4H AND,I4,10X,F5,2,2F10,2,10X,I5,11X,F9,2,9X,F9,2)
IF(LSW1,EG,1) CONDU(K,J)=(CONDU(K,J))*(WIDTH/LENGTH)*DMTIM/1000000,
IF(LSW1,EG,2) CONDU(K,J)=CONDU(K,J)*(WIDTH/LENGTH)*DMTIM
DUM=DUM+WIDTH*LENGTH
35 CONTINUE
IF(LSW1,EG,1) AREA(K)=DUM*.25*(SCALE/1000000)**2,
IF(LSW1,EG,2) AREA(K)=DUM*.25*(SCALE/100)**2,
18 TAREA=TAREA+AREA(K)
DO 38 K=1,NN
38 AS(K)=AREA(K)*STO
IF(NSCONF,EG,0) GO TO 54
READ(IR,52) PCONC,STUCON
52 FORMAT(F8,4,F7,5)
54 IF(NCONF,EG,0) GO TO 57
READ(IR,55) THID
55 FORMAT(F4,0)
DO 56 K=1,NCONF
56 CO(K,2)=THID
57 WRITE(IPR,19)
19 FORMAT(/5H NODE,5X,4HAREA,5X,14HSTORAGE COEFF.,6X,7HSURFACE,7X,8H
1BOTYOM,9X,9HTHICKNESS,7X,9HTHICKNESS,5X,12HPERMEABILITY,5X,14HSTOR
2AGE COEFF.,/22X,7HAQUIFER,9X,9HELEVATION,5X,9HELEVATION,5X,13HCONF,
3AQUIFER,6X,8HTOPLAYER,7X,8HTOPLAYER,10X,8HTOPLAYER/)
DUM=0.0
DO 58 K=1,NN
DL=SL(K)-BL(K)-CO(K,2)

```



```

IF(K.LE,NSCONF) WRITE(IPR,20) K,AREA(K),STO,SL(K),BL(K),CO(K,2),OL
1,PCONC,STOCON
IF(K.GT,NSCONF,AND,K.LE,NCONF) WRITE(IPR,20) K,AREA(K),STO,SL(K),P
IL(K),CO(K,2)
IF(K.GT,NCONF) WRITE(IPR,20) K,AREA(K),STO,SL(K),BL(K)
20  FORMAT(I3,F11.2,F14.5,F17.0,F13.0,2F16.0,F16.3,F18.3)
50  CONTINUE
WRITE(IPR,33) TAREA
33  FORMAT(/F14.2)
IF(NSCONF.EQ.0) GO TO 43
00 53 K=1,NSCONF
PCONF(K)=PCONC*DMTIM
53  ASC(K)=STOCON*AREA(K)
43  IF(LSW2.EQ.2) GO TO 23
WRITE(IPR,21)
21  FORMAT(/5H NODE,5X,12HUPPER LIMITS,5X,12HLOWER LIMITS//)
WRITE(IPR,22) (K,UL(K),OL(K),K=1,NN)
22  FORMAT(I3,F16.2,F17.2)
23  WRITE (IPR,24)
24  FORMAT(/4X,23HMISCELLANEOUS CONSTANTS,10X,27HVALUES OF EXTERNAL S
1WITCHES/)
WRITE (IPR,25)LIST,LSW1
25  FORMAT(6X,7HLIST = ,I7,26X,7HLSW1 = ,I2)
WRITE(IPR,31) MAJOR,LSW2
31  FORMAT(5X,8HMAJOR = ,I7,26X,7HLSW2 = ,I2)
WRITE(IPR,32) MINOR
32  FORMAT(5X,8HMINOR = ,I7)
WRITE (IPR,27)SCALE
27  FORMAT(5X,8HSCALE = ,F10.2)
WRITE (IPR,28) COEFFA
28  FORMAT(4X,9HCOEFFA = ,F10.2)
WRITE(IPR,14) DMTIM
14  FORMAT(5X,8HDMTIM = ,F10.2)
WRITE (IPR,26)DELTA
26  FORMAT(5X,8HDELTA = ,F14.6)
WRITE (IPR,29)ERROR
29  FORMAT(5X,8HERROR = ,F14.6)
WRITE(IPR,30)DELQ
30  FORMAT(6X,7HDELQ = ,F14.6)
WRITE(IDSK1) DELQ,COEFFA,T,NN,NO,TNN,ERROR,DELTA,NCONF,LSW1
WRITE(IDSK1) TITLE,TMRAS,(BL(K),K=1,TNN),LIST,MAJOR,MINOR,NCONF
WRITE(IDSK1) (UL(K),OL(K),SL(K),AREA(K),AS(K),NSIDE(K),K=1,NN)
WRITE(IDSK1) ((NREL(K,J),CONDU(K,J),J=1,7),K=1,NN)
IF(NCONF.GT.0) WRITE(IDSK1) (CO(I,2),I=1,NCONF)
IF(NSCONF.GT.0) WRITE(IDSK1) (ASC(K),PCONF(K),K=1,NCONF)
END

```

```

C  GROUNDWATERMODEL/PART2 : CALCULATION OF GROUNDWATER FLOW(ELIMINATION)
  INTEGER TNN,SUBITR
  REAL IMP
  DIMENSION NREL( NN,7),NSIDE( NN),AREA( NN),TITLE(40),TMBAS(2)
  DIMENSION RECH( NN),FLWCON( NN),TOTALQ( NN),S( NN),QSEEP( NN)
  DIMENSION CONDU( NN,7),PCONF( NN),AS( NN),H(TNN),HCONF( NN)
  DIMENSION BL(TNN),THID( NN),A( NN, NN+1),SL( NN)

C
  IRD=0
  IPR=5
  IDSK1=1
  IDSK2=2
  REMIND IDSK1
  READ(IDSK1) DELO,COEFFA,T,NN,NO,TNN,ERROR,DELTA,NCONF,LSW1
  READ(IDSK1) TITLE,TMBAS,(BL(K),K=1,TNN),LIST,MAJOR,MINOR,NSCONF
  READ(IDSK1) (DUM,DUM,DUM,AREA(K),AS(K),NSIDE(K),K=1,NN)
  READ(IDSK1) ((NREL(K,J),CONDU(K,J),J=1,7),K=1,NN)
  IF(NCONF.GT.0) READ(IDSK1) (THID(I),I=1,NCONF)
  IF(NSCONF.GT.0) READ(IDSK1) (DUM,PCONF(K),K=1,NSCONF)
  READ(IRD,9) LSW3,LSW4,LSW5
9  FORMAT(3I4)
  READ(IRD,10) (H(K),K=1,TNN)
  IF(NSCONF.GT.0) READ(IRD,10) (HCONF(K),K=1,NSCONF)
18  FORMAT(10F8,2)
  WRITE(IDSK2) LIST,MAJOR,MINOR,DELTA,T,NN,TNN,LSW1
  WRITE(IDSK2) (H(K),K=1,TNN),NSCONF,(SL(K),K=1,NN),NCONF,TITLE,TMBAS
  IF(NSCONF.GT.0) WRITE(IDSK2) (HCONF(K),K=1,NSCONF)
  WRITE(IPR,46)
46  FORMAT(12H CALCULATION////)
  WRITE(IPR,47) TITLE
47  FORMAT(21H GROUNDWATERMODEL FOR,20A4/20A4)
  WRITE(IPR,48)
48  FORMAT(///2BH VALUES OF EXTERNAL SWITCHES/)
  WRITE(IPR,49) LSW3,LSW4,LSW5
49  FORMAT(10X,7HLSW3 = ,I2/10X,7HLSW4 = ,I2/10X,7HLSW5 = ,I2)
  WRITE(IPR,30)
30  FORMAT(1H1)
  DO 90 L=1,LIST
  IF(LSW3.NE.1) GO TO 31
  READ(IRD,1) (RECH(K),K=1,NN)
  FORMAT(8X,14F5,3)
1  READ(IRD,2) (FLWCON(K),K=1,NN)
  FORMAT(8X,7F10,4)
  DO 32 K=1,NN
32  RECH(K)=RECH(K)+AREA(K)
  READ(IRD,4) (H(K),K=NO,TNN)
  FORMAT(8X,9F8,2)
  DO 80 M=1,MAJOR
31  IF(LSW4.EQ.1.AND.L.NE.1) GO TO 5
  IF(LSW3.NE.2) GO TO 5
  READ(IRD,1) (RECH(K),K=1,NN)
  READ(IRD,2) (FLWCON(K),K=1,NN)
  DO 3 K=1,NN
 3  RECH(K)=RECH(K)+AREA(K)
  READ(IRD,4) (H(K),K=NO,TNN)
  DO 70 JT = 1,MINOR
 5  IF(LSW3.NE.3) GO TO 7
  READ(IRD,1) (RECH(K),K=1,NN)
  READ(IRD,2) (FLWCON(K),K=1,NN)
  DO 6 K=1,NN

```

```

6 RECH(K)=RECH(K)+AREA(K)
  READ(IRD,4) (H(K),K=NO,TNN)
7 IF(LSW5,EG,2) READ(IRD,20) DELTA
28 FORMAT(F6,4)
  T = T + DELTA
  ITRNO = 0
  DO 8 K=1,NN
  DO 39 LT=1,NO
39 A(K,LT)=0.0
  8 CONTINUE
  DO 35 K=1,NSCONF
35 QSEEP(K)=0.0
  DO 14 K=1,NN
  J2=NSIDE(K)
  DO 13 J=1,J2
  NOD=NREL(K,J)
  B=(BL(NOD)+BL(K))/2.
  HA=(H(NOD)+H(K))/2.
  THI=HA+B
  IF(K,LE,NSCONF,AND,NOD,LE,NSCONF) THI=(THID(K)+THID(NOD))*0.5
  IF(K,LE,NSCONF) THI=THID(K)
  IF(NOD,LE,NSCONF) THI=THID(NOD)
  Y=THI*CONDU(K,J)
  IF(NOD,LE,NN) A(K,NOD)=A(K,NOD)+Y
  IF(NOD,GT,NN) A(K,NO)=A(K,NO)-Y*H(NOD)
  A(K,K)=A(K,K)-Y
13 CONTINUE
  IF(K,GT,NSCONF) GO TO 33
  DL=BL(K)+THID(K)
  C=(HCONF(K)-DL)/PCONF(K)
  A(K,K)=A(K,K)-AS(K)/DELTA=AREA(K)/C
  A(K,NO)=A(K,NO)-FL*CON(K)=(AS(K)/DELTA)*H(K)+(AREA(K)/C)*HCONF(K)
  GO TO 14
33 IF(K,LE,NSCONF) RECH(K)=0.0
  A(K,K)=A(K,K)-AS(K)/DELTA
  A(K,NO)=A(K,NO)-RECH(K)-FL*CON(K)=(AS(K)/DELTA)*H(K)
14 CONTINUE
  DO 40 K=1,NN
  KP1=K+1
  DO 41 J=KP1,NO
41 A(K,J)=A(K,J)/A(K,K)
  A(K,K)=1.0
  DO 40 I=1,NN
  IF(I,EQ,K,OR,A(I,K),EQ,0.0) GO TO 40
42 DO 42 J=KP1,NO
  A(I,J)=A(I,J)-A(I,K)*A(K,J)
  A(I,K)=0.0
40 CONTINUE
  DO 15 K=1,NN
  S(K)=(H(K)-A(K,NO))*AS(K)/DELTA
15 IF(K,LE,NSCONF) QSEEP(K)=(HCONF(K)-A(K,NO))/C)*AREA(K)
  H(K)=A(K,NO)
  DO 45 K=1,NN
  TOTALQ(K)=0.0
  J2=NSIDE(K)
  DO 36 J=1,J2
  NOD=NREL(K,J)
  B=(BL(NOD)+BL(K))/2.
  HA=(H(NOD)+H(K))/2.
  THI=HA+B

```

```

IF(K.LE.NCONF.AND.NOD.LE.NCONF) TH1=(THID(K)+THID(NOD))*0.5
IF(K.LE.NCONF) TH1=THID(K)
IF(NOD.LE.NCONF) TH1=THID(NOD)
Y=TH1*CONDU(K,J)
Q=Y*(H(NOD)-H(K))
36 TOTALQ(K)=TOTALQ(K)+Q
45 CONTINUE
DUM=0.0
WRITE(10SK2) (RECH(K),TOTALQ(K),S(K),FLNCON(K),DUM,K=1,NN)
WRITE(10SK2) (H(K),K=1,TNN),T,ITRNO,DELTA,SUBITR
IF(NSCONF.GT.0) WRITE(10SK2) (HCONF(K),QSEEP(K),SUM,K=1,NSCONF)
DO 26 K=1,NN
IF(K.GT.NCONF) GO TO 26
IF(H(K).LT.(BL(K)+THID(K))) WRITE(IPR,25) K,T
25 FORMAT(/42H PIEZOMETRIC LEVEL IN MAIN AQUIFER AT NODE,I3,26H IS B
1ELOW TOPLAYER AT TIME,FB,4)
26 CONTINUE
70 CONTINUE
80 CONTINUE
90 CONTINUE
END

```

APPENDIX 2

DATA FORMATS

A computer card contains 80 columns in which input data can be punched. To ensure that the punched data are read correctly by the computer, certain specifications must be prescribed. These specifications indicate how many columns are allocated to each variable and what kind of data can be expected. This information is provided by a FORMAT statement.

We have used three types of FORMAT statements in our programs: I, F, and A formats.

1. I format, in the form *Iw*. I specifies that the value is a decimal integer value (whole number); *w* specifies the field length (number of columns) in which the value can be punched. The value is punched as far right as possible in the allotted group of columns; unused space is left blank. The use of a plus sign is optional; if no plus sign is punched, the value is taken to be positive. Blanks after the last punched digit in each field are interpreted as zeros. Decimal points should not be punched.

Examples of I formats are shown below.

Format	External value	Card columns							Value stored in computer memory	
		1	2	3	4	5	6	7		
I3	284		2	8	4				+284	
I4	-284		-	2	8	4			-284	
I5	174				1	7	4		+174	
I7	29.4					2	9	.	4	not permitted
I5	10					1			+ 10	

2. F format, in the form $Fw.d$. F specifies that the value has a fractional part; w specifies the field length in which the value can be punched; d indicates the number of columns allocated after the decimal point. With an F format no decimal point is punched because d prescribes where the decimal point is placed when such a value is stored in the computer memory. If the decimal point is punched, it overrides d . As with the I format, the use of a plus sign is optional, leading blanks are ignored, and blanks after the last digit are interpreted as zeros. Examples of F formats are shown below.

Format	External value	Card columns								Value stored in computer memory
		1	2	3	4	5	6	7	8	
F8.5	2.35472		2	3	5	4	7	2		+2.35472
F5.2	-0.78		-	7	8					-0.78
F8.3	24.0			2	4					+24.000
F6.3	4.75		4	.	7	5				+4.750

3. A format in the form Aw . A specifies that the value contains alphanumeric (besides digits, also characters A-Z); this format is used to print headings and explanations along with output data; w specifies the field length in which the value can be punched. Examples of A formats are shown below.

Format	External value	Card columns				Value stored in computer memory
		1	2	3	4	
A2	cm	c	m			cm
A4	cm		c	m		cm
A4	data	d	a	t	a	data

In general, more values than just one will be punched on a card. Data are entered into the computer memory by the execution of a READ statement in the source program. This statement lists the names of the variables for which certain values are to be read from a card. A read statement can also read the values of an array, which is a collection of variables of one specific type. Values must be punched on the card in the same sequence as the variable names are listed in the READ statement. The computer then

follows a scanning process: the first value on the card corresponds with the first variable name, the second value with the second variable name, and so on, for as many variable names as there are.

The scanning proceeds from left to right and begins with the first (most left) data value on the card. The execution of a new READ statement *always* initiates the reading of a new card.

If more variable names have the same format, one can place a repetitive number (multiplier digit) before the actual format. So, 5I4 means that five succeeding variable names have the same format: I4. This is valid for all three types of formats.

Two other signs will be encountered in the format statements. The first is the sign /; it indicates that more than 80 columns have been allocated to punch the necessary information and that the remaining information can be found on the following card. If 80 columns or less are used, the following card must be a blank. The second sign is the character x preceded by a digit; it means that in certain columns no information is to be expected; for example, 8x in a format statement will skip the reading of 8 columns.

Examples

Card 6 of Data Set I (Chap. 4 Sect. 2.1) initiates the reading of a new card in the card deck; four values must be punched on that card, corresponding to the variable names of DELTA, MINOR, MAJOR, and LIST. If DELTA = 0.50, MINOR = 4, MAJOR = 3, LIST = 2, and the corresponding format is F4.2, 3I4, the value for DELTA must be punched according to format F4.2 and the values of MINOR, MAJOR and LIST according to format I4. The punched card is then as follows:

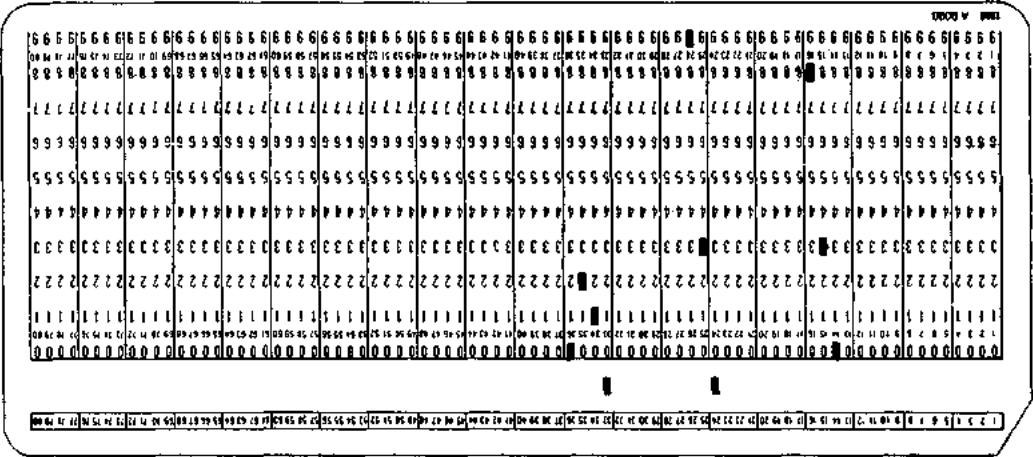

Card 5 of DATA SET II (Chap. 4 Sect. 2.2) initiates the reading of a new card in the card deck. If NN = 3, three values must be punched on that card, corresponding to the variable names of FLWCON(1), FLWCON(2), and FLWCON(3). If FLWCON(1) = -0.38, FLWCON(2) = -0.39, FLWCON(3) = -1.20, and the corresponding format is 8x, F10.4, the punched card is as follows:

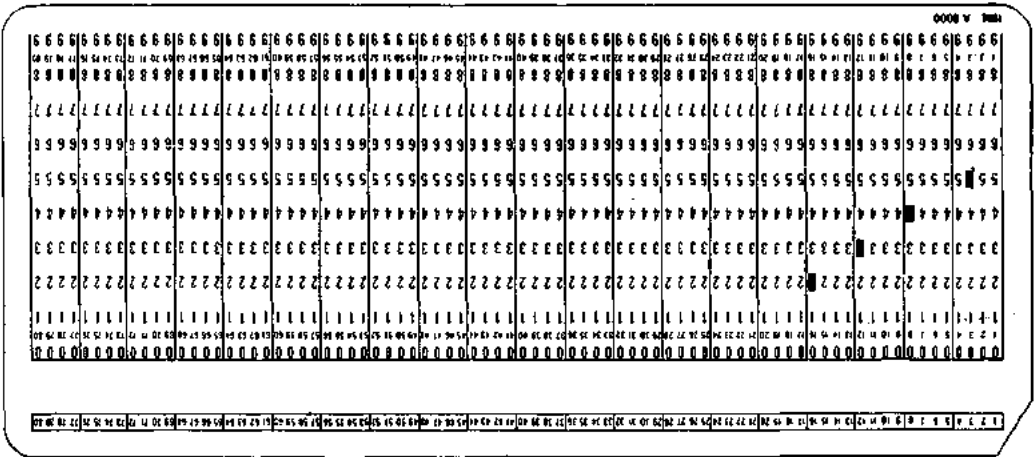

APPENDIX 3

SEPARATION OF THE COMPONENTS OF THE NET RECHARGE

In the standard groundwater model package, the net recharge is divided into two categories: external flows measured or calculated as a depth per time and external flows measured or calculated as a volume per time. To each category, we have allocated one variable: RECH(K) to the first and FLWCON(K) to the second. The values of these variables represent the algebraic sum of a number of external flows, which is calculated manually and entered in the computer. This procedure is followed to keep the calculation program's memory requirements within certain limits and of the same order of magnitude as those of the other programs.

In calibrating the model or in making production runs, it may happen that one wants to change the values of one or more of the external flow components. For example, in certain nodal areas one may wish to change the abstraction rates of pumped wells by 20 per cent; one cannot then simply change the lumped variable FLWCON(K) by 20 per cent. As explained in Chap. 6, the procedure to be followed to obtain the new nodal FLWCON(K) values is to calculate by hand the new abstraction rates of the nodal areas in question and add to them the external flows that have remained unchanged.

These tedious hand calculations can be avoided by letting the computer do the job. To do so, one allocates separate variables to each of the external flows and makes the following adjustments in SGMP2 or OPRO2, depending on which program package one is using:

- In the dimension statements, add the names of the new variables;

- In the READ statements, add the reading of these new variables and remove from the READ statements the reading of RECH(K) and FLWCON(K).
- After the new READ statements, add two statements in which the new variables are lumped together in either RECH(K) or FLWCON(K) or in both. This is done to avoid having to make more adjustments than would otherwise be necessary.

Because the boundary conditions can be read on three different time levels depending on the value of LSW3, these adjustments must be made three times.

To illustrate the adjustments, let us assume a model study in which the following external flows occur:

- recharge by rainfall
- percolation of irrigation water from the field
- percolation of irrigation water from the main and branch canals
- abstractions by wells
- subsurface flow across flow-controlled boundaries.

The data of the first two external flows, which are available as a depth per time, are denoted arbitrarily as R1(K) and R2(K), respectively. The data of the other three external flows, which are available as a volume per time, are denoted arbitrarily as P1(K), P2(K), and P3(K) respectively. These separate variables must be added to the listing of SGMP2 or OPR02, part of which is presented below. An asterisk means that a new card must be added and a minus sign means that an existing card must be removed; a broken line indicates that a jump has been made in the listing (see also Appendix 1).

C GROUNDWATERMODEL/PART2 : CALCULATION OF GROUNDWATER FLOW(GAUSS/SEIDEL)

INTEGER TNN,SUBITR

REAL IMP

DIMENSION NREL(NN,7),NSIDE(NN),AREA(NN),TITLE(40),TMBAS(2)

DIMENSION H(TNN),HO(NN),HCONF(NN),HOCONF(NN),DRECH(NN)

DIMENSION RECH(NN),FLWCON(NN),TOTALQ(NN),S(NN),QSEEP(NN)

DIMENSION CONDU(NN,7),PCONF(NN),SC(NN),ASC(NN),AS(NN)

DIMENSION BL(TNN),UL(NN),OL(NN),THID(NN),SL(NN)

DIMENSION R1(NN),R2(NN),P1(NN),P2(NN),P3(NN)

C

```
IRD=8
IPR=5
  ⋮
DO 90 L=1,LIST
IF(LSW3.NE.1) GO TO 31
READ(IRD,1) (R1(K),K=1,NN) *
READ(IRD,1) (R2(K),K=1,NN) *
READ(IRD,1) (RECH(K),K=1,NN) -
1  FORMAT(8x,14F5.3)
READ(IRD,2) (P1(K),K=1,NN) *
READ(IRD,2) (P2(K),K=1,NN) *
READ(IRD,2) (P3(K),K=1,NN) *
READ(IRD,2) (FLWCON(K),K=1,NN) -
2  FORMAT(8x,7F10.4)
DO 32 K=1,NN
RECH(K)=R1(K)+R2(K) *
FLWCON(K)=P1(K)+P2(K)+P3(K) *
32 RECH(K)=RECH(K)*AREA(K)
READ(IRD,4) (H(K),K=NO,TNN)
4  FORMAT(8x,9F8.2)
31 DO 80 M=1,MAJOR
IF(LSW4.EQ.1.AND.L.NE.1) GO TO 5
IF(LSW3.NE.2) GO TO 5
READ(IRD,1) (R1(K),K=1,NN) *
READ(IRD,1) (R2(K),K=1,NN) *
READ(IRD,1) (RECH(K),K=1,NN) -
READ(IRD,2) (P1(K),K=1,NN) *
READ(IRD,2) (P2(K),K=1,NN) *
READ(IRD,2) (P3(K),K=1,NN) *
READ(IRD,2) (FLWCON(K),K=1,NN) -
DO 3 K=1,NN
RECH(K)=R1(K)+R2(K) *
FLWCON(K)=P1(K)+P2(K)+P3(K) *
3  RECH(K)=RECH(K)*AREA(K)
READ(IRD,4) (H(K),K=NO,TNN)
```

```

5   DO 70 JT=1,MINOR
      IF(LSW3.NE.3) GO TO 7
      READ(IRD,1) (R1(K),K=1,NN)
      READ(IRD,1) (R2(K),K=1,NN)
      READ(IRD,1) (RECH(K),K=1,NN)
      READ(IRD,2) (P1(K),K=1,NN)
      READ(IRD,2) (P2(K),K=1,NN)
      READ(IRD,2) (P3(K),K=1,NN)
      READ(IRD,2) (FLWCON(K),K=1,NN)
      DO 6 K=1,NN
          RECH(K)=R1(K)+R2(K)
          FLWCON(K)=P1(K)+P2(K)+P3(K)
6   RECH(K)=RECH(K)*AREA(K)
      READ(IRD,4) (H(K),K=NO,TNN)
7   IF(LSW5.EQ.2) READ(IRD,28) DELTA
28  FORMAT(F6.4)
      T=T+DELTA

```

Because the external flows are lumped together in the calculation program, either in RECH(K) or FLWCON(K) or in both, the print-out of the results will only show the lumped values. If one wishes to have a print-out of the separate values, a listing of Data Set II must be made.

REFERENCES

- ATHAVALE, R.N., C.S. MURTY, and R. CHAUD, 1980. Estimation of recharge to the phreatic aquifers of the lower Maner Basin, India, by using the tritium injection method. *J. of Hydrol.* 45:185-202.
- BOUWER, H., 1978. *Groundwater Hydrology*. McGraw-Hill, New York, 480 p.
- BOUWER, H. and R.C. RICE, 1976. A slug test for determining hydraulic conductivity of unconfined aquifers with completely or partially penetrating wells. *Water Resour. Res.* 12:423-428.
- BRUGGEMAN, G.A., 1976. *Nieuwe ontwikkelingen op het gebied van pompproeven. Cursus Porositeit en permeabiliteit*. Stichting Postakademiale Vorming Gezondheidstechniek, Delft.
- COOPER, H.H., J.D. BREDEHOEFT, and I.S. PAPADOPULOS, 1967. Response of a finite diameter well to an instantaneous charge of water. *Water Resour. Res.*, 3(1):263-269.
- DAVIS, S.N. and R.J.M. de WIEST, 1966. *Hydrogeology*. John Wiley & Sons, New York, 463 p.
- DIETRICH, G. and I.M. Goodwill, 1972. *Groundwater model of the Mires basin*. Working Document 32, UNDP/FAO, Iraklion, 27 p.
- DOORENBOS, J. and W.O. PRUITT, 1977. *Guidelines for prediction of crop water requirements*. FAO Irrig. Drain. Pap. 24, Rome, 144 p.
- EDELMAN, J.H., 1947. *Over de berekening van grondwaterstromingen*. Thesis. Univ. of Technol., Delft (mimeographed).
- EDELMAN, J.H., 1972. *Groundwater hydraulics of extensive aquifers*. Bull. 13, ILRI, Wageningen, 216 p.

- ERNST, L.F., N.A. de RIDDER, and J.J. de Vries, 1970. A geohydrologic study of East Gelderland (Netherlands). *Geol. en Mijnbouw*, 49(6):457-488.
- FEDDES, R.A., 1971. Water, heat and crop growth. Thesis Univ. of Agric., Wageningen, 184 p.
- FERRIS, J.G., D.B. KNOWLES, R.H. BROWN, and R.W. STALLMAN, 1962. Theory of aquifer tests. U.S. Geol. Survey Water Supply Pap. 1536-E.
- GRAY, D.M. and J.M. WIGHAM, 1970. Runoff-rainfall-general. In: Handbook on the principles of hydrology. D.M. Gray (ed.), Can. Natl. Comm. Int. Hydrol. Decade, Ottawa, p. 7.1-7.24.
- GUN, J.A.M. van der, 1979. Schatting van de elastische bergingscoefficient van zandige watervoerende pakketten. Annual Report 1979. Dienst Grondwaterverkenning TNO, Delft, p. 5-61.
- HILLEL, D., 1971. Soil and Water, Physical principles and processes. Acad. Press, New York, 288 p.
- HUISMAN, L., 1972. Groundwater recovery. Winchester, New York, 366 p.
- ISAACSON, E. and H.B. KELLER, 1966. Analysis of numerical methods. John Wiley & Sons, New York, 541 p.
- KAMP, G.S.J.P. van der, 1973. Periodic flow of groundwater. Rodopi, Amsterdam, 121 p.
- KRUSEMAN, G.P. and N.A. de RIDDER, 1979. Analysis and evaluation of pumping test data. Bull. 11, ILRI, Wageningen, 200 p.
- MCCRACKEN, D.D. and W.S. DORN, 1964. Numerical methods and fortran programming. John Wiley & Sons, New York, 457 p.
- MOLEN, W.H. van der, 1971. Lecture notes Agrohydrology. Univ. of Agric., Wageningen.
- MORRIS, D.A. and A.J. JOHNSON, 1967. Summary of hydrologic and physical properties of rock and soil material as analyzed by the Hydrol. Lab. of the U.S. Geol. Survey, 1948-1960. U.S. Geol. Survey Water Supply Pap. 1839-D.
- RALSTON, A. and H.S. WILF, 1967. Mathematical methods for digital computers (Vol. I). John Wiley & Sons, New York, 291 p.
- READING, H.G., 1978 (ed.). Sedimentary environments and facies. Blackwell Sci. Publ., Oxford, 557 p.
- REMSON, I., G.M. HORNBERGER and F.J. MOLZ, 1971. Numerical methods in subsurface hydrology; with an introduction to the finite element method, Wiley-Interscience, New York, 389 p.

- RICHTMEYER, R.D. and K.W. MORTON, 1967. Difference methods for initial-value problems. John Wiley & Sons, New York, 405 p.
- RIDDER, N.A. de, and K.E. WIT, 1965. A comparative study of the hydraulic conductivity of unconsolidated sediments. J. of Hydrol. 3:180-206.
- RIDDER, N.A. de, and A. EREZ, 1977. Optimum use of water resources. Publ. 21, ILRI, Wageningen, 250 p.
- RIJTEMA, P.E., 1965. An analysis of actual evapotranspiration. Agric. Res. Rep. 689, Pudoc, Wageningen, 107 p.
- RUSHTON, K.R. and S.C. REDSHAW, 1979. Seepage and groundwater flow. John Wiley & Sons, New York, 339 p.
- STALLMAN, R.W., 1962. Constant head, nonsteady state, no recharge. In: Theory of aquifer tests, Ferris et al., Geol. Survey Water Supply Pap. 1536-E, Washington, p. 126-131.
- TALSMA, T., 1963. The control of saline groundwater. Thesis Univ. of Agric., Wageningen, 68 p.
- THOMAS, R.G., 1973. Groundwater models. Irrig. Drain. Pap. 21, FAO, Rome, 192 p.
- THORNBURY, W.D., 1969. Principles of geomorphology, John Wiley & Sons, New York, 594 p.
- TODD, D.K., 1980. Groundwater hydrology, 2nd edition. John Wiley & Sons, New York, 535 p.
- TYSON, H.N. and E.M. WEBER, 1963. Use of electronic computers in the simulation of the dynamic behaviour of groundwater basins. Water Resour. Eng. Conf., Am. Soc. Civ. Eng., May 13-17, Milwaukee, Wis.
- UFFINK, G.J.M., 1979. De bepaling van K-waarden in het veld aan de hand van 'putproeven' en 'puntproeven'. Mededeling 79-2. Rijksinst. voor Drinkwatervoorziening, Voorburg (Den Haag), 61 p.
- WESSELING, J., 1959. Transmission of tidal waves in elastic artesian basins. Neth. J. Agric. Science, 7:22-32.
- WESSELING, J., 1973. Seepage. In: Drainage Principles and Applications. Publ. 16, Vol. II, ILRI, Wageningen, p. 189-222.
- WIND, G.P., 1955. A field experiment concerning capillary rise of moisture in a heavy clay soil. Neth. J. Agric. Science, 3:60-69.

SUBJECT INDEX

Adaptations to computer system	129	Array, adjustments	124, 129
Alluvial fan	26	definition	128
recharge	26	dimensions	129
Aquifer, bottom elevation	92, 110	Boundaries, arbitrary	29
boundaries	22	curved	86, 88
characteristics	32	external	22, 26
confined	17	flow-controlled	26
definition	17	head-controlled	25
facies changes	30	impermeable	22
hydraulic conductivity	35	internal	22, 26
isopach map	19, 93	recharge	26
lateral extent	19	zero-flow	22
multi	17	Boundary conditions	22, 114, 146
recharge	52	changing	182
sand percentage	30	sensitivity analysis	185
saturated thickness	93	Calibration, of model	169
schematization	16	period	170
semi-confined	17	procedure	176
test	32	Capillary rise	62
thickness	17, 91, 93, 110	different soils	63
types	16	Central memory	129
unconfined	17	Classification, sandy	
		materials	37
		net recharge	97

Confining layer	16	Hydraulic conductivity	35
bottom elevation	94	confining layer	109
constant watertable	115	grain size method	38
hydraulic conductivity	109	map	45, 91
saturated thickness	94	network	91
specific yield	46, 79, 96	Hydrological equilibrium	1
variable watertable	115	stress	8, 48
Conservation of mass	76	unit	86
Darcy's law	76	Impermeable base	17, 24, 92
Data set	99	depth	24
Depositional area	11	structural map	19
environment of	12, 13, 14	Iterations, maximum number	112
Discharge of aquifers	59	Iteration technique	82
methods of estimating	59	Gauss-Seidel	82
Discharge areas	12, 59	Karstified limestone	17
Discretization, space	79, 84	Laminar flow	17
time	80, 81, 105	Line printer	121
Double precision	130	plot scale	124
Elimination technique	82	Logical device number	129
Gauss-Jordan	83	Matrix, coefficient	83
Error dimension	107	notation	83
estimation	108	Mini-computer	124
selection	107	Model, calibration	6, 96, 169
sources	171, 177	conceptual	7
tolerable	82	features	75
Evapotranspiration	62	numerical	7
potential	64	restrictions	75
External flows	97	Morphological features	12
categories	97	Net recharge of aquifer	97
Finite difference method	3, 79	variables	115
Format	209	Network, nodal	80
Groundwater balance	67	coordinate system	90
equation	67	design	84
unknown terms	70	examples	90
Groundwater basin	12	graded	87
		irregular	89

layout	104	semi-confined aquifer	78
modification	186	unconfined aquifer	77
regular	86	Source program	99
scale	104	Source term	76
Nodal area	79	confined aquifer	77
net recharge	97	semi-confined aquifer	78
specific yield	95, 109	unconfined aquifer	77
storage coefficient	96, 109	Specific yield	45, 77
surface elevation	95, 110	determination	45
Nodes	79	estimation	46
arbitrary	89	order of magnitude	46
coordinates	90, 104	of nodal area	95, 109
eccentric	96	Standard deviation	123
external	89, 104	calculation	123
internal	89, 104	Storage coefficient	47, 77, 95
number	85, 104	estimation	47
numbering	126	of nodal area	96, 109
Non-linear features	2, 75	Stratigraphic correlation	14
Non-water-bearing layer	16	unit	30
Peripheral device	129	Structural deformation	14, 16
Physical framework	8	Time, step	81, 104, 105
Production run	181	period	105
Program card	130	Transmissivity	32
Recharge of aquifers	55	map	45
methods of estimating	55	methods of estimating	32, 33, 35
Recharge areas	12		36, 42
confined aquifers	52	Turbulent flow	17
unconfined aquifers	53	Unsaturated zone, water balance	68
Residual term	81, 107	Water-bearing formation	16
Scratch files	131	Watertable, calculation	93
Semipermeable layer	16	contour map	50, 86
Sensitivity analysis	177, 185	correction	51
Simulation period	182	elevation	49
Sink term	76	error in node	123
confined aquifer	77	frequency of measuring	50

historical	50, 96
initial	50, 96, 115
nodal area	96
observation network	49
prescribed limits	110

AUTHOR INDEX

- Athavale, R.N. 58
Bouwer, H. 33
Bredehoeft, J.D. 33
Brown, R.H. 33
Bruggeman, G.A. 35
Chaud, R. 58
Cooper, H.H. 33
Davis, S.N. 12
Dietrich, G. 75
Doorenbos, J. 62, 63
Dorn, W.S. 83
Edelman, J.H. 44
Erez, A. 184
Ernst, L.F. 54
Ferris, J.G. 33
Goodwill, I.M. 75
Gray, D.M. 56
Gun, J.A.M. van der 47, 48
Hornberger, G.M. 86
Huisman, L. 44
Isaacson, E. 84
Johnson, A.J. 46
Kamp, G.S.J.P. van der 43
Keller, H.B. 84
Knowles, D.B. 33
Kruseman, G.P. 24, 32, 33
McCracken, D.D. 83
Molen, W.H. van der 64
Molz, F.J. 86
Morris, D.A. 46
Morton, K.W. 81
Murty, C.S. 58
Papadopulos, I.S. 33
Pruitt, W.O. 62, 63
Ralston, A. 82
Reading, H.G. 12, 30
Redshaw, S.C. 85, 89, 170
Remson, I. 86
Rice, R.C. 33
Richtmeyer, R.D. 81
Ridder, N.A. de 24, 32, 33, 38, 43,
54, 184
Rushton, K.R. 85, 89, 170
Stallman, R.W. 33, 44
Thomas, R.G. 82, 85, 90
Thornbury, W.D. 12

fodd, D.K. 12, 43
Tyson, H.N. 75
Uffink, G.J.M. 36
Vries, J.J. de 54
Weber, E.M. 75
Wesseling, J. 43, 44
Wiest, R.J.M. de 12
Wigham, J.M. 56
Wilf, H.S. 82
Wit, K.E. 38, 43